

Connecting a T5 Series FMS or Colibri Tank Monitor to and Allied SSC ANDI box

Overview

This document explains how to connect a T5 Series Fuel Management System or Colibri Tank Monitor to an Allied Electronics Station Site Controller (SSC) ANDI box and allow the ANDI box to receive inventory information from the T5 Series tank monitor. In applications where dispenser reconciliation is desired, it will also allow the Allied ANDI box to send sales information to the T5 Series, without the need for a TS-DIMIB (Dispenser Interface Module).

Installation

A cable must be created to accomplish the interface. A shielded cable is recommended with at least three conductors. There will need to be a DB9-male connector on the T5 Series end and a DB25M connector on channel 13 of the ANDI box.

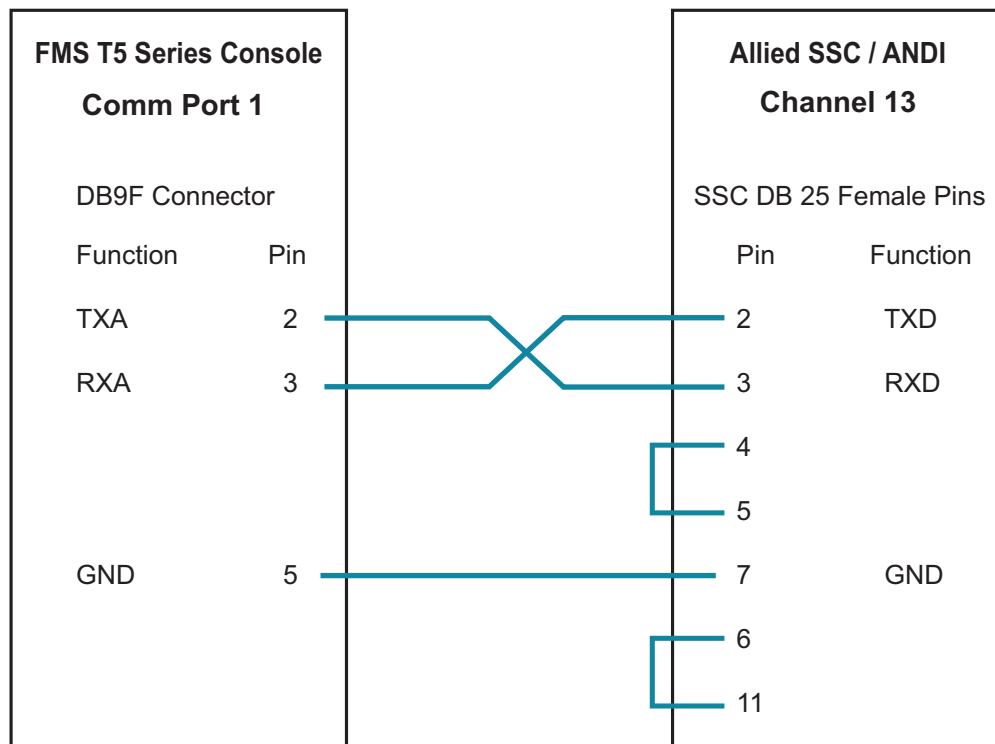

TECHNICAL BULLETIN

January 22, 2013 • TB0113-11

Programming

The T5 Series Comm port 1 needs to be programmed to the following parameters:

TS5/TS550/TS5000/Colibri

System/Configuration/Comm 1

COMM 1	
Mode	Veeder-Root
Baud Rate	9600
Data Bits	7
Parity	Odd
Stop Bits	1

TS550 evo

Setup/Parameters/Communications/Serial Ports/Comm 1

Communications		
Serial Ports		
COMM 1		
	Mode	Veeder-Root
	Baud Rate	9600
	Data Bits	7
	Parity	Odd
	Stop Bits	1

Testing

To check the connection from the ANDI box to the T5 Series, press "D" on the SSC keyboard.

CH-13 Link Up
TLS RS-232 FP

When the SSC detects that it is connected to the TS Series, the device name changes to TLS-R

CH-13 Link Up
TLS-R RS-232 FP