



XP Installation Guide Overview

Manual #	Revision	Date	Changes from Previous Revision
771-232-00	9	May 2015	Added information about secondary test boot test tubes

Preface

Franklin Fueling Systems (FFS) manufactures XP series piping systems, which are designed to provide containment and transfer of product in your fueling system. XP series piping can be used in either pressure or suction applications.

XP series piping systems are installed in accordance with published FFS installation instructions by factory certified installers only. FFS cannot guarantee against leakage if the installation process is not followed properly or if the maintenance program is not adhered to. To ensure your system integrity, it is essential that an inspection program be in place and adhered to as outlined in our warranty. Refer to this installation guide, individual installation instructions, the APT product catalog, or visit the APT website at www.flexpipe.com for proper product and installation practices for your site design. If you need further assistance, contact FFS or an FFS sales representative immediately to ensure a proper system design and installation.

Important Reference Items

- All XP series flexible piping systems are UL 971 approved (File # MH17457) for use with A&M Fuels, CT Fuels, HB Fuels, and MV Fuels.
- XP series piping systems are for underground use only with the rated operating pressures and bend radii given in this document. XP series piping is not intended for use as connector pipe or with aboveground or marine applications.
- XP series piping systems are for use in normal soil applications.
- Sumps should be monitored to be kept free of debris and spilled product at all times; please refer to the XP Warranty for further details.

XP Piping Information Table

Direct Bury (D)	Primary Pipe Rating (psi)	Secondary Pipe Rating (psi)	Minimum Bend Radius
XP-100-D	100 (6.89 bar)	N/A	36" (92cm)
XP-150-D	100 (6.89 bar)	N/A	36" (92 cm)
XP-175-D	100 (6.89 bar)	N/A	36" (92 cm)
XP-200-D	100 (6.89 bar)	N/A	36" (92 cm)
XP-200-D	100 (6.89 bar)	N/A	36" (92 cm)
XP-100-SC	100 (6.89 bar)	8 (0.55 bar)	36" (92 cm)
XP-150-SC	100 (6.89 bar)	50 (3.45 bar)	36" (92 cm)
XP-175-SC	100 (6.89 bar)	8 (0.55 bar)	36" (92 cm)
XP-200-SC	100 (6.89 bar)	8 (0.55 bar)	36" (92 cm)

Definitions & Acronyms

XP series piping with a SC suffix in the part number indicates that the piping is designed to be used as a PS, NV, or a VR system. XP series piping with a D suffix in the part number indicates that the piping is designed to be used as a PC, NV, or a VR system.

Aviation & Marine Fuels (A&M Fuels) - Motor vehicle and speciality aviation or marine use fuels for up to 100% kerosene or leaded gasoline.

Concentrated Fuels (CT Fuels) - Motor vehicle and alternate unblended fuels for up to 100% concentrations of Toluene, Methanol and Ethanol.

High Blend Fuels (HB Fuels) - Motor vehicle fuels with higher than normal gasoline blends with a maximum of 50% Methanol or 50% Ethanol.

Integral Primary/Secondary (PS) - A single pipe and/or fitting constructed at the manufacturer that combines both primary carrier and secondary containment with an interstitial space that can be monitored for leakage.

Motor Vehicle Fuels (MV Fuels) - Petroleum-based hydrocarbon fuel typically found in consumer dispensing stations, such as gasoline or diesel, including blended fuels with a maximum of 15% MTBE, 15% Methanol or 30% Ethanol.

Normal Vent (NV) - Pipe and/or fittings intended to transfer displaced air or fuel vapors from an underground tank to grade during filling and provide atmospheric pressure equalization.

Primary Carrier (PC) - Pipe and/or fittings intended for continuous contact with the flammable liquids in a system under normal use conditions.

Underground Nonmetallic (UGN)

Vapor Recovery (VR) - Pipe and/or fittings intended to transfer collected air and fuel vapors in a pressure vacuum system to an underground tank during dispensing.

Contacting FFS

Please feel free to contact us at:

Franklin Fueling Systems
3760 Marsh Road Madison, WI 53718 USA
Tel: +1 608 838 8786
Fax: +1 608 838 6433
Tel: USA & Canada 1 800 225 9787
Tel: Mexico 001 800 738 7610

Franklin Fueling Systems GmbH
Rudolf-Diesel-Strasse 20
54516 Wittlich, Germany
Tel: +49 6571 105 380
Fax: +49 6571 105 510

www.franklinfueling.com

Safety

This guide is a system installation overview, and should be used in conjunction with part-specific installation instructions. Refer to the installation documentation for the equipment described in this guide and any other related equipment for complete installation and safety information. To ensure your system integrity, it is essential that you follow all applicable installation instructions and federal, state, and local codes.



Warning XP fittings must be installed in conjunction with XP piping. Using P-series clamshell fittings with XP pipe will result in improper assembly and potential fitting failure.

Preparation & Materials

Inspection of Materials

FFS handles all XP series piping system components with care; however, rough handling (drops and impacts) may cause damage/leaks during storage or transit. Examine all piping for punctures, deep cuts, kinking or any other visible damage. Do not use any component of the XP series piping system that shows signs of damage. If any questions arise in regards to potential damage, please contact FFS immediately.

Storing Materials

APT piping primary and secondary jackets should not be exposed to direct sunlight. APT pipe is delivered on reels with a protective wrap which inhibits UV damage to the pipe during shipping. APT Secondary Contained (SC) pipe incorporates a scuff guard layer which protects the pipe in transit and adds a degree of UV protection to the pipe jackets. FFS recommends that the scuff guard layer not be exposed to direct sunlight for longer than three months or UV degradation may occur. It is the contractor's responsibility to cover entry boots installed above grade with a UV resistant cover or lid in order to eliminate UV exposure.

Keep sump lids and sump bases together, do not mix parts; number the lids and bases to avoid confusion. Do not store lids separate from sump bases for long periods of time. Install tank sump lids completely when work is not being performed inside sumps (especially during backfilling).

Installation Temperature Range

APT's flexible piping construction can be installed at a maximum recommended temperature of 135° F (57° C). Below 25° F (-4° C), APT flexible piping may become difficult to work with. When working with APT flexible piping below 25° F (-4° C), avoid pipe kinking or impacting because this may create damage to the primary and/or secondary layers. When working with APT flexible piping in cold temperatures, the pipe may stiffen which may increase the potential to kink the pipe during installation. Below 25° F (-4° C), the minimum bend radii may have to be increased to prevent kinking.

Trenches

Trenches should be dug straight when possible. If changes in direction are required, trench corners should be cut at 45° angles to allow for the piping run's proper bend radius. There must be a minimum of 6" (15.24 cm) of space between the outside of a piping run and a trench wall. The minimum allowable pipe bend radius for all XP series piping is 36" (92 cm).

Important: If a section of pipe is kinked, do not use that section of pipe.

Backfill Materials

Clean, compacted sand, pea gravel, or 1/8 to 3/4" (3.2 to 19 mm) or smaller crushed rock (without sharp edges) should be used as backfill material. There must be a minimum of 4" (10.16 cm) of approved backfill material under, and between, piping runs. Backfill material must not be contaminated with any petroleum product or other contaminant and must meet the requirements published in APT's warranty.

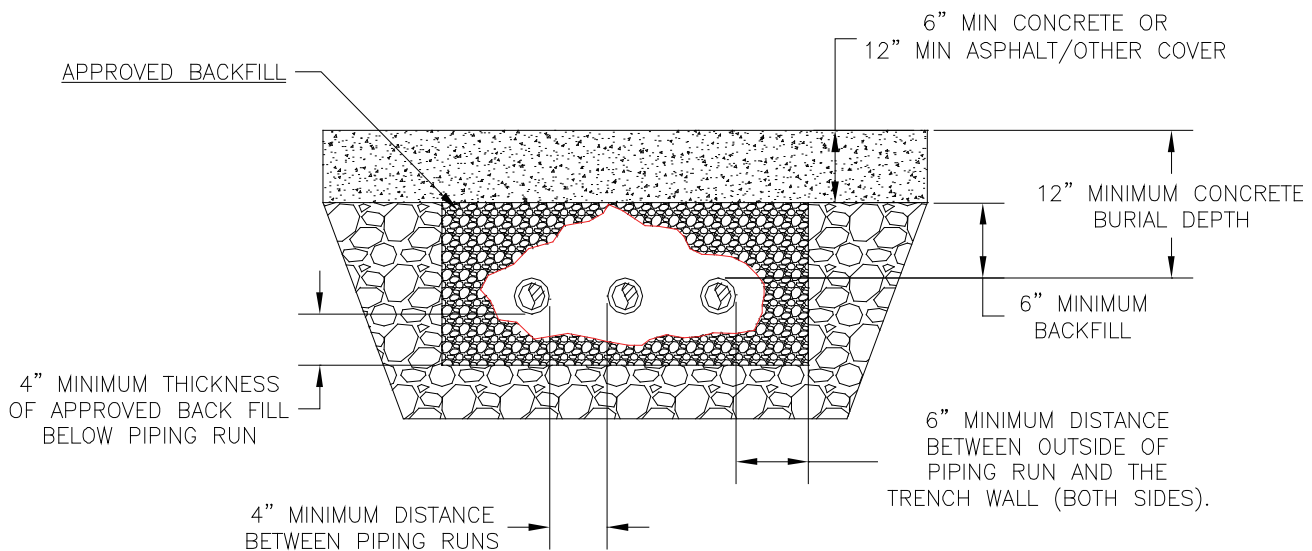

Figure 1: XP Pipe Installation Cross Section

Spacing Requirements (Crossovers)

Avoid pipe crosses, but, if they are unavoidable, try to keep them close to, but not over, the tanks. Always maintain a minimum of 4" (10.16 cm) of backfill material under, and between, the piping runs. The backfill above the highest crossover pipe and each side of the piping must be a minimum of 6" (15.24 cm).

XP Burial Depths

In installations with traffic meeting AASHTO H20 wheel loading requirements, the pipe must be buried at least 12" (30.48 cm) deep with a minimum of 6" (15.24 cm) of backfill above the pipe and 6" (15.24 cm) of concrete above the backfill. For installations using asphalt or other burial material, the pipe must be buried at least 18" (45.72 cm) deep with a minimum of 6" (15.24 cm) of backfill above the pipe and 12" (30.48 cm) of asphalt and/or other burial material above the backfill.

XP Piping Slopes

Product piping should slope back to the tank field at a minimum of 1/8" per foot (10.42 mm per meter).

Installation

Sump Cutdown

APT tank sumps come in a variety of models, but all sumps can be cut down in 3" (7.62 cm) increments to adjust to different burial depths and layouts. After cutting the sump, de-burr and sand the cut edge to create a proper sealing surface.

Sump Lids/Manholes

APT transition sumps, intermediate piping sumps, and one piece tank sumps all have a factory installed nitrile gasket to maintain a watertight seal between the sump and the cover. Ensure proper manhole installation to facilitate proper tank sump lid operation. Center the manhole skirt around the sump riser and lid - there should be a 1" (2.54 cm) minimum clearance between the bottom of the manhole lid and the top of the sump lid. In addition, there should be a minimum 1" (2.54 cm) clearance around the sides of the sump.

The manhole skirt should extend below the tank sump lid to ensure proper operation of the sump lid and to keep backfill and debris from the lid sealing area. When installing a sump, make sure to leave the lid on during the backfill process to help prevent the sump from distorting. Pour a minimum of four inches of concrete around the manhole skirt.

Sump Mounting (TFAs)

APT tank fitting adapters (TFA's) attach the bottom of the sump to the 4" or 6" bung at the storage tank and seal on the outside of the sump using a nitrile gasket. When applying a uniform bead of urethane sealant to the top side of the TFA's nitrile gasket, FFS recommends using Bostik 1100 (or equivalent). **Do not remove the TFA ring gasket - it is permanently adhered to the fitting and removing it could cause the seal to fail.**

Pipe Pulling

When dispensing pipe from a reel, always pull it from the bottom of the reel or the pipe may become kinked. If the pipe becomes kinked when taking it off of the reel, do not use the kinked section of pipe. When approaching the end of a reel of pipe, disconnect both ends of the pipe from the reel to avoid kinking.

Fittings

FFS requires that OEM fittings be used in all XP series piping systems. FFS offers a variety of options for XP series pipe fittings each with its own unique installation instructions. Each XP series fitting package will have detailed installation instructions specific to that design to ensure a proper, leak-tight assembly.

Fittings that have NPT threads should be sealed with a gas and oil resistant pipe sealant. When completing the installation of a clamshell fitting, tighten the clamps so that they are metal to metal. Swage fitting installations must be done using only APT swage fitting tooling. Using other manufacturer's tooling will result in improper assembly and potential fitting failure.

FFS offers galvanized pipe connectors to prevent corrosion. Pipe connectors can be purchased locally as long as they are 150 lb malleable, standard with NPT threads.

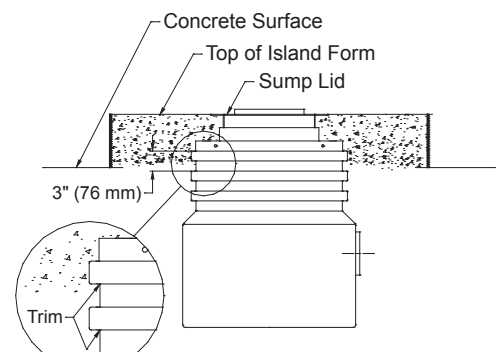
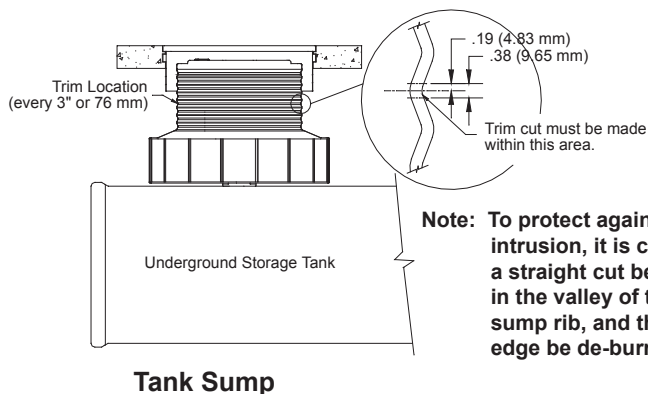

Figure 2: Sump Preparation

Boots

Entry boots come in sizes made to accommodate all pipe sizes including conduit and rigid pipe from ½" to 4" (13 mm to 10.16 cm). When installing pipe into entry boots, piping must not be more than 15 degrees from perpendicular to the sump walls. Entry angles in excess of 15 degrees from perpendicular can cause excessive stress, which may damage entry boots, kink pipe and/or cause environmental contamination. Entry boots should also not be installed in the bottom of any containment sump.

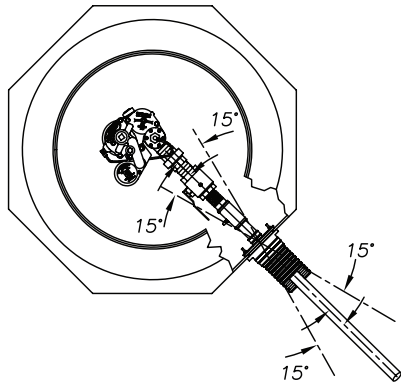

Figure 3: Turbine Sump

Note: Pipe must enter a sump at an angle less than 15° to eliminate strain on entry boots. Piping and fittings must be in-line with the mating.

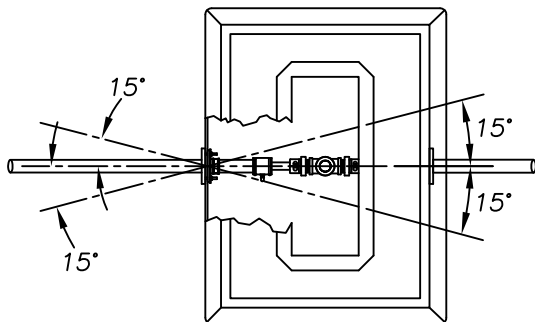

Figure 4: Dispenser Sump

Ducting

Ducting is available as a piping chase, which allows for pipe removal after installation. APT ducting is not a containment layer, but it is air-testable. Refer to document# 771-205-00 for Duct Installation.

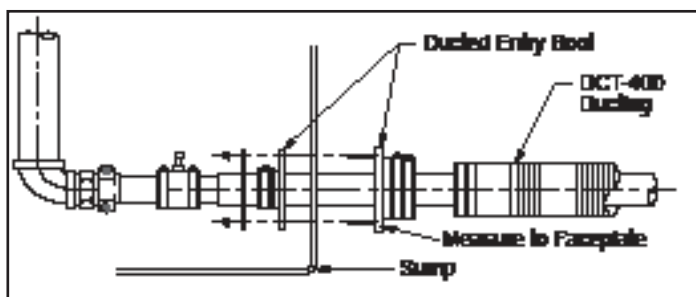

Figure 5: Duct Installation

1. Pull the ducting and cut it to the length measured from faceplate to faceplate of the entry boots. Set it on the entry boots at this time.
2. Run a measuring tape/line through the duct, pull it tight and measure the distance from the Pipe Termination Collars.

Pipe Termination Collar

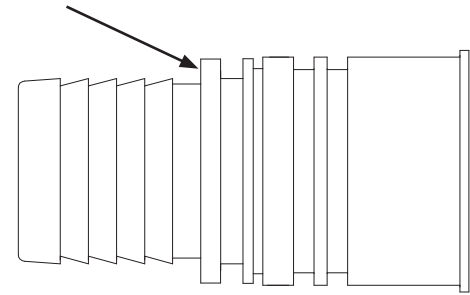

Figure 3: Pipe Termination Collar Location

CAUTION: Do NOT cut the pipe longer than required. Excess pipe inside of ducting can cause pipe movement due to line shock.

3. Cut the pipe to the measurement from step 1.
4. Remove the duct from the entry boots.
5. Extend the pipe through the ducting.

Note: Attach a rounded object to the end of the pipe to keep it from catching on the ducting ribs as it moves through.

6. Push the pipe through the entry boots.
7. If the necessary fitting connections or test boots have not already been installed, then do so now.
8. Attach the piping to the fitting.

Pipe Cutback

Once the pipe run is pulled and each section is cut to length, square off the end of the pipe, de-burr it, and then proceed with the cutback. If you are using SC (Secondary Contained) piping, cut back the scuff guard layer even with or outside of the sump wall and cut back the SC layer 4½" (11.5 cm). For further cutback details, see the process's complete description in the *DWC-XP-XXX Double Wall Cutter (SC) Installation Instructions*.

Pipe Layers

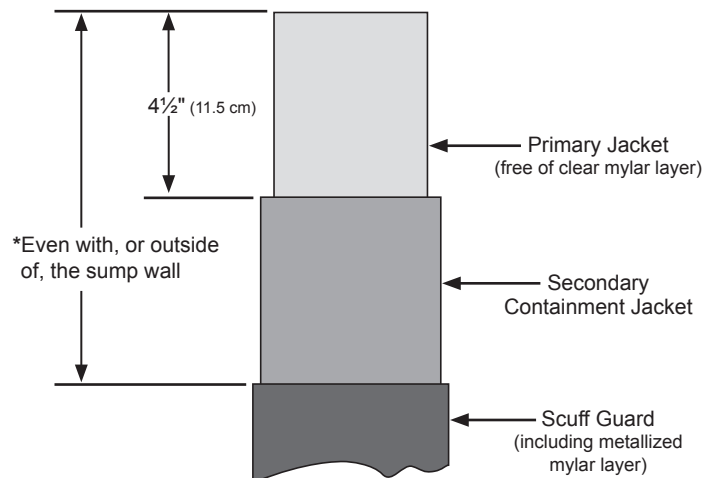

* The scuff guard must be cut back to be even with, or outside of, the sump wall ensuring that the entry boot seals on the SC jacket and not on the scuff guard layer.

Testing

All federal, state and local codes and governmental requirements for inspecting, testing, monitoring, and maintaining the system and property on which APT products are installed must be followed at all times. Refer to local codes for required pressures, test durations, and all other applicable codes. Test regulator kits and bypass tubes are available. Entry boots have Schrader (tire) valve hardware for simple, standard connections.

Note: If using FFS APT STK-1 or STK-2 Secondary Test Boot Kits, the test boots can remain in place without being moved back. Follow the installation and use instructions for those kits.

After completing testing, relieve pressure from all elements of the piping system. The APT secondary test boot can be installed with the test tube removed or left in place.

Removing test tubes from dispenser/turbine sump:

- After the secondary pipe testing has been completed, remove the test tube (BPT-200).
- Loosen the clamps from around the test boot and (STB) and slide the test boot towards the XP fitting so the secondary is open and available for visual inspection.

Leaving test tubes in place in the dispenser sump:

- After the secondary pipe testing has been completed on site, loosen the clamps from around the test boot (STB) in the **turbine sump only** and slide the test boot towards the XP fitting so the secondary is open and available for visual inspection. Leave the test tubes and test boots in place and tight in the dispenser sumps.

Note: Please refer to the Franklin Fueling Systems Warranty documentation for additional details on the requirements for monitoring the containment sumps.

Operating Maximum

Primary pipe is CLU US listed for a 100 PSI (6.89 bar) maximum operating pressure.

Installation Testing

Primary Minimum/Maximum Test Pressure

Apply an air source to the XP piping. Pressurize the line to between 50 and 100 psi (3.45 and 6.89 bar) and allow the pressure to settle. After piping is pressurized, soap all joints and fittings. If a leak in the termination fitting is discovered relieve the air pressure, retighten, and repressurize. The duration of the test may vary, check with the local authority or inspector to verify requirements. If no local requirements are specified, APT recommends a minimum of a 1 hour pressure test should be observed with no pressure loss. Upon completion of a passing pressure test, pressure can be relieved or pressure may be held until backfill and concrete is poured.

Note: If pressure is left on the piping system for an extended period of time, thermal expansion or contraction may cause the piping pressure to fluctuate.

Secondary Piping Test Pressure

It is critical to verify that the scuff guard has been properly cut back outside of the containment sump so that the test boot seals to the outside of the ribbed secondary layer for this pressure test. If the test boots is not sealed directly onto the ribbed secondary layer, you could get false readings.

Once the test boots are in place, pressurize the piping to between 5 and 8 PSI (0.34 and 0.55 bar). After the pressure has stabilized, disconnect the air supply and monitor the system for leakage. The line needs to remain pressurized for a minimum of one hour with no pressure loss detected in order for the piping to pass.

More detailed instructions on to how to perform this test can be found in our *TRK-200 Test Regulator Kit Installation Instructions* (document# 771-115-00).

Note: XP-150-SC piping is UL listed for up to 50 PSI for use in closed system monitoring.

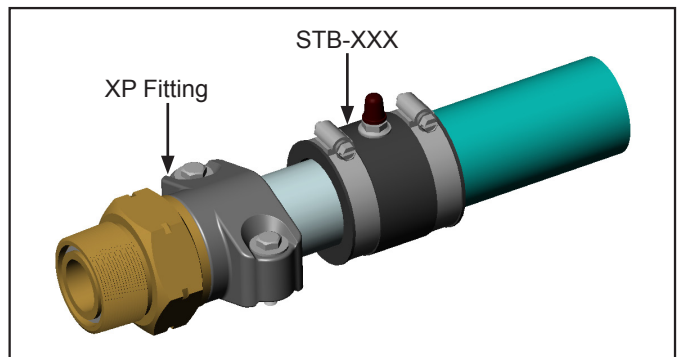

Clamshell SC Test Configuration

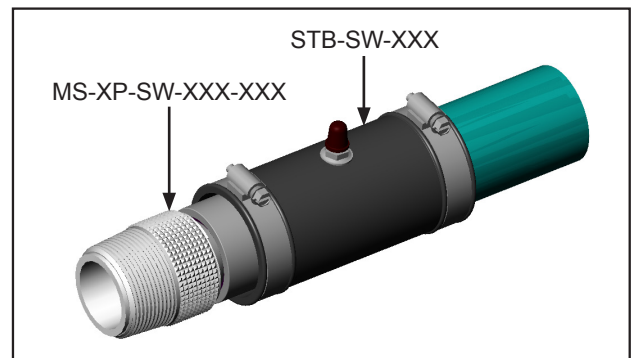

Swage SC Test Configuration

Note: "XP only" is etched on the collar of MS-XP-SW series fittings.

Ducting Test Pressure

Once the test boots are in place, pressurize the ducting to between 2 and 4 PSI (0.14 and 0.28 bar). After the pressure has stabilized, disconnect the air supply and monitor the system for leakage. The line needs to remain pressurized for 30 minutes with no pressure loss detected for the ducting to pass.

More detailed instructions on to how to perform this test can be found in our *TRK-200 Test Regulator Kit Installation Instructions* (document# 771-115-00).

Sumps

Hydrostatically testing sumps is required to ensure that all sump penetrations are tight. Fill the sump with a water-based test solution so that every penetration into the sump is below the water line. FFS offers two methods to hydrostatically test an APT sump:

- TS-STC Sump Test System – This system measures level changes up to .002" (.05 mm) and will automatically pass or fail a sump in 15 minutes if the level drops more than the leak limit during the test.
- Manual measurement – Place a mark at the current water line after filling above all of the penetration fittings. Cover the sump so that no fluid can enter or evaporate out its top. Leave the sump for 1 hour and verify that water line has not moved. If the water line has not dropped below the mark in 1 hour, the sump has passed.

Monthly/Annual/Semi-Annual Testing

Primary Minimum/Maximum Test Pressure

FFS does not require that piping be pressure tested for warranty compliance after the installation testing procedures above have been passed. However, in some cases, there are federal, state, and/or local pressure testing schedules that must be followed.

For pressure tests, it is recommended that XP series primary carrier piping be tested at a minimum of 50 PSI (3.45 bar). FFS recommends not exceeding 100 PSI (6.89 bar) on the primary carrier piping.

Secondary Test Pressure

FFS does not require pressure testing of the secondary containment layer for warranty compliance after the installation testing above has passed. However, in some cases, there are federal, state, and/or local pressure testing schedules that must be followed. For pressure tests, it is recommended that the XP series open system secondary containment be tested to between 5 and 8 PSI (0.34 and 0.55 bar) for a minimum of one hour with no pressure loss. APT piping is an "open system" unless otherwise required by local code or as part of a continuously monitored secondary system.

Ducting Test Pressure

FFS does not require pressure testing of the ducting for warranty compliance after the installation testing above has passed. However, in some cases there are federal, state, and/or local pressure testing schedules that must be followed. For pressure tests, it is recommended that ducting be tested to between 2 and 4 PSI (0.14 and 0.28 bar) for a minimum of 30 minutes with no pressure loss.

Sumps

FFS has no requirement for hydrostatically testing sumps after installation; however a detailed monitoring program is required to stay in compliance with the warranty conditions. Please see the Inspections section under the Records header in this document for more information on sump maintenance.

Records

Checklist

The *Installation Checklist and Warranty Start-Up Form* (F-8388) must be properly completed, signed by the APT factory certified installer and an authorized representative of the Purchaser/End User, and returned to FFS no later than sixty (60) days after the installation of the APT product for which a warranty claim is being made.

The *Sump Inspection Register* form or an EPA recommended/required check list form must be properly completed. This checklist must be kept on-site where the APT products are installed, and made available for FFS's inspection and copying upon request.

Inspections

Liquid sensors must be properly installed in each containment sump located on the property at which APT products are installed, *or* monthly visual inspections of all tank and dispenser sumps must be performed. Monthly visual inspections must be logged on *Sump Inspection Register* or an EPA recommended/required check list form at the time they are performed.

Inspections should include, but are not limited to, the following points:

- Looking for evidence of infiltration since the last inspection
- Checking for liquids or staining (new staining)
- Looking for excessive dirt/debris and corrosion
- Ensuring that lids are properly sealed
- Examining sumps for structural damage
- Verifying the condition of boots, piping, and other equipment

Sump sensors, if installed, must be tested annually and these test results logged on *Sump Inspection Register* immediately after they are performed. Any leaks detected by liquid sensors, inspections or other observations must be immediately corrected. Any leaks that are detected but not acted upon immediately to correct are considered negligence on the part of the Purchaser/End User and will void FFS's obligation under our warranty.

Submersible pumping systems that use electronic or mechanical line leak detection equipment must be properly installed, operated, and maintained in proper working order on the property at which APT products are installed at all times after APT products are first installed on the property.

Repairs

Sumps and the pipe's secondary jacket are spill containers, not storage vessels, for product and/or water. If leakage or damage is detected in any part of the system (either by inspection of the sump, a leak detector, or similar monitors), the problems are to be immediately investigated by the site operator. If leakage or damage to the piping system is verified, the manufacturer must be notified. Disabling or ignoring any of the previously mentioned leak detection methods may lead to further damage, could create a potentially deadly hazard, and will release FFS from any obligation under our warranty.

Clean up spilled liquids and remove vapors immediately. Clean out filters and remove gas rags from sumps immediately after maintenance. Extended exposure to gas and/or vapors can degrade system integrity (clean up within 72 hours recommended). If a component within your APT system comes into question, please immediately contact FFS or your local FFS sales representative. When you contact us, please provide: photos and/or a detailed visual inspection, a copy of the installation and startup information, and a copy of the *Sump Inspection Register*.

Written notice of any claim under our warranty must be given to FFS at the following address promptly after discovery of the circumstances giving rise to such claim:

Franklin Fueling Systems Inc.
3760 Marsh Road
Madison, WI 53718, U.S.A.

FFS shall have no obligation under our warranty if any of these conditions are not met.

Certification

All APT products must only be installed by APT factory certified installers and in accordance with published FFS installation instructions. All individuals installing APT products will be certified through a home study certification test. Although FFS or a representative may perform onsite or classroom training sessions, a passing grade of 10% or fewer missed questions is required for installer certification on APT products. Upon receipt of a certification packet from FFS, the individual seeking certification should review the packet materials, complete the enclosed certification test, and return the completed test and certification information to FFS. Upon receipt of a test with a passing grade, FFS will certify the individual as an installer of APT products. The certified individual will receive notification from FFS confirming acceptance as an installer of APT products. The individual will be certified for a period of two years after the date of acceptance as a certified installer. At the end of the two year period, all individuals will be required to recertify via another passing home study certification test. FFS reserves the right to change the certification packet, home study test, or any element of this process as required to ensure proper installer certification and/or recertification. As this process changes, FFS will work with individuals submitting for certification or recertification to older revisions to ensure that installers are properly trained. If you have any questions, please contact FFS for more information.



Franklin Fueling Systems

www.franklinfueling.com

3760 Marsh Road • Madison, WI 53718, U.S.A.

Tel: +1 608 838 8786 • Fax: +1 608 838 6433

Tel: USA & Canada 1 800 225 9787 • Tel: México 001 800 738 7610

Franklin Fueling Systems GmbH

Rudolf-Diesel-Strasse 20 • 54516 Wittlich, GERMANY

Tel: +49-6571-105-380 • Fax: +49-6571-105-510