

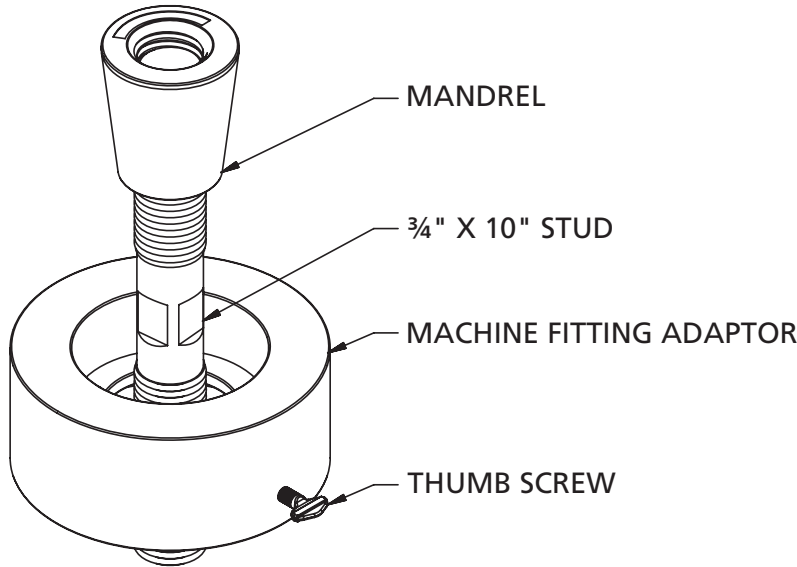

Swage Machine

The swage machine is used for installation of APT swage fittings. Competitive machines can be used provided they are modified with an APT swage kit. The machine is electrically driven, using the stainless steel fitting installed at the end of APT flex pipe. Each machine comes with the required mandrels and collars to swage all pipe sizes from 1 1/2" through 2".



SWAGE KIT

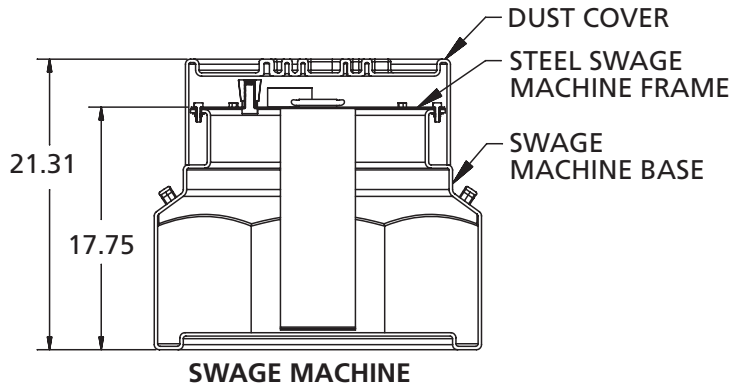
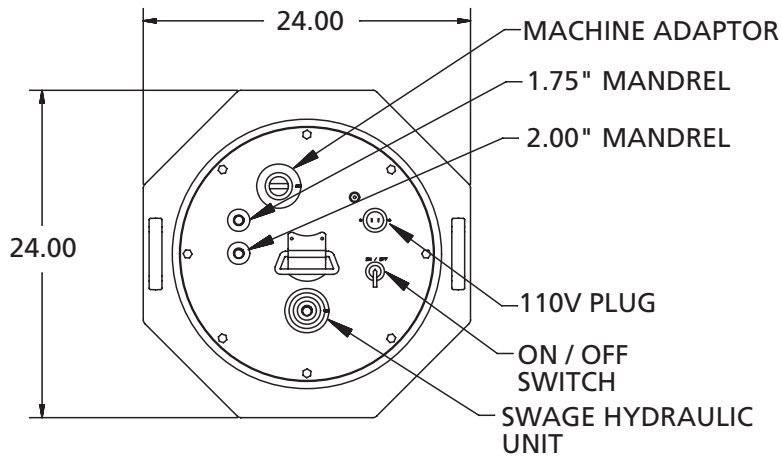

SWAGE MACHINE

Design Highlights & Advantages

- 110 volt standard.
- Includes all required components to swage 1 1/2", 1 3/4" and 2" fittings.
- Easy to use detailed operating instructions for hassle free assembly of swage fittings.
- Durable construction, capable of withstanding harsh field environments.
- Wide stable base construction.
- Swage kits available separately.

MODEL	DESCRIPTION
SMB-100	Swage Machine
SWK-150	Swage Tool Kit 1.50"
SWK-175	Swage Tool Kit 1.75"
SWK-200	Swage Tool Kit 2.00"

