



Defender Series™
Spill Containment



Franklin Fueling Systems

Defender Series™



The Best Defense

The Defender Series spill container combines years of knowledge and experience in forecourts across the globe to represent the next generation in spill containment. The Defender Series adapts alongside evolving environmental regulations with the latest innovations in spill containment. Get the best defense and quality construction with the Defender Series from Franklin Fueling systems.

Key Features	Defender Series	Competitor 1	Competitor 2
Gasket face seal to riser	✓	-	-
3" of variable height installation	✓	-	-
Installs on 16" centers	✓	-	✓
Upgradable from single wall to double wall	✓	✓	-
Protected plow ring bolts	✓	-	-
Flexibility without the use of bellows	✓	-	-

Fugitive Emission Protection

Proactively protecting a site from the dangers of fugitive emissions can save station owners both time and money by avoiding remediation due to fuel leakage. The Defender Series provides several key defenses from these costly expenses:

- Single or double wall models available
- Compression gasket provides a vapor tight mechanical seal
- Drop tube compression adapter ensures a vapor tight seal
- Drain valve designed to meet CARB leak rate requirements
- Concentrated secondary containment catch basin provides immediate notification of integrity breach

Integrity Confirmation

Always know how your spill containment is performing and get immediate confirmation on the integrity of the interstitial space with the following Defender Series features:

- I² (Interstitial Integrity) Monitor facilitates efficient monthly and annual visual inspections confirming the integrity of the secondary containment space
- Electronic liquid detection sensor option available with proven ULS sensor for active leak detection
- ULS wiring penetrates side wall of gravel guard ensuring no additional installation height requirement
- ULS wiring utilizes an IP 68 rated Buna cable gland ensure a tight seal

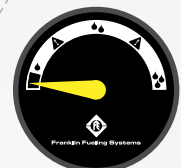

Franklin Fueling Systems

Spill Containment

Easy Installation and Maintenance

Maximize your business' value and minimize installation and maintenance expenses with features like:

- Field replaceable containment – replace easily without having to break concrete, simply loosen the four plow ring bolts to remove and replace interior containment.
- Plow rings bolts are protected – located inside the interior of the container, shielding them from the potential wear and tear of the forecourt environment.
- Variable height adjustments – allows for an installation height between 14 1/2" and 17 5/8" , for easy installation in retrofit applications.

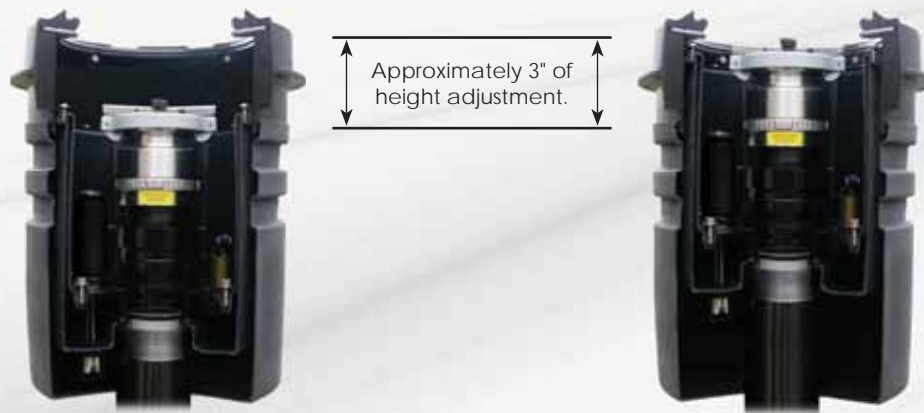

Double Wall Upgradeability

Designed with the future in mind. Protect your investment by choosing a spill container that is able to evolve as regulations change with a simple upgrade process:

- Loosen the four interior snow plow ring bolts and remove the ring.
- Unthread the single wall container.
- Thread the double wall containment back onto the existing tank riser and replace the snow plow ring.

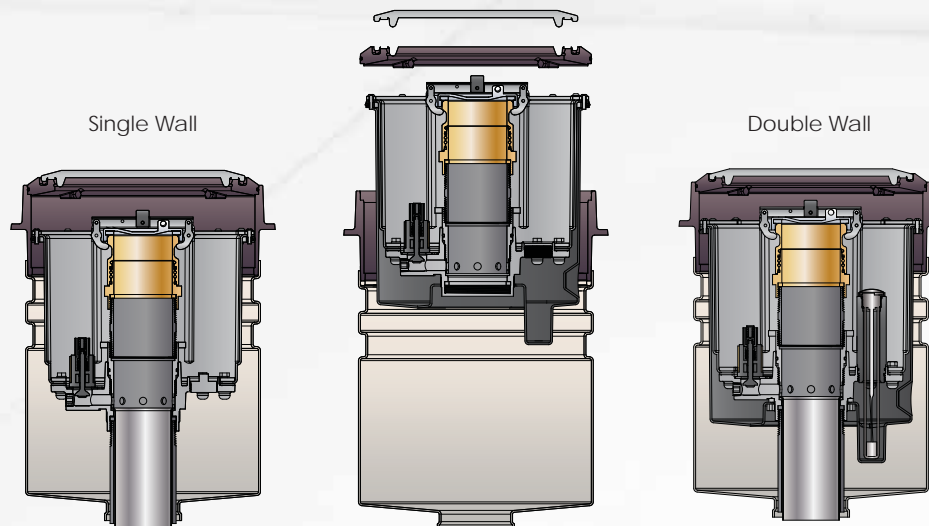



Franklin Fueling Systems

www.franklinfueling.com

3760 Marsh Road • Madison, WI 53718, USA

Tel: +1 608 838 8786 • Fax: +1 608 838 6433

Tel: USA & Canada 1 800 225 9787 • Tel: Mexico 001 800 738 7610

