



Six-way Air Valves

These air interlock valves were designed to operate two different air systems at the same time. The new lightweight valves are designed to lock the trailer brakes and open the air operated vapor valve at the same time. These six-way air valves can be used in the normally open (N/O) and normally closed (N/C) configurations of N/O, N/C, or N/O, N/O, or N/C, N/C positions. They have an adjustable stem and come standard with TTMA and API mounting holes.

Features

- Heat-treated, anodized aluminum construction.
- 1/4" NPT connection ports.
- Field serviceable.
- Adjustable stem button.

880-256-01

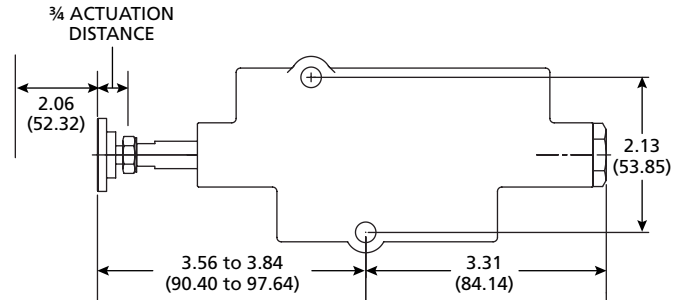
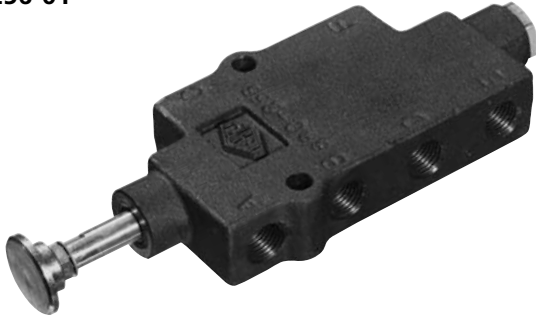

880-256-02

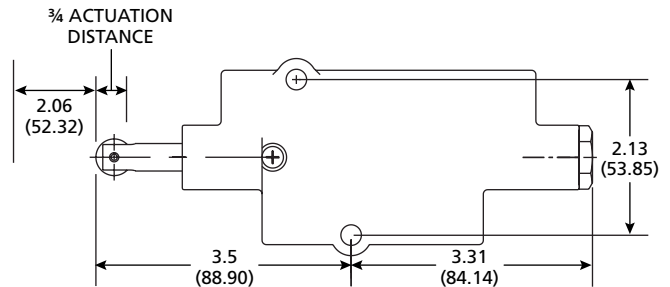

MODEL UNIT	880-256-01	880-256-02
Width (Inches/Millimeters)	3.00/76.2	3.00/76.2
Pounds	0.69	0.69
Kilograms	0.31	0.31



Six-way Air Interlock Valves Parts List

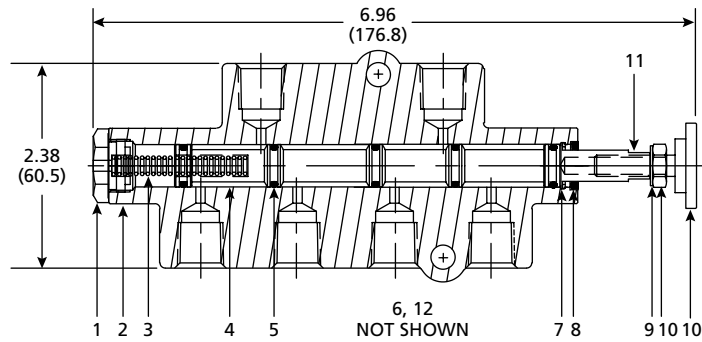

#	PART NAME	PART NUMBER	#	PART NAME	PART NUMBER
1	Plug - Nut	880-145-01	7	Retaining Ring	11090-04
2	Body - Air Valve	880-257-01	8	Dust Seal	880-142-01
3	Spring	880-148-01	9	Washer ¼ Int. Lock	11163-04
4	Spool & O-ring Assembly	880-258-01	10	Screw Adjuster 1.00" with Nut	880-144-02
5	Silicon Lube (5 PLCs)	11529-01	11	Anti-seize & Lubricant	11144-01
6	Screw ¼-20 x 1.5	11063-19	12	Washer ¼ Plain Stainless Steel	11275-02

PART NUMBER	DESCRIPTION
880-256-01	¼" - 1" Button Six-way Air Valve
880-256-02	¼" - 1" Roller Tip Six-way Air Valve