

BULK PNEUMATIC PRESSURE RELIEF VALVES

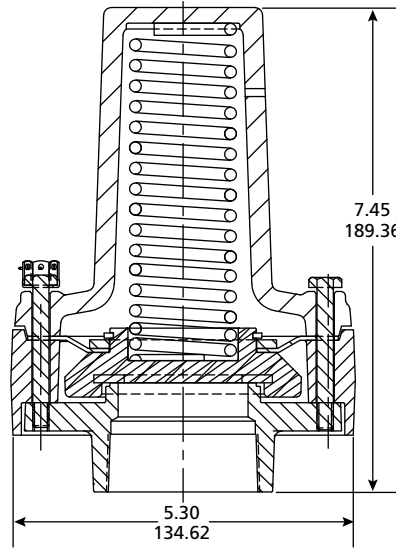

Three models are available, 15 lb pressure relief valve for the trailers, and 18 lb and 20 lb relief valves for the blower applications. All three models are available in either male or female 2" NPT thread. A unique three piece body that reduces ice build-up offers high air flow and reduces maintenance costs.

881-224-01



Features

- 2" female NPT mount.
- 3" male NPT mount.
- Tamper-proof seal.
- Reinforced silicone rubber diaphragm, rated -60 °F to +400 °F.
- Non-galling zinc-aluminum base.
- Unique three piece body reduces ice build-up, offers high air flow and ease of maintenance.



Non-galling zinc-aluminum base.

MODEL UNIT	881-221-01	881-222-01	881-223-01	881-224-01	881-225-01	881-226-01
Weight (Pounds/Kilograms)	6.4/2.90	6.4/2.90	6.4/2.90	6.4/2.90	6.4/2.90	6.4/2.90



**Bulk Pneumatic Pressure Relief Valves
Parts List**

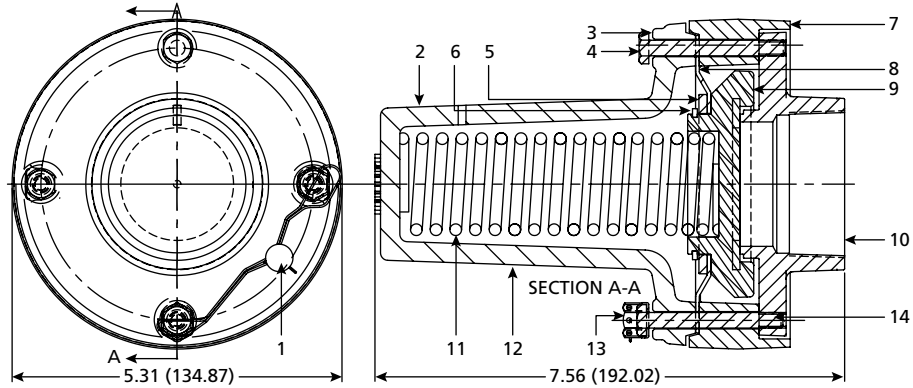

#	PART NAME	PART NUMBER	#	PART NAME	PART NUMBER
1	Tamper Proof Seal	11491-01	8	Relief Valve Diaphragm	881-143-01
2	Relief Valve Spring Cover	881-207-01AN	9	Relief Valve Poppet	881-142-02
3	Lock Washer ¼"	11177-01	10	Relief Valve Base	881-209-01
4	Hex Hd. Cap Screw	11176-24	11	Relief Valve Spring	11492-01
5	Relief Valve Spacer	881-144-01	12	Trailer Label	11497-01
6	Spirol Retaining Ring	11090-16	13	Safety Wire Locking Clips	11490-01
7	Relief Valve Body	881-208-01AN	14	Anti-seize	111444-01

PART NUMBER	DESCRIPTION
881-224-01	2" Female Pressure Relief Valve - 15 lbs
881-225-01	2" Female Pressure Relief Valve - 18 lbs
881-226-01	2" Female Pressure Relief Valve - 20 lbs
881-221-01	2" Male Pressure Relief Valve - 15 lbs
881-222-01	2" Male Pressure Relief Valve - 18 lbs
881-223-01	2" Male Pressure Relief Valve - 20 lbs