

Coaxial Hose

Installation Instructions

75 Series Model F2IS2I



Warning

Follow all federal, state, and local laws governing the installation of this product and the entire system. When no other regulations apply, follow NFPA 30, 30A, and 70 from the National Fire Protection Association. Failure to do so could result in severe injury, death, serious property damage and/or environmental contamination.



Warning

Highly flammable vapors or liquids may be present in the environment in which this equipment is installed or serviced. Installing or working on this equipment means working in an environment that presents risks of severe injury or death if instructions and standard industry practices are not followed. Follow all applicable codes governing the installation and servicing of this product and the entire system.



Danger

Always lock out and tag electrical circuit breakers while installing or servicing this equipment and related equipment. A potentially lethal electrical shock hazard and the possibility of an explosion or fire from a spark can result if the electrical circuit breakers are accidentally turned on during installation or servicing. Do not smoke while working on or near this equipment, and use only non-sparking tools.

Installation Procedure

1. The work area must be clean and have sufficient lighting.
2. Remove hose from carton and set aside package of kitted components (Kit Part # 849).
3. Identify hose end (swivel end) without o-rings on the vapor tube adaptor (see Figure 1).
4. From this hose end, remove retaining ring (see Figure 2) from vapor tube adaptor and set aside for re-use.

Note: To ensure re-use of the retaining ring, use the proper size retaining ring pliers to spread the ring just enough to clear and pull over the end of the vapor tube adaptor (see Figure 4).

5. From this hose end, also remove the flow restrictor (see Figure 3) and set aside for reuse.
6. From the other hose end (fixed end, non-swivel), carefully pull out the vapor tube assembly and set aside for re-use (see Figure 5).

Important:

The vapor tube assembly must be re-inserted into the same hose from which it came. If the vapor tube is installed in a different hose it may damage the vapor tube and cause coaxial hose problems.

Note: Use care when removing the vapor tube assembly to not kink the tube, damage the vapor tube adaptor quad rings, or lose the flow restrictor.

7. Feed the customer-supplied communications cable through the hose fittings.

Note: Customer-supplied communication cable to be gas and oil resistant, as well as meeting all applicable local codes for this application.

8. Re-insert the vapor tube assembly as previously removed in Step 6.
9. Re-insert the flow restrictor as previously removed in Step 5.
10. Re-insert the retaining ring as previously removed in Step 4.
11. Remove the larger o-rings from the kitted components package (set aside previously in Step 2) and assemble onto vapor tube adaptor on the hose end previously identified in Step 3 (see View 1).



Figure 1 – Adaptor (without O-rings)



Figure 2 – Retaining Ring



Figure 3 – Flow Restrictor

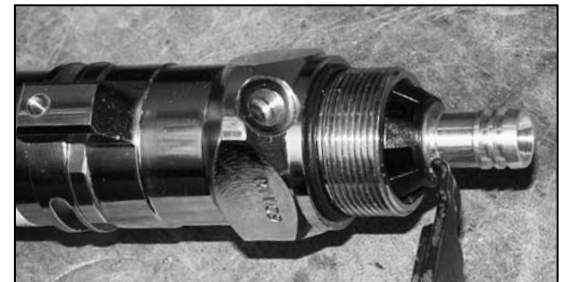

Figure 4 – Remove Retaining Ring with Pliers



Figure 5 – Pulling Vapor Tube Out

12. From the kitted components package, tighten down both ends of the communication cable as detailed in View 4. Use thread-locking sealant (Loctite 271 or equivalent) on the threads of the Plug (see View 4). Torque the Plug down finger-tight and then additional two full turns to ensure proper tightening of the cable.
13. Lubricate the O-rings (View 1), the Quad Rings (View 2) and O-rings (View 3, two places). Use of any weight motor oil as a lubricant is sufficient.
14. Assemble the end with the Quad Rings (View 2) to the output half of the Breakaway. Install the hose assembly and torque to 35 to 70 foot pounds. Assemble the end with the O-rings (View 1) to the nozzle.

Note: Be sure that the vapor tube fitting slides easily into the Breakaway's valve on the nozzle end before final tightening.

15. Terminate the customer-supplied communications cable to the customer-supplied communications system per the manufacturer's installation instructions.

Note: The integrity and operation of the customer-supplied communications components are the responsibility of the installer and customer.

16. Pressurize the system and test for leaks. If any leaks are found, lockout and tagout then troubleshoot the leaks.

Important: Once the system has been installed correctly, inspect daily for leaks.

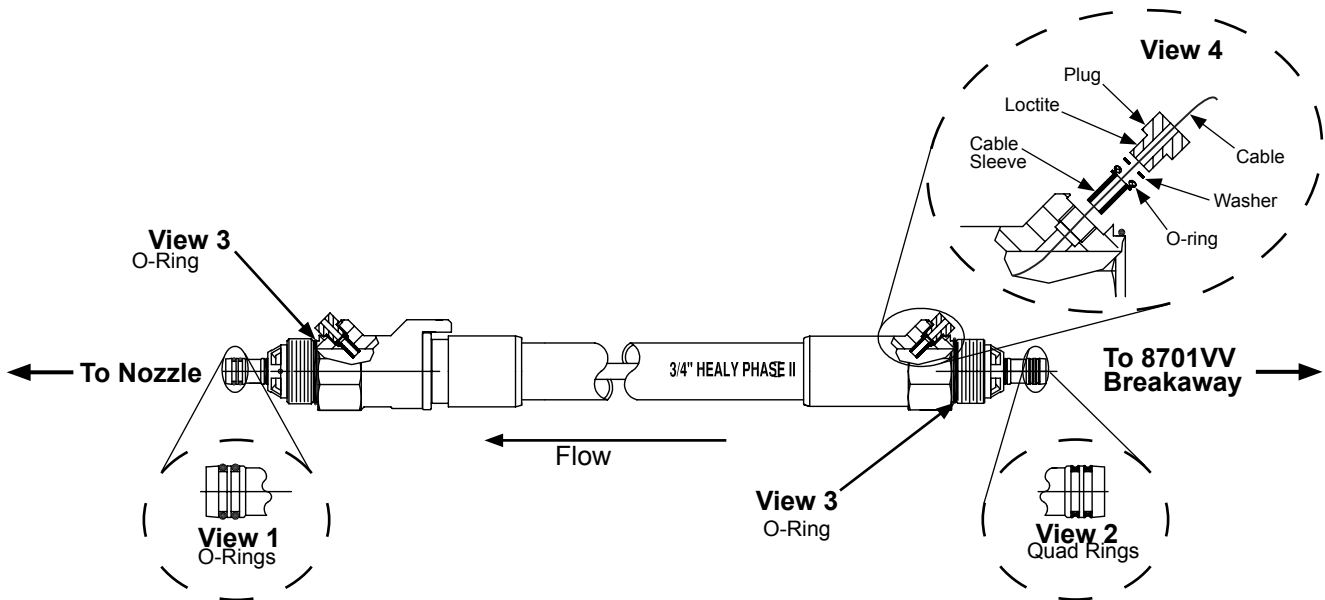

Franklin Fueling Systems

www.franklinfueling.com

3760 Marsh Road • Madison, WI 53718, U.S.A.

Tel: +1 608 838 8786 • Fax: +1 608 838 6433

Tel: USA & Canada 1 800 225 9787 • Tel: México 001 800 738 7610

Franklin Fueling Systems GmbH

Rudolf-Diesel-Strasse 20 • 54516 Wittlich, GERMANY

Tel: +49-6571-105-380 • Fax: +49-6571-105-510