



Franklin Fueling Systems



# Healy Mini-Jet, Part No. 940/940A

## Field Adjustment Procedure

### Important Notice

Healy 9000 Series Mini-Jet contains an adjustable vacuum regulator assembly. This assembly has been factory set at 70" to 85" water column (WC). Field adjustment is unlikely, however there might be some submerged turbine pump variations which would require fine tuning to assure the 70" to 85" WC setting. Read and carefully follow the instructions below.

### With no nozzles in operation:

- Start up the submerged turbine .
- Read the vacuum level in the underground vacuum vapor return piping. Use a 0-100" WC vacuum gauge (Healy Part No. 939349A). Vacuum should be 70" to 85" W.C.
- Adjust vacuum, if necessary, as follows:
  1. Remove the 1/4" pipe plug
  2. Slip a 5/16" thin-wall deep socket through the pipe tapped hole to secure the #5-40 hex nut in place.
  3. Insert a screwdriver with a 1/8" wide blade through the 5/16" thin-wall deep socket and engage the slot on top of the adjustment needle.

4. While holding the adjusting needle, turn the socket approximately one-quarter turn counterclockwise to loosen the nut.
5. While holding the nut, turn the needle clockwise to reduce vacuum or counterclockwise to increase volume.
6. Holding the needle in place, retighten the nut one-quarter turn clockwise. Remove the socket and screwdriver each time to check regulation. Readjust as required to reach the desired level.
7. Replace the plug when completed.

**Note:** Clockwise force on the nut while adjusting the needle could cause damage to the needle. If the nut is tight, hold the needle in place and loosen the nut one quarter turn counterclockwise with a 5/16" thin-wall deep socket.

**Note:** Regulator assemblies with damaged needle screw slots or torn diaphragms need to be replaced as a complete new assembly (Healy Part No. 940A). Because they are sealed to prevent leakage through the screw threads, the individual parts cannot be replaced.

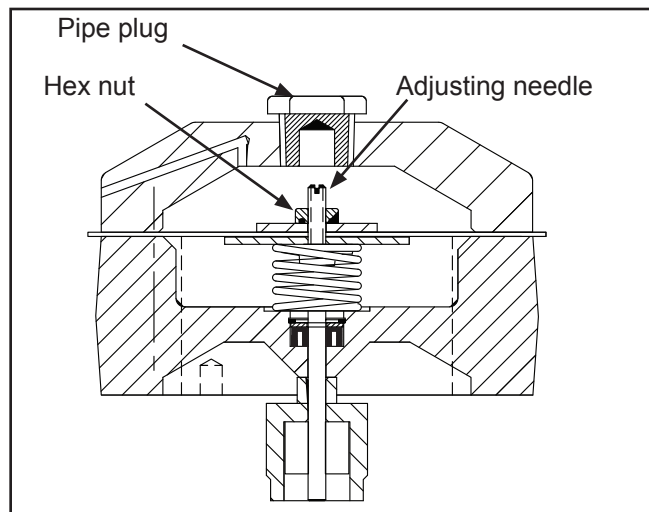

Figure 1: Mini-Jet Detail



Franklin Fueling Systems

www.franklinfueling.com

3760 Marsh Road • Madison, WI 53718, U.S.A.  
Tel: +1 608 838 8786 • Fax: +1 608 838 6433

Tel: USA & Canada 1 800 225 9787 • Tel: México 001 800 738 7610

Franklin Fueling Systems GmbH  
Rudolf-Diesel-Strasse 20 • 54516 Wittlich, GERMANY  
Tel: +49-6571-105-380 • Fax: +49-6571-105-510