

# **FIELD REPAIR INSTRUCTIONS**

## **9000 MINI-JET VACUUM PUMP**

### **IMPORTANT NOTE:**

The Healy Systems 9000 series Mini-Jet Vacuum Pump should be serviced by Healy qualified repair personnel only. The only field maintenance items are the **Part No. 912A Check Valve / Strainer Assembly**, where the screen may be clogged with debris and the **Part No. 940 Vacuum Regulator Assembly** which should be inspected for a torn diaphragm.

### **TO SERVICE:**

1. Shut off and lock out the submerged pump turbine (STP) associated with the Mini-Jet.
2. Remove the four bolts retaining the strainer cover and remove cover.
3. Look through the gasoline on top of the check valve and observe the  $\frac{3}{4}$ " hex-head of the valve retainer.
4. Remove this multi-holed retainer and the check valve is now loose.
5. Use a pair of screwdrivers (previous style valve) or pliers (recent valve) to pick up and remove valve.
6. Examine screen and remove debris, be sure screen and o-ring are in position to keep all foreign matter out of the orifice area.
7. Replace the valve and retainer into the casting.
8. Be sure the **Part No. 930 O-Ring** seal is in place on the top of the casting and replace the cover.
9. Install and tighten the four bolts.
10. Activate the system and check for leaks and proper vacuum level.

### **ADJUSTING THE VACUUM LEVEL:**

The 9000 Series Mini-Jets are factory set at 70" +/- 5" Water Column (WC) using 28-PSI product pressure. Mini-Jets will retain this regulation through a wide range of product pressures. Field adjustment is seldom necessary. When adjustment is necessary it is usually because there is TOO MUCH pressure. In this event, follow the steps below to calibrate the Mini-Jet to a proper setting.

**IMPORTANT NOTE:** If the **Part No. 940 Vacuum Regulator Assembly** is removed from the Mini-Jet, it is critical that the small hole in the bottom of the Vacuum Regulator Assembly be aligned with the small hole in the top of the Mini-Jet with the **small O-Ring (Part No. 965)** in place at reassembly. ***FAILURE TO DO THIS WILL CAUSE THE MINI-JET TO DEVELOP MAXIMUM VACUUM LEVELS!***

1. With no nozzles in operation, start up the STP and read the vacuum level in the underground vapor return piping. Use the **Part No. 939349A** 0-100" WC gage, the vacuum should be 70-85" WC. If the vacuum level is not in the specified range, make sure the Strainer Assembly is clean and a vapor return tightness line test is performed before adjusting vacuum.
2. Remove the  $\frac{1}{4}$ " pipe plug.
3. Slip a  $\frac{5}{16}$ " deep socket through the plughole and engage the #5-40 hex locknut in place.
4. Insert a  $\frac{1}{8}$ " wide blade screwdriver through the  $\frac{5}{16}$ " long socket and engage the slot on the top of the adjustment needle.

5. Hold the adjustment needle in position and turn the 5/16" socket counter-clockwise one-half to one turn to loosen the locknut.
6. While holding the loosened locknut in position, turn the needle clockwise to reduce vacuum or counter-clockwise to increase vacuum. After adjustment is complete, hold the needle in place and tighten the nut with the 5/16" long socket.
7. Reinstall the 1/4" pipe plug into the adjustment access hole.
8. If the vacuum level cannot be adjusted, visually inspect for a torn diaphragm and replace the 940 Vacuum Regulator Assembly if necessary, see "**IMPORTANT NOTE**" above.
9. If the vacuum level is uncontrolled when the cover plug is installed, but correct with the plug removed, the breather hole in the edge of the cover plate is blocked. Use a paperclip or 1/16" drill to clear the hole.

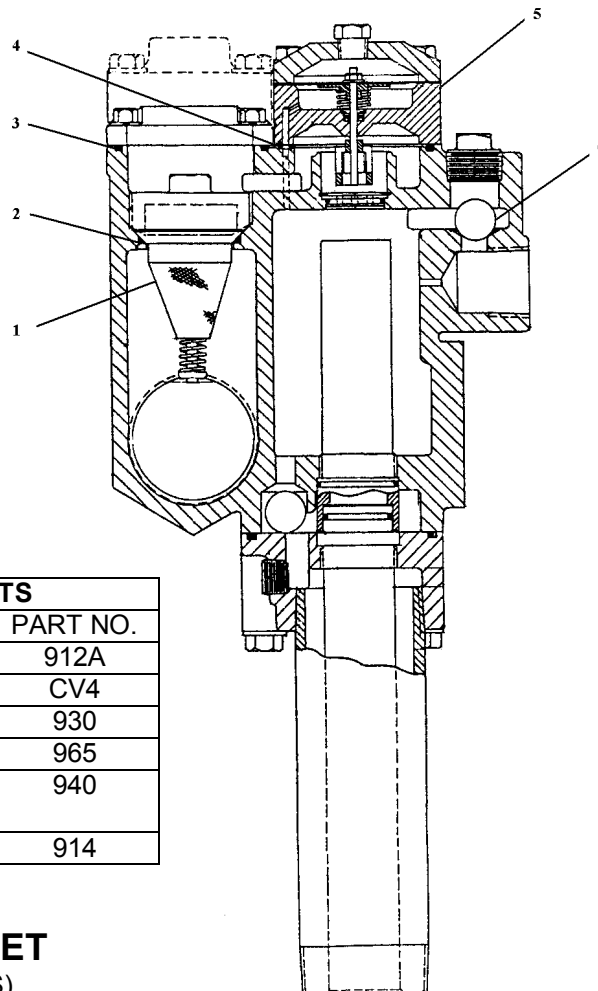

FIELD REPLACEABLE MINI-JET PARTS			
ITEM NO.	QUANTITY	DESCRIPTION	PART NO.
1	1	Strainer Assembly	912A
2	1	O-Ring	CV4
3	2	O-Ring	930
4	1	O-Ring	965
5	1	Vacuum Regulator Assembly	940
6	1	Float Ball	914

**HEALY 9000 SERIES MINI-JET**  
 (From Healy Dwg. D-9000-900, Rev. S)

**Figure 1.**