

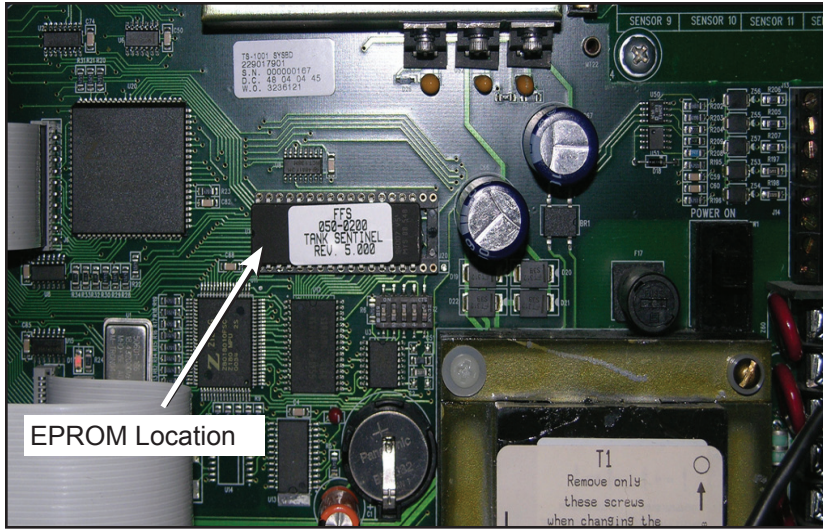

Franklin Fueling Systems

EPROM Software Upgrade Installation Instructions

for INCON Tank Sentinel® ATGs (Automatic Tank Gauges)



Newer Board EPROM

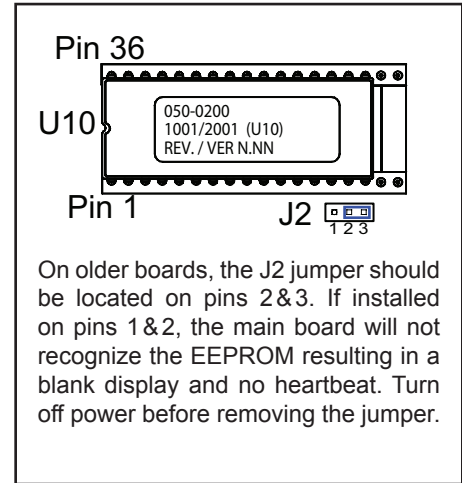

Older Board EPROM

Removal & Installation Steps

1. Printout or save the complete system and tank setup reports for all tanks.
2. Turn off power to the unit.



Electrical Shock Hazard. Make sure all safety shields are installed. Turn off all power going to any TS-IEM Internal Expansion Module(s).

3. Ground yourself to eliminate static electricity (touch the metal safety shield above the EPROM) and remove the older version EPROM (use a non-metallic tool, or wooden dowel to pry the older EPROM up at both ends) and pull it up using a gentle rocking-motion.
4. Ground yourself again (touch the metal safety shield above the EPROM) and remove the new EPROM from its packaging. Align the upgrade EPROM over its socket with the notched end facing left (as shown). Make sure each leg (pin) is positioned exactly above its mating socket.
5. Use your thumbs to seat the EPROM into its socket (press down at both ends).
6. Turn the power back on and reprogram the Tank Sentinel according to any special upgrade setup instructions that may be provided along with this instruction sheet.

Note: The Tank Sentinel console will require reprogramming after the EPROM is replaced.

If you have been instructed to “cold-boot” the console then you must save or printout the complete system setup and all tank setup reports before cold booting. These reports are essential because they show the most recent custom setup program and shorten the reprogramming task.

Have a spare roll of printer paper on hand before printing the reports. A cold-boot will require a total reprogramming of the tank gauge (because it deletes the old custom program and replaces it with a factory-default version). Preferably save your setup information with a laptop computer connected using System Sentinel and upload it after the cold boot process.

Contact FFS Technical Support at 800-984-6266 if you have questions about this upgrade.



Franklin Fueling Systems

www.franklinfueling.com

3760 Marsh Road • Madison, WI 53718, U.S.A.
Tel: +1 608 838 8786 • Fax: +1 608 838 6433
Tel: USA & Canada 1 800 225 9787 • Tel: México 001 800 738 7610

Franklin Fueling Systems GmbH
Rudolf-Diesel-Strasse 20 • 54516 Wittlich, GERMANY
Tel: +49-6571-105-380 • Fax: +49-6571-105-510