



Franklin Fueling Systems

DC400 Dispensing Cutoff System

404-4 Controller

Installation Instructions

Franklin Fueling Systems • 3760 Marsh Rd. • Madison, WI 53718 USA

Tel: +1 608 838 8786 • 800 225 9787 • Fax: +1 608 838 6433 • www.franklinfueling.com

Important Safety Messages

Franklin Fueling Systems (FFS) equipment is designed to be installed in association with volatile hydrocarbon liquids such as gasoline and diesel fuel. Installing or working on this equipment means working in an environment in which these highly flammable liquids may be present. Working in such a hazardous environment presents a risk of severe injury or death if these instructions and standard industry practices are not followed. Read and follow all instructions thoroughly before installing or working on this, or any other related, equipment.

As you read this guide, please be aware of the following symbols and their meanings:

Warning  This symbol identifies a warning. A warning sign will appear in the text of this document when a potentially hazardous situation may arise if the instructions that follow are not adhered to closely. A potentially hazardous situation may involve the possibility of severe bodily harm or even death.

Caution  This is a caution symbol. A caution sign will appear in the text of this document when a potentially hazardous environmental situation may arise if the instructions that follow are not adhered to closely. A potentially hazardous environmental situation may involve the leakage of fuel from equipment that could severely harm the environment.

Warning  **Follow all applicable codes governing the installation and servicing of this product and the entire system. Always lock out and tag electrical circuit breakers while installing or servicing this equipment and any related equipment. A potentially lethal electrical shock hazard and the possibility of an explosion or fire from a spark can result if the electrical circuit breakers are accidentally turned on during installation or servicing. Please refer to the Installation and Owner's Manual for this equipment, and the appropriate documentation for any other related equipment, for complete installation and safety information.**

Warning  **Follow all federal, state and local laws governing the installation of this product and its associated systems. When no other regulations apply, follow NFPA codes 30A and 70 from the National Fire Protection Association. Failure to follow these codes could result in severe injury, death, serious property damage and/or environmental contamination.**

Warning  **Always secure the work area from moving vehicles. The equipment in this manual is usually mounted underground, so reduced visibility puts service personnel working on this equipment in danger from moving vehicles entering the work area. To help eliminate these unsafe conditions, secure the area by using a service truck to block access to the work environment, or by using any other reasonable means available to ensure the safety of service personnel.**

Warning  **Use circuit breakers for multiple disconnect to turn off power and prevent feedback from other dispensers.**

Junction Box internal volume requirements per conductor:

| Size of Conductor (AWG) | Free space required for each conductor (in ³) |
|-------------------------|---|
| 18 | 1.5 |
| 16 | 1.75 |
| 14 | 2.0 |
| 12 | 2.25 |
| 10 | 2.5 |

List of Parts

| Description | Part Number |
|-----------------------------|-------------|
| QTY QuickON Wire connectors | 210-0083 |
| Controller | 404-4 |

List of Tools

- Industry-standard, non-sparking tools
- Allen wrench, 19mm
- Conduit and fittings as required, must be UL listed for use in Class I, Div 1 locations

Determine volume of Junction box. This information may be on the junction box itself usually expressed in cubic inches. If not, measure the inside length, width, and depth of the box and multiply these numbers together. This gives you the free volume of the junction box.

If the junction box is round measure the inside diameter and multiply this number by itself. Multiply this number by 0.78 and record this answer. Then measure the depth of the junction box and multiply it by the sum of your first answer. This gives the free volume of a cylindrical junction box.

Using the table above, subtract the cubic inches per each conductor which originates outside the junction box and terminates or is spliced within the junction box. Each conductor that passes through the junction box without splice or termination shall be counted once. Refer to National Electric Code 2011, article 314.16 (B).

Product Description

The DC400 system uses a sump sensor to detect the presence of liquid in the STP (Submersible Turbine Pump) or dispenser sump. If liquid is detected, the system will shut down power to the STP or dispenser.

The DC400 system consists of the 404-4 Controller and either a 2-Wire or 3-Wire sensor. Follow these instructions for installation of the 404-4 Controller. Franklin Fueling Systems sensors approved for use with the DC400 system come with their own installation instructions.

Specifications:

| | |
|------------------------------|--------------------------------|
| Input line voltage: | 90 – 250VAC 50/60 Hz |
| 404-4 power consumption: | 2W |
| Relay switch configuration: | SPST |
| Relay switch contact rating: | 12A continuous, 250VAC maximum |
| Operating temperature: | -20 to 60 degrees C |
| Hazardous location category: | Class I, Div 1, Group D |

Refer to Franklin Fueling Systems control drawing 000-1737

Installation for Dispenser Cutoff



Notice! Only qualified service technicians experienced with petroleum dispensing and pumping systems should install the DC400 system.



Notice! Do NOT exceed the 12A (continuous), 250VAC relay contact rating of this controller. Relay contacts are not fused.

Note: Install this kit ONLY in a UL listed dispenser.

Note: If there is no junction box or open port on the junction box, you cannot install this kit.

1. Shut off all power to the dispenser. Lock out and tag the corresponding dispenser circuit breaker.
2. Open/remove the dispenser lower panel for access to the dispenser hazardous area. Inspect the hazardous area to locate the dispenser explosion proof power entry junction box. The 404-4 controller will be wired into the dispenser via a spare conduit hub located on the dispenser power entry junction box.
3. Determine where to best locate the 404-4 controller and how best to plumb conduit from the dispenser spare conduit hub to the 404-4 controller. The 404-4 controller must be located so that regular servicing of the dispenser (such as changing of fuel filters) will not be impeded. The 404-4 controller can be located in the dispenser hazardous area or suspended down below the dispenser in the dispenser sump as room dictates. Refer to figure 1.

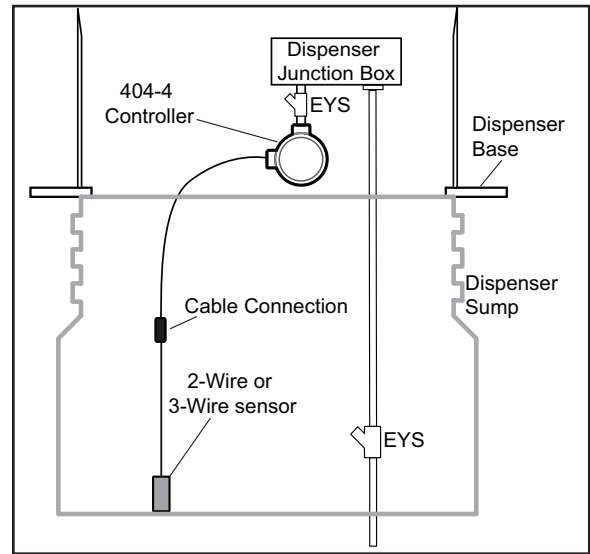

Figure 1: Typical System Installation in a Dispenser Sump

Note: Because each dispenser installation is unique it is impossible to provide a “one size fits all” conduit fitting kit. Necessary explosion-proof conduit and conduit fittings must be determined and supplied by the installer. The 404-4 controller conduit size is 3/4” NPT. Simple fittings such as elbows, sweeps, unions, and nipples should be used and must be UL listed and suitable for use in Class I, Div 1, Group D locations.

4. Open the dispenser power entry junction box cover and retain hardware for later use. Remove spare junction box plug and plumb explosion-proof conduit from the spare conduit entry hub to the 404-4 controller power port (the port with 6 wires protruding). Thread the 6 wires coming out of the power port of the 404-4 controller through the conduit to the dispenser power entry junction box.

Important! Be sure installation of conduit, fittings and wiring is in accordance with local, State and National electrical codes. A conduit seal must be installed between the dispenser J-box and the controller. The conduit seal must be within 18" of the dispenser J-box and the 404-4 controller. Refer to NEC NFPA 70, article 501.15 (A) (3), 2011. Make sure the dispenser power entry junction box has enough spare room to accommodate the additional 404-4 controller wires (see the table on page 2). Important! When tightening the conduit to the 404-4 controller, use a wrench on the conduit fittings and not the 404-4 controller body.

5. Wire the 404-4 power wiring per the schematic that matches your dispenser listed in Figures 7 - 14. Contact your dispenser manufacturer for a wiring diagram if you are unsure of the dispenser input power wiring.



Make sure to connect both ground wires and verify they are connected to earth ground. Failure to do so may result in a fire or explosion hazard in case of a fault condition.

- Connect the sensor wire cable coming from the 404-4 controller to the appropriate Franklin Fueling Systems sensor. Refer to the sensor's installation instructions for installation, wiring and testing of the sensor.

The sensor must be installed in accordance with the sensor's control drawing and with Franklin Fueling System's control drawing 000-1737.

- Double check all dispenser & controller power wiring to be sure it is correct then replace the dispenser power entry junction box cover. Secure the cover with all of the bolts previously retained.
- Turn the dispenser power back on. The dispenser should operate normally.
- Replace and secure lower dispenser door(s).
- Test the DC400 dispenser cutoff by submerging the sensor in water. The dispenser should shut off and remain off as long as the sensor is submerged.

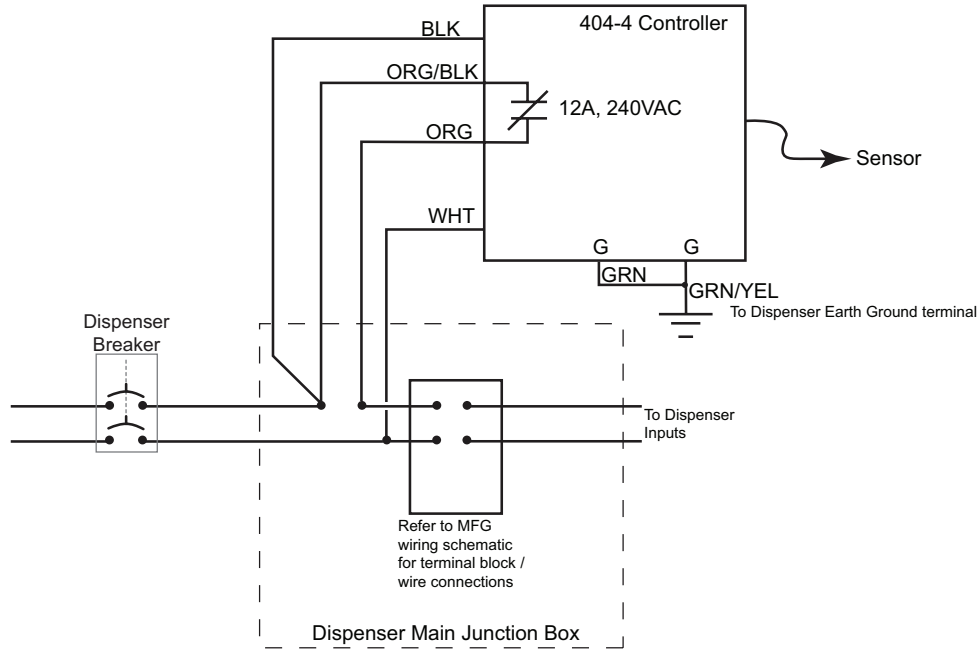



Figure 2: Power Wiring Schematic for Controller Dispenser Connection

Installation for Submersible Pump Cutoff

Notice! Only qualified service technicians experienced with petroleum dispensing and pumping systems should install the DC400 system.

Warning  **This controller is NOT for use with 3-phase pumps or Variable Frequency Drive pump installations.**

Notice! Do not exceed the 12A (continuous), 250 VAC relay contact rating of this controller. Relay contacts are not fused. This controller is suitable for most submersible pumps rated up to 2 hp @ 250 VAC and 1½ hp @ 120 VAC, provided the maximum pump motor service factor amperage is 12A or less. Contact the submersible pump manufacturer if in doubt.

Warning  **Remove power to avoid possible electrocution or ignition of explosive gasoline vapors.**

- Shut off power to the STP. Lock out and tag the corresponding STP circuit breaker.
- In pump cutoff installations the 404-4 controller will be connected directly to the integral electrical junction box on the STP via rigid explosion proof conduit. Since STP sump installations can vary, the installer will need to determine where best to place the controller in the sump and then procure

the necessary conduit and fittings.

A typical means of connecting the controller to an STP via an explosion proof union is shown in Figure 3. All fittings must be UL listed and suitable for use in a Class I, Div 1, Group D environment.

If the STP junction box does not have a removable plug or opening, installation adapters are available as listed below.

| Installed STP | Installation Adapter |
|--------------------|----------------------|
| FE Petro | TS-FE |
| Red Jacket | TS-RJ |
| Red Jacket Quantum | TS-RJQ |

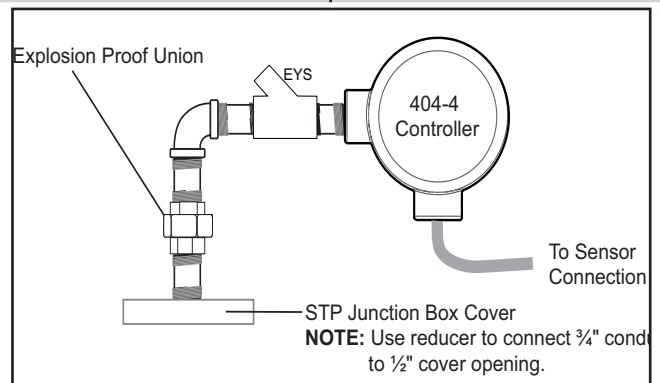

Figure 3: Typical Connection to STP

- Remove the STP junction box cover/plug. Make sure the STP junction box has enough room to accommodate the additional 404-4 controller wires (see the table on page 2). Thread the six 404-4 power wires from the power port through the conduit fittings and plumb the conduit fittings to the 404-4 controller. Connect the controller power wires to the STP wiring as shown in figure 4.



Make sure to connect both ground wires and verify they are connected to earth ground. Failure to do so may result in a fire or explosion hazard in case of a fault condition.

- Join the controller conduit to the STP junction box cover and replace the cover on the STP and securely tighten. A union will be required to do this, (see Figure 3). A conduit seal must be installed between the electrical junction box and the controller. The conduit seal must be within 18" of the electrical junction box and the 404-4 controller. Multiple conduit seals may be required for some installations, depending upon the distance between the electrical junction box and the 404-4 controller. Refer to NEC NFPA 70, article 501.15 (A) (3), 2011.
- Connect the sensor wire cable coming from the 404-4 controller to the appropriate Franklin Fueling Systems sensor. Reference the sensors installation instructions for installation, wiring and testing of the sensor.
- Turn the STP circuit breaker back on and test the DC400 system for proper operation. With the sensor dry, the STP should operate normally.

- Next, test the DC400 pump cutoff by submerging the sensor in water. The pump should shut off and remain off as long as the sensor is submerged. (Note: if the pump is controlled and monitored by an external pump controller or tank gauge, this device may need to be reset when the sensor is removed from the water).

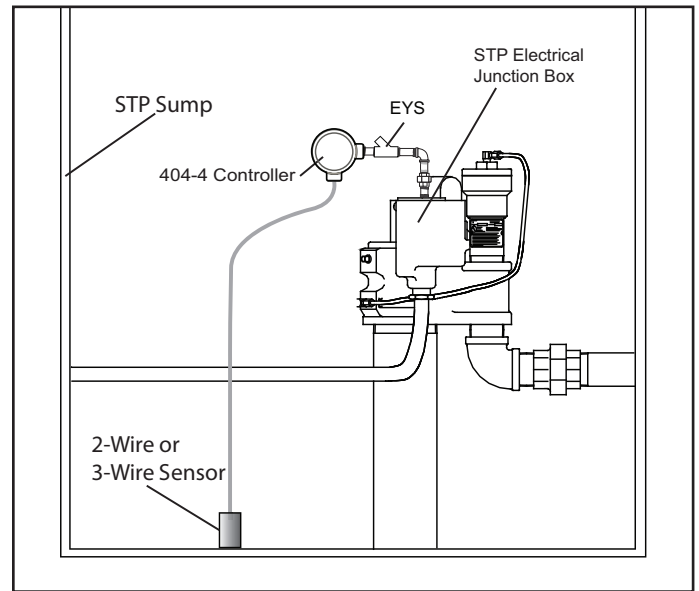

Figure 5: Typical STP Sump Installation

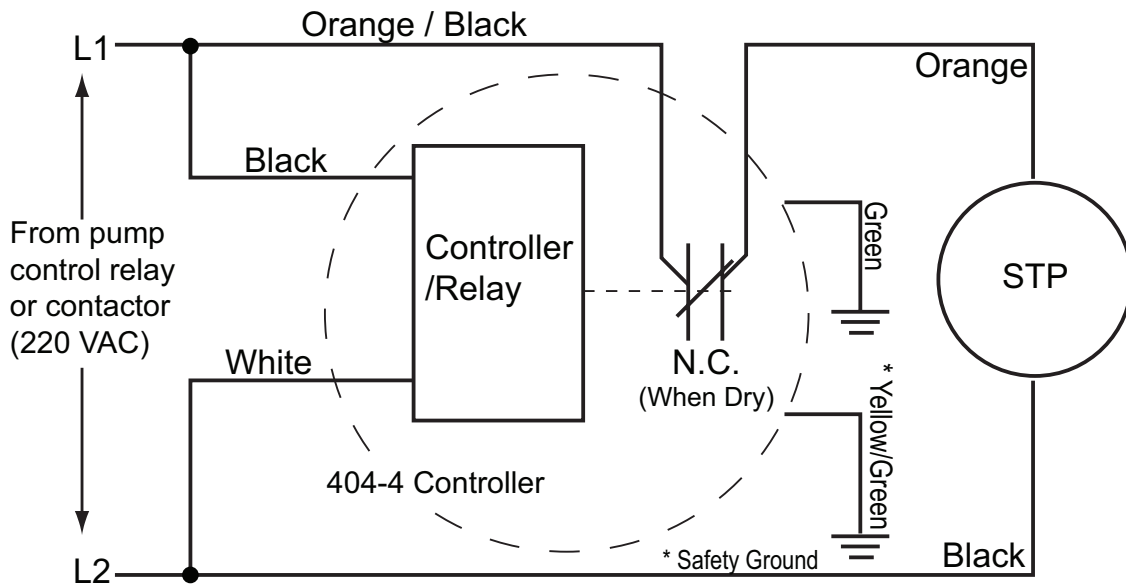

Figure 4: Power Wiring Schematic for STP Connection

Installation for Alarm Wiring

Important! For all applications, do not exceed the relay contact rating of 250VAC, 12A.

The relay contacts (Orange/Black and Orange wires) on the 404-4 controller are normally closed dry contacts (when power to the controller is applied) that will open when liquid is detected. This enables the DC400 to be wired for various alarm notification and monitoring.

Figure 6 shows an example of alarm wiring for applications that do not require positive shutdown but simply some sort of visual and/or audible notification. In this example the alarm light illuminates when the DC400 detects liquid.

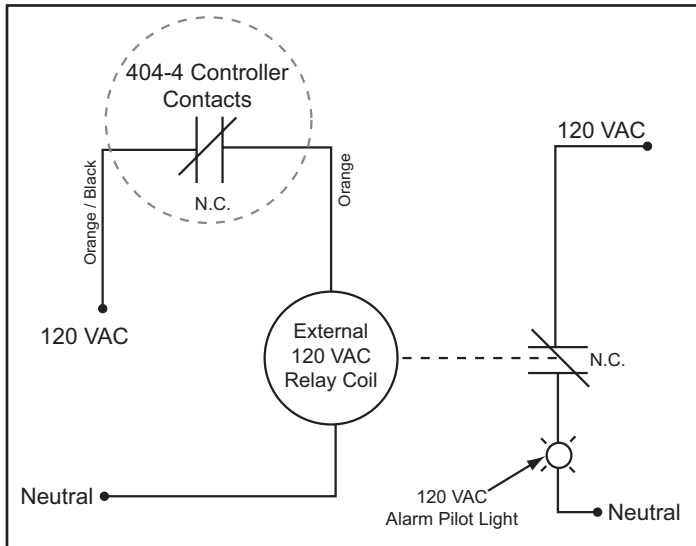

Figure 6: Wiring Example for Non-Positive Shutdown

Testing

Test the function of the system according to applicable codes. Test immediately after installation, and at least annually to verify proper system operation.

Troubleshooting

If the controller relay repeatedly cycles or oscillates when the sensor is tripped, it is likely that the controller is switching its own power. Check the wiring diagram and confirm that the controller is wired properly. Make sure that the orange/black, red and black wires are tied to power from the breaker and the orange wire feeds the dispenser. If problems continue, please contact FFS Technical Support at 800-984-6266.

Dispenser-Specific Wiring

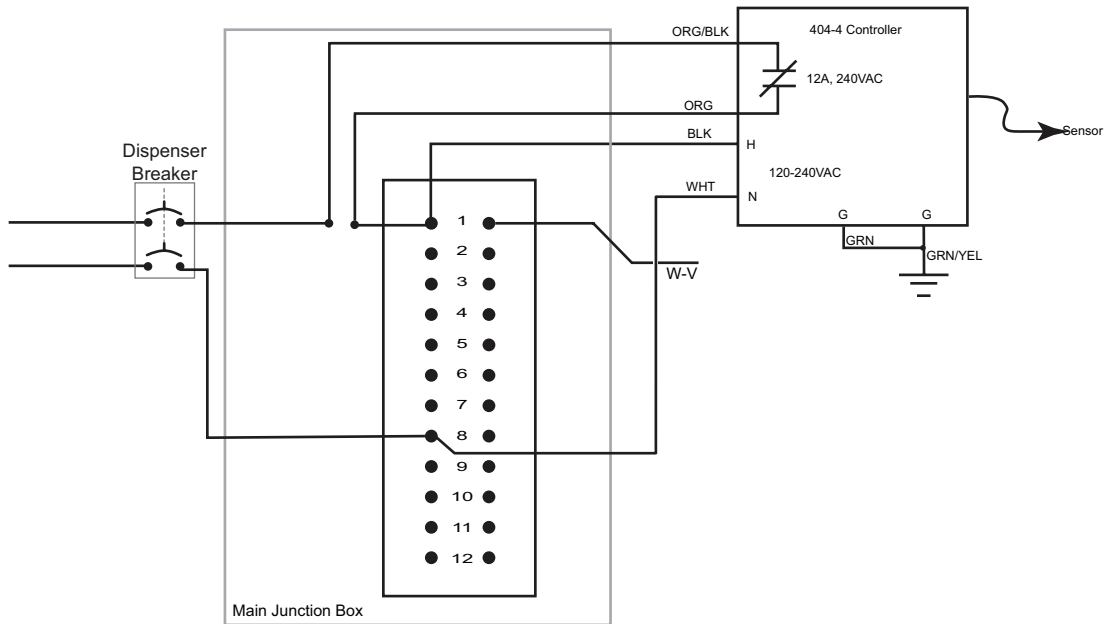

Figure 7: 404-4 Wired to a 120V Dresser-Wayne Vista 3 Series Dispenser

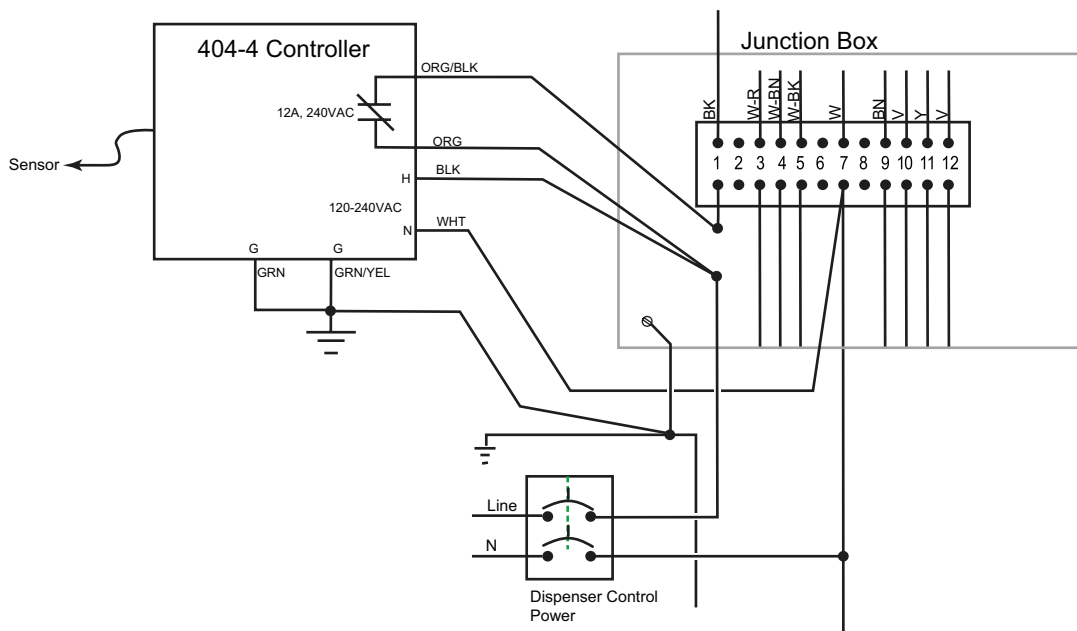

Figure 8: 404-4 Wired to a Dresser Wayne Ovation Dispenser

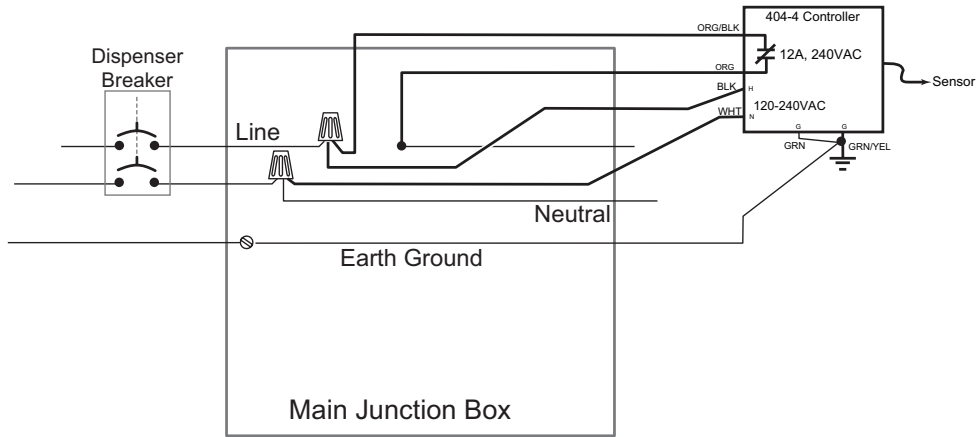

Figure 9: 404-4 Wired to a Gilbarco Eclipse Dispenser

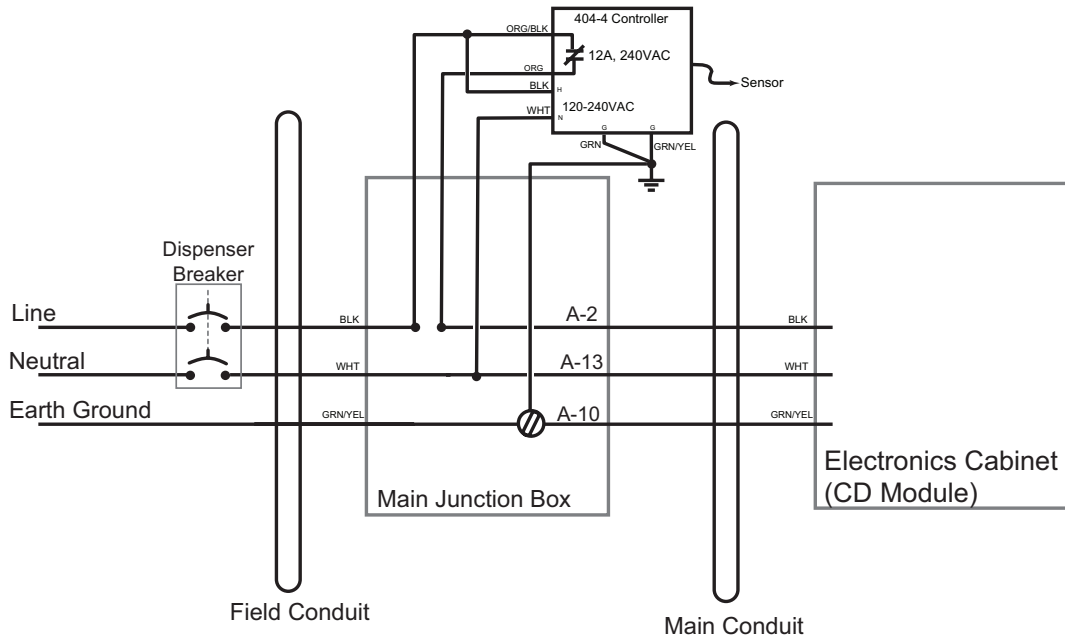

Figure 10: 404-4 Wired to a Gilbarco Encore 300 or 500 Dispenser

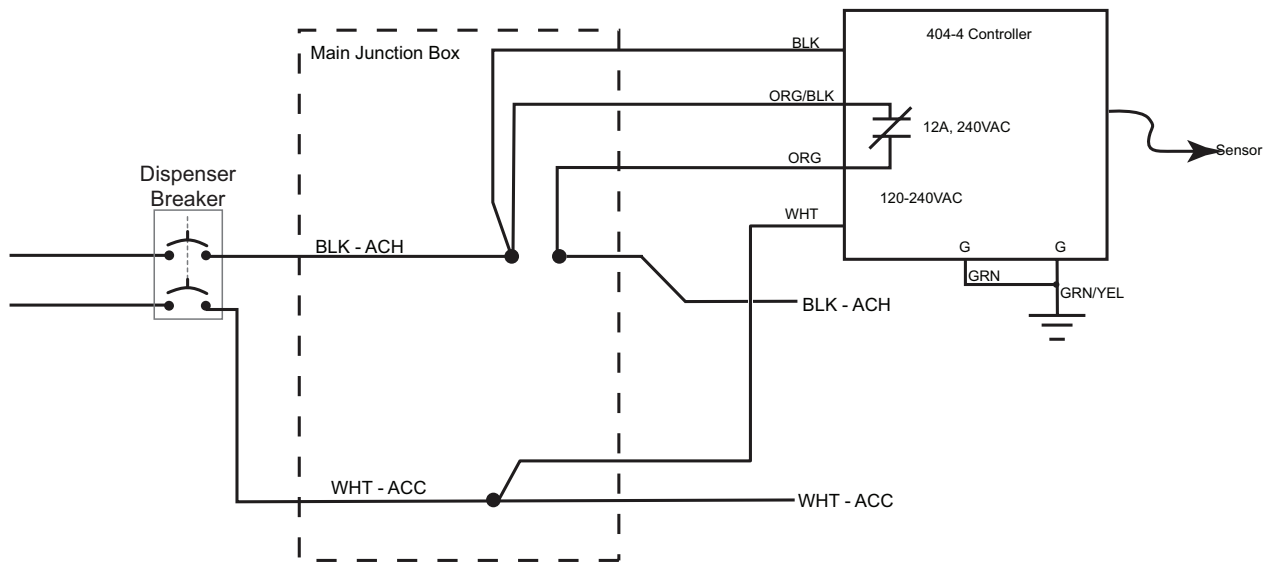

Figure 11: 404-4 Wired to a Tokheim 262 or 262A Dispenser

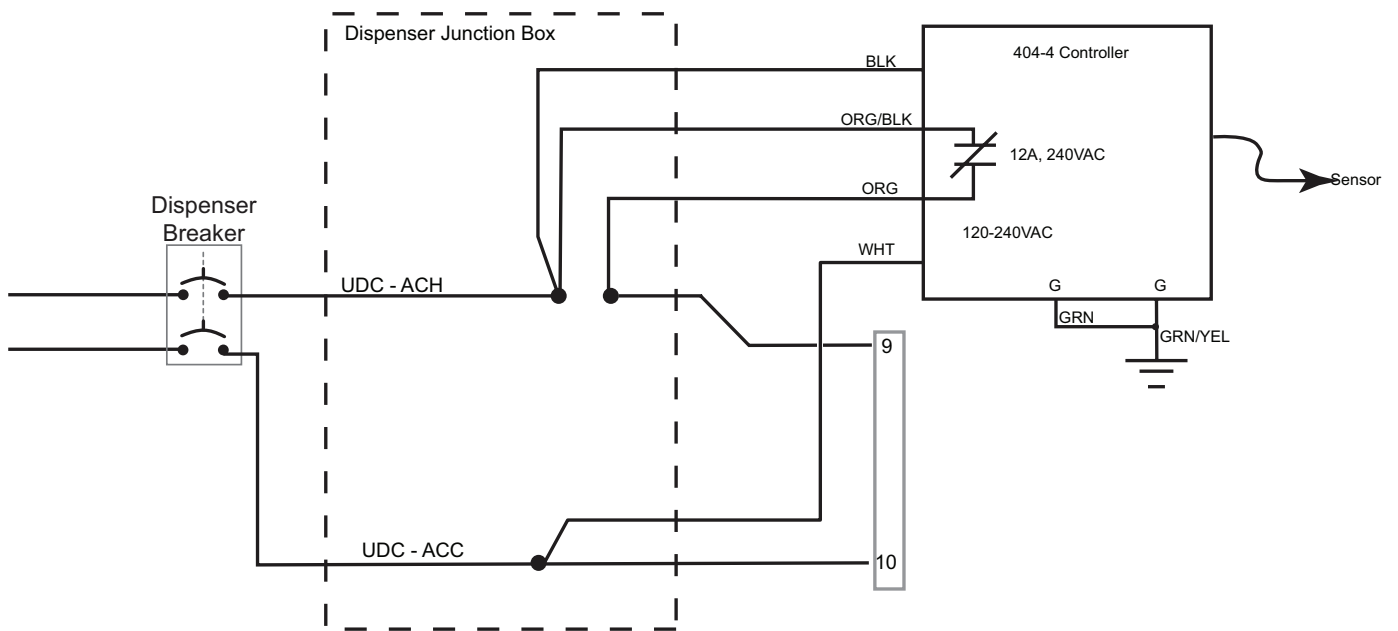

Figure 12: 404-4 Wired to a Tokheim Premier Dispenser

Page intentionally blank

Page intentionally blank



Franklin Fueling Systems

www.franklinfueling.com

3760 Marsh Road • Madison, WI 53718, U.S.A.

Tel: +1 608 838 8786 • Fax: +1 608 838 6433

Tel: USA & Canada 1 800 225 9787 • Tel: México 001 800 738 7610

Franklin Fueling Systems GmbH

Rudolf-Diesel-Strasse 20 • 54516 Wittlich, GERMANY

Tel: +49-6571-105-380 • Fax: +49-6571-105-510