

# TSP-LL2

## Magnetostrictive Probe

### Installation

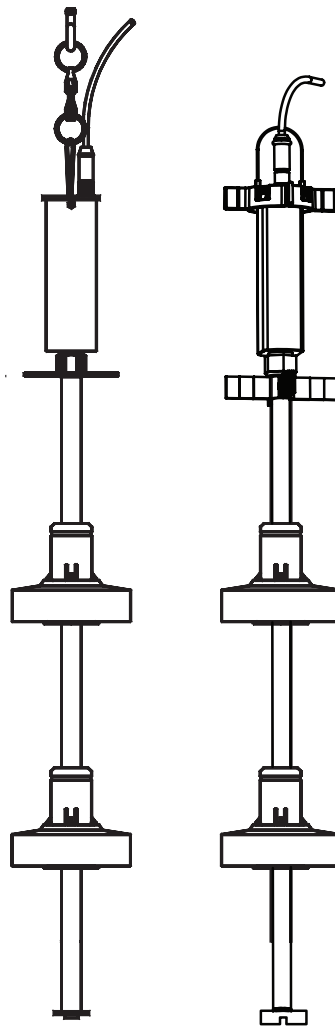

## Safety

### Warning



Always lock out and tag electrical circuit breakers while installing or servicing this equipment and any related equipment. A potentially lethal electrical shock hazard and the possibility of an explosion or fire from a spark can result if the electrical circuit breakers are accidentally turned on during installation or servicing. Please refer to the Installation and Owner's Manual for this equipment, and the appropriate documentation for any other related equipment, for complete installation and safety information.

### Warning



Follow all federal, state and local laws governing the installation of this product and its associated systems. When no other regulations apply, follow NFPA codes 30, 30A and 70 from the National Fire Protection Association. Failure to follow these codes could result in severe injury, death, serious property damage and/or environmental contamination.

### Warning



Always secure the work area from moving vehicles. The equipment in this manual is usually mounted underground, so reduced visibility puts service personnel working on this equipment in danger from moving vehicles entering the work area. To help eliminate these unsafe conditions, secure the area by using a service truck to block access to the work environment, or by using any other reasonable means available to ensure the safety of service personnel.

### Warning



When the console system is used to monitor tanks containing gasoline or other flammable substances, you may create an explosion hazard if you do not follow the requirements in this manual carefully.

### Warning



All wiring must enter the console's enclosure through the designated knockouts. An explosion hazard may result if other openings are used.

### Warning



All wiring from probes to the console must be run in conduit separate from all other wiring. Failure to do so will create an explosion hazard.

## Overview of LL2 Probe

The INCON LL2 probes are advanced instruments that use magnetostrictive position measurement technology to accurately report inventory levels in storage tanks

The probes are installed in USTs (underground Storage Tanks) and ASTs (above ground storage tanks). Leak Detection probes are suspended by a chain from a cap on the riser pipe. Inventory probes may be suspended by a chain and cap or alternatively be mounted on the bottom of the tank. Bottom mount hardware is provided on all inventory probes.

## Types of Probes

- Leak Detection
- Inventory Specific

## Length of Probes

The probe model number indicates its length. The model numbers are in the form TSP-LL2-xxx, where xxx = the tank diameter in inches plus 5.

For example, the TSP-LL2-101 is for 8' (96") tanks.

TSP-LL2-xxx, Leak Detection and Inventory probes are available in lengths up to 12' tanks.

TSP-LL2-xxx-I, Inventory Specific probes are available in lengths up to 18' tanks.

TSP-MLGK-xx, Moorman Level Gauge Kits are available for tanks up to 35' and up to 50'. Refer to manual 000-2033 for Moorman Gauge installation.

## Float Kits Available

| Model    | Description   |
|----------|---|
| TSP-IDF2 | 2" float set for diesel tanks   |
| TSP-IGF2 | 2" float set for gasoline tanks   |
| TSP-IDF3 | 3" float set for diesel tanks   |
| TSP-IGF3 | 3" float set for gasoline tanks   |
| TSP-IDF4 | 4" float set for diesel tanks   |
| TSP-IGF4 | 4" float set for gasoline tanks   |
| TSP-LPGF | 2" float for LPG tanks, with or without isolation sleeve. See manual 000-0251 for more information. |
| TSP-SSP  | 2-1/16" OD, #316 stainless steel float for chemical applications only                               |

Each float kit includes a product and water float. Order one float set for each LL2 Mag probe.

- Product floats are white (clear)
- Gasoline water floats are red.
- Diesel water floats are blue

## Probe Installation Kits

### Suspended Probe Kits

| Model    | Description   |
|----------|---|
| TSP-K2A  | Mag Probe install kit for 2" riser pipe                       |
| TSP-K2B  | Mag Probe install kit for 2" riser pipe with BSP threads      |
| TSP-K4A  | Mag Probe install kit for 4" riser pipe                       |
| TSP-K4B  | Mag Probe install kit for 4" riser pipe with BSP threads      |
| TSP-K4AS | #316 Stainless Steel mag probe install kit for 4" riser pipes |
| TSP-LPGK | LPG Probe install kit, 149" maximum LL2 probe length          |

### Inventory Control Probe Caps and Adapters (for bottom-mounted probes)

| Model   | Description   |
|---------|---|
| TSP-C2A | Inventory Probe 2" Riser Cap and Adaptor                  |
| TSP-C2B | Inventory Probe 2" Riser Cap and Adaptor with BSP threads |
| TSP-C4A | Inventory Probe 4" Riser Cap and Adaptor                  |
| TSP-C4B | Inventory Probe 4" Riser Cap and Adaptor with BSP threads |

A locally supplied riser cap for Inventory Control Probes should meet all applicable codes and approvals. The cord grip must be for use with a cable diameter of 0.19 inches (4.8mm) and must also be compatible with the liquid installed in the tank.

## Density Floats

Density floats are two-part floats. The inner and outer float are calibrated at manufacture and must be used together.

| Model     | Description                 |
|-----------|-----------------------------|
| TSP-IDF4D | Diesel/Fuel Oil Density Kit |
| TSP-IGF4D | Gasoline density float kit  |

Refer to manual 000-0527 for more information about density float installation.

## Riser Pipe

Below is a example for determining riser length.

|                                  | 92" Tank | 96" Tank |
|----------------------------------|----------|----------|
| TSP-LL2-101 Probe Overall Length | +111     | +111     |
| Suspension chain allowance       | +5       | +5       |
| Total                            | +116     | +116     |
| Tank Diameter                    | -92      | -96      |
| <b>Minimum Riser Length</b>      | 24       | 20       |

## Installing Floats

For TSP-LL2 probes the float(s) will need to be installed on the probe.

1. Carefully remove the E-Clip and washer/bottom mount foot.
2. Install the floats as shown in figure 2.
3. Reinstall the Washer/bottom-mount foot and E-Clip.

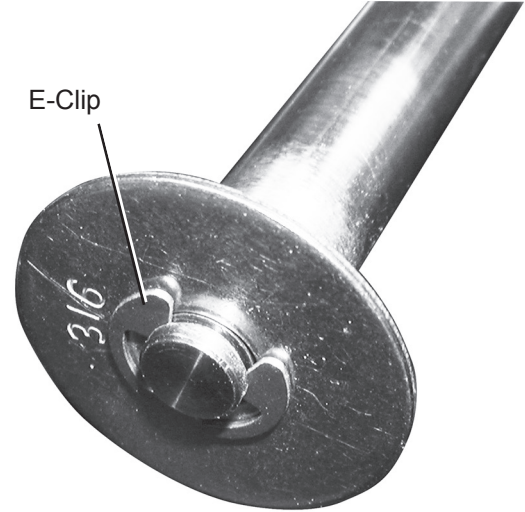

Figure 1: Probe C-Clip and Washer

### Float orientation

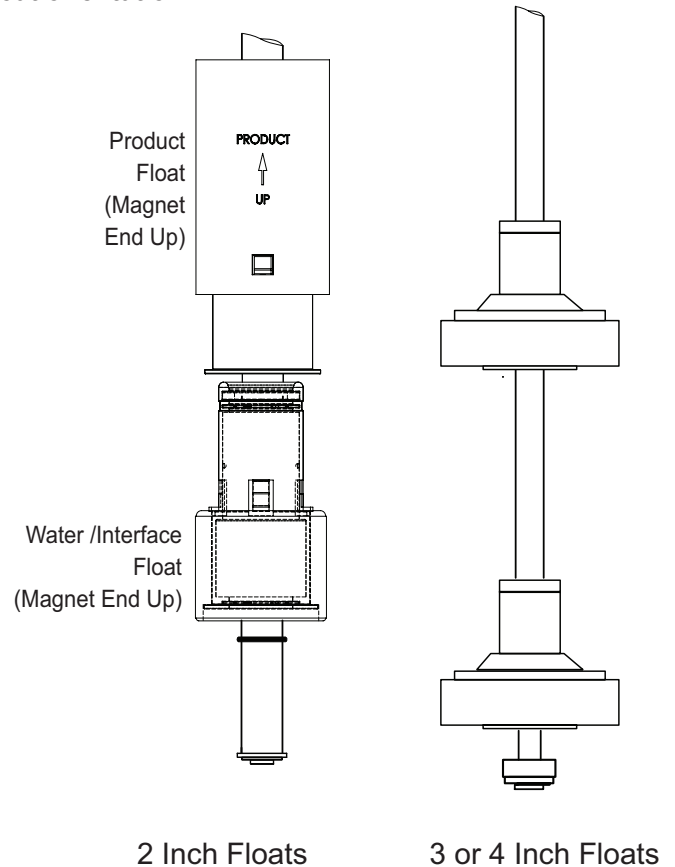

Figure 2: Float Orientation

## Suspended Probe Installation

This procedure must be done with leak detection probes and is optional for inventory probes. Before starting the probe installation, be sure that you have the necessary hardware:

- Level probe(s)
- Product and water floats,
- Probe installation kit.

### For each tank, locate the following:

- LL2 level probe
- Product float
- Water float-optional, is identified by color: (Blue–Diesel, Red–Gasoline)
- Threaded adjustment eye bolt and suspension chain (with wing nut and split ring attached)\*
- Steel support plate (with rubber grommet and insulating washer installed)\*
- Four Inch NPT riser adaptor\*
- Riser cap\*
- Compression gland seal fitting (cord grip)\*
- (3) Moisture resistant, no strip, electrical wire splice connector\*

\* Included in the TS-K4A probe installation kit.

### Installation

1. Measure from the top of the riser pipe to the bottom of the tank-record value in inches.
2. Measure the overall length of Probe.
3. Subtract the probe length from the distance measured from the top of the riser pipe to the bottom of the tank, and then add 1/2 inch to this distance. This value is the **TOTAL LENGTH OF THE CHAIN INCLUDING THE SPLIT RING AND ADJUSTMENT EYEBOLT.**
4. The suspension chain must be cut to the exact length required.
5. Remove the split ring from the end of the chain and cut the chain to the correct length.
6. Reattach the split ring to its end and measure the total overall length to make certain that it is within one half inch of correct value.

Note; When using a 2" or 3" riser you will replace the bottom spacer with the 3" spacer included in the float kit. When using a 2" riser, cut back the spacer at the marks. The 4" probes are installed with no modification.

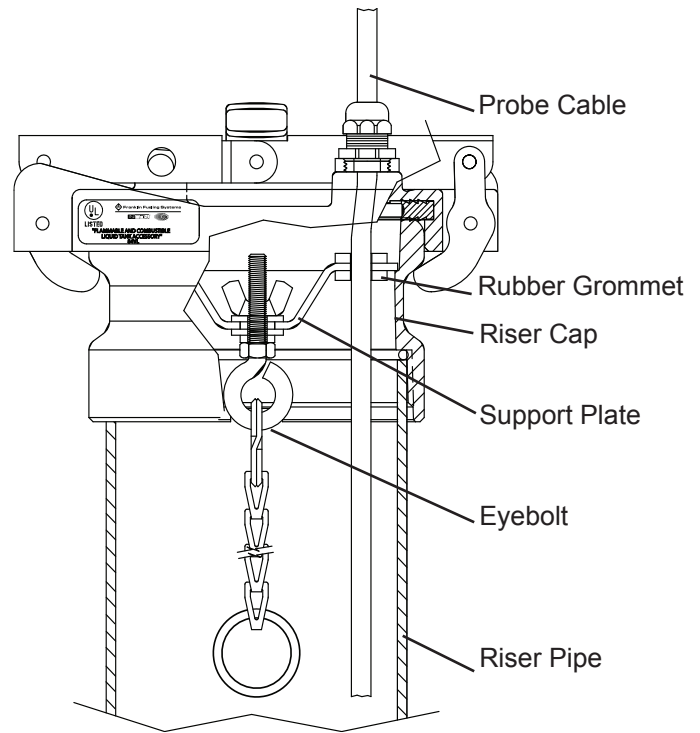

**Figure 3: Installation of Suspended Probe**

7. Apply pipe sealant to the male riser threads.
8. Screw the riser cap adapter into the top of the riser pipe. Tighten to 20-25 ft-lbs.
9. Connect the probe to the split ring on the chain.
10. Carefully position the steel support plate containing the rubber grommet and insulating shoulder washer into the riser cap.
11. Guide the probe cable through the rubber grommet.
12. Unscrew the adjusting eyebolt so the probe just touches the bottom of the tank.
13. Turn the wing nut clockwise, 4 full turns (only). This will raise the probe approximately 1/4" above the bottom of the tank.
14. Push the probe cable through the compression fitting on the probe cap.
15. Install the probe cap on the riser cap adapter such that the compression fitting is aligned with the rubber grommet.
16. Tighten the compression fitting to make a watertight seal.

### Adjusting the probe height (1/4" off the bottom of tank)

Make sure the probe is sitting on the bottom of the tank by loosening the wing nut until you feel slack in the chain (the probe is resting on the bottom of the tank). Then turn the wing nut clockwise until you feel that there is no slack in the suspension chain. Hold the end of adjustment rod and turn the wing nut clockwise, 4 full turns (only). This will raise the probe approximately 1/4 of an inch above the bottom of the tank.

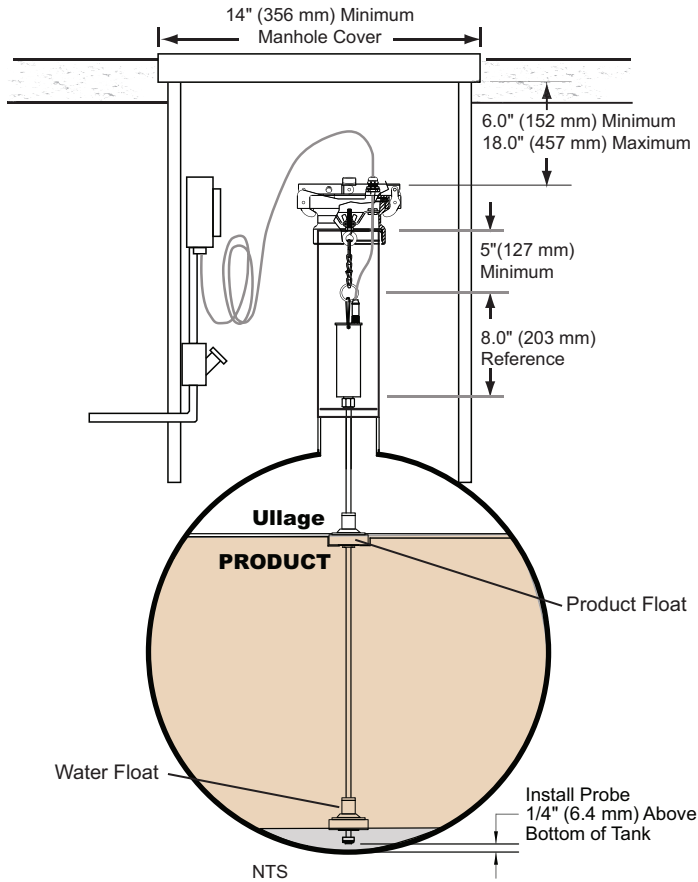

Figure 4: Suspended Probe Installed

### Final Suspended Probe Installation Steps

1. Push the probe's cable through the compression gland fitting at the waterproof junction box. Make sure that you leave enough cable from the level probe to the junction box (tie-wrap a coiled service loop) so that the probe can be easily removed and reinstalled without rewiring and splicing.
2. Tighten the compression gland fitting at the junction box so that it grips the cable tightly and creates a watertight seal.
3. Position the lockable TSP-K4A probe cap on the riser cap adapter such that the compression fitting is aligned with the rubber grommet and snap it in place.
4. Tighten the riser cap compression fitting so that it grips the cable tightly and forms a watertight seal

Note: When removing the probe, loosen the cable compression fitting.

### Bottom-Mount Probe Installation

The bottom-mount probe option is for inventory control probes. Tank leak testing and density probes need to be suspended from the riser cap.

The bottom-mount assembly consists of:

- Top spacer on the top of the probe head for 3" or 4" probes
- Bottom spacer below the probe head
- Probe foot mounts at the bottom of the probe shaft

The foot is 1/4" thick so when installed the probe end will be 1/4" off the bottom of the tank.

When using a 2" riser you will remove the top spacer and replace the bottom spacer with the 2" spacer included in the float kit. When using a 3" riser, cut back the top spacer and replace the bottom spacer with one included in the float kit. The 4" probes are installed with no modification. This is solely for the I-probes, all leak detection and density probes MUST BE Suspended.

### Single Thermistor Probe

The probe will have one RTD near the bottom of the probe shaft. The Net Volume will be based on the one temperature reading vs. the average of the 5 RTDs in current Inventory probes.

**Note:** The Inventory Probes MUST NOT be used for Leak Detection.

A sticker on the head of the I-probe indicates that it is for inventory use only. An extra sticker is provided to be kept near the console for gradient programming. Installers must be aware of the probe type in sites that have a mix of inventory-specific and leak detection probes.

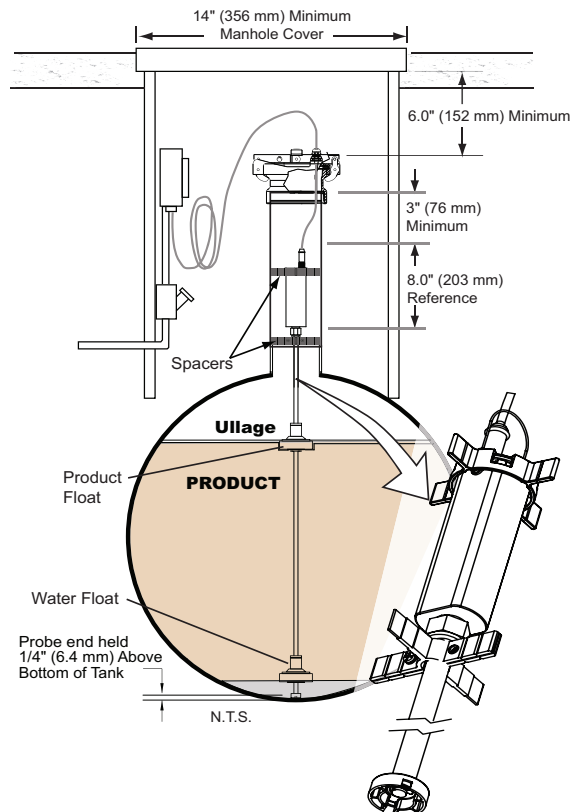

Figure 5: Bottom-Mount (I-Probe) Installed

## Above Riser Probes

For above-riser probes or ASTs, install the stainless steel TSP-K4AS riser adapter by tightening the lower swage lock fitting. (Figure 6)

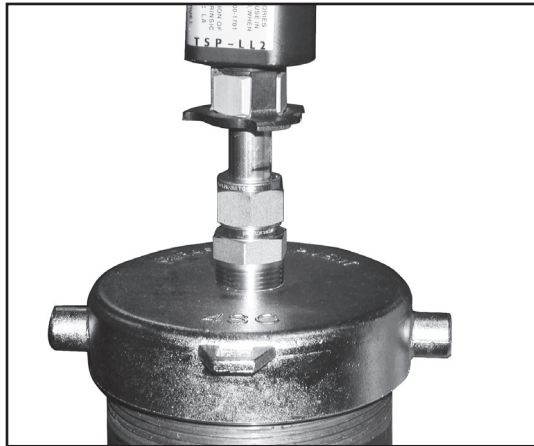

Figure 6: TSP-K4AS cap with Swage-Lock Fitting

Slide the floats onto the probe shaft after the probe has been inserted through the cap. Refer to manual 000-0113, TSP-K4AS with TSP-UVPK Installation Instructions for more information about mounting probes above the riser cap.

## Recording Probe Information:

### Gradient, Model # and Serial Number

For each tank, record the probe model number, serial number, and the probe gradient value (propagation constant). The TS-LL2 has two labels. The label included with the splice kit in the shipping tube contains the same information that is on the probe head label:

- Model (TSP-LL2-X)
- Serial #
- Gradient
- Probe length
- Max. Tank size
- Temperature sensor locations

For every installed probe, use indelible ink pen and mark the tank number where it was installed on each label. Save labels and make sure they are kept near the tank monitor for correct programming.

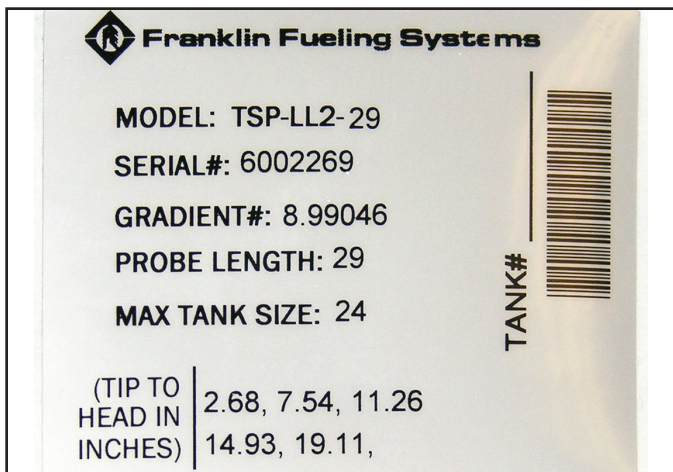

Figure 7: Sample Probe Information Label

## Probe Wiring

### LL2 Probe Splice Kit – Installation Instructions

The Liquid Level Probe Splice Kit includes 2 Electrical Connectors for installation inside the manhole junction box only. It is not intended for direct burial applications.

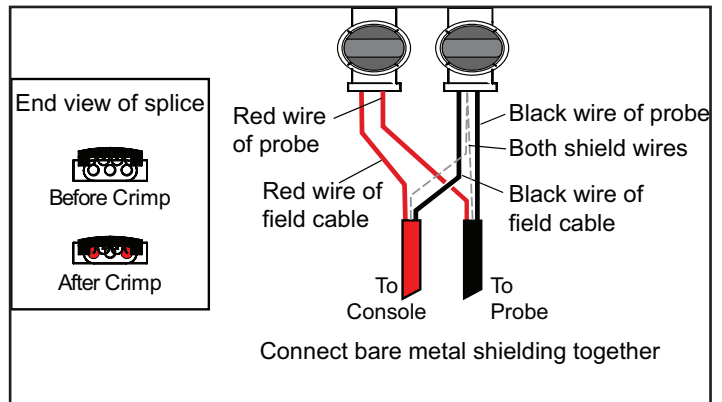

Figure 8: Splice Kit for Probe Wiring

1. Use 2 moisture-resistant connectors (provided) for each probe installation.
2. Insert 2 red *unstripped* wires into two separate openings of the first connector. Make sure the wires are fully inserted and seated at the end of the connector.

**Note: Belden cable # 89182 (for runs longer than 400 feet) has a yellow wire.** Wire the YEL wire to the + (RED) probe terminal inside the console.

3. Insert 2 black *unstripped* wires into two separate openings of the second connector and then insert the 2 shield wires into the remaining opening of the second connector. Make sure the wires are fully inserted and seated at the end of the connector.
4. The white wire inside the yellow probe cable is not used. Do not insert it into any connector. Cut the white wire back flush to the jacket of the yellow probe cable.
5. Use 8" slip-joint pliers and squeeze each connector together (position the plier's jaws on the connector perpendicular to the wires and drive the black cap down almost flush to the edge of the connector body).

For a supply of moisture-resistant splice connectors, Order:

- TSPKW30 for a pack of 30 splices.

For direct burial cable applications or for applications that don't use a junction box, order:

- TSP-DB1 for a single kit
- TSP-DB10 for 10 kits.

For information about direct-burial applications, refer to manual 000-1041, Direct Burial Cable Installation Instructions and 000-1133, Direct Burial Splice Kit Installation Guide.

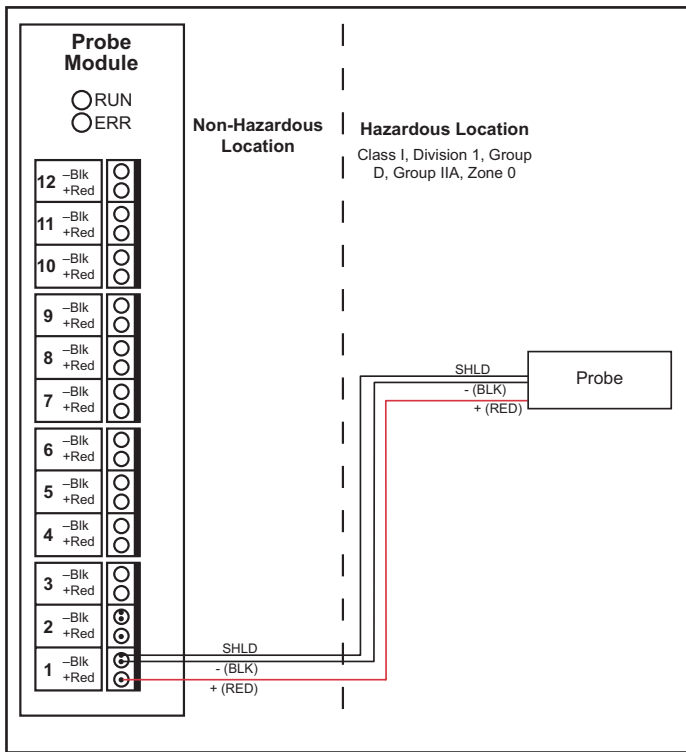

**Figure 9: Probe Module Wiring**

Refer to manual 000-2142, Fuel Management System Programming guide and 000-2150 Fuel Management System Installation guide for information about setting up the probe with the tank gauge.

For Colibri Tank Gauge Consoles, refer to manual 000-2153, Colibri Automatic tank Gauge Installation Guide, and 000-2155, Colibri Set-Up and Operation Guide. For Colibri manuals on the web, go to: [www.franklinfueling.com/colibri/literature.aspx](http://www.franklinfueling.com/colibri/literature.aspx)

## Tank Tilt/ Offset Calculations

If the data to calculate tank tilt is not known, or if the tank is not seriously tilted, then use +/- offsets to adjust the probe readings to match the stick readings at fill.

Figure 10 shows the tank tilt formula to use when the fill tube and probe are on opposite sides of the tank center-line. Figure 11 shows the formula to use when the fill tube and probe are on the same side of the tank center-line.

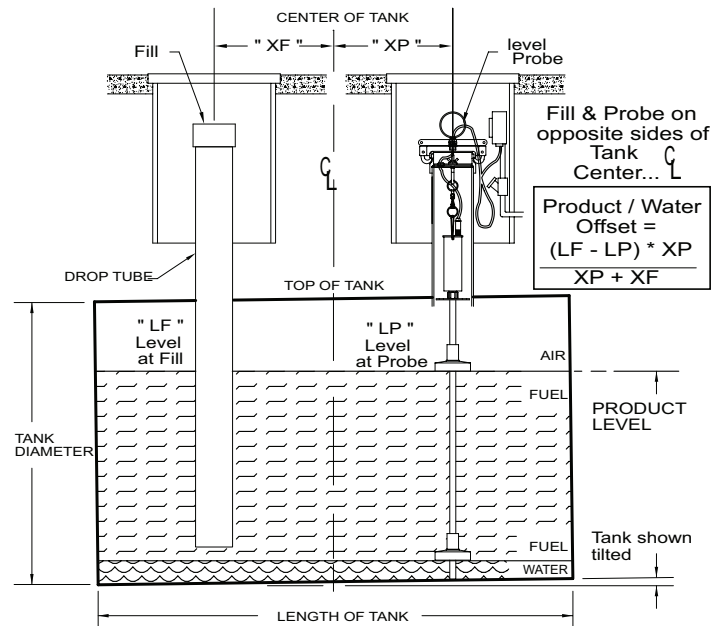

**Figure 10: Tank Tilt Calculation  
Probe and Fill on Opposite Sides**

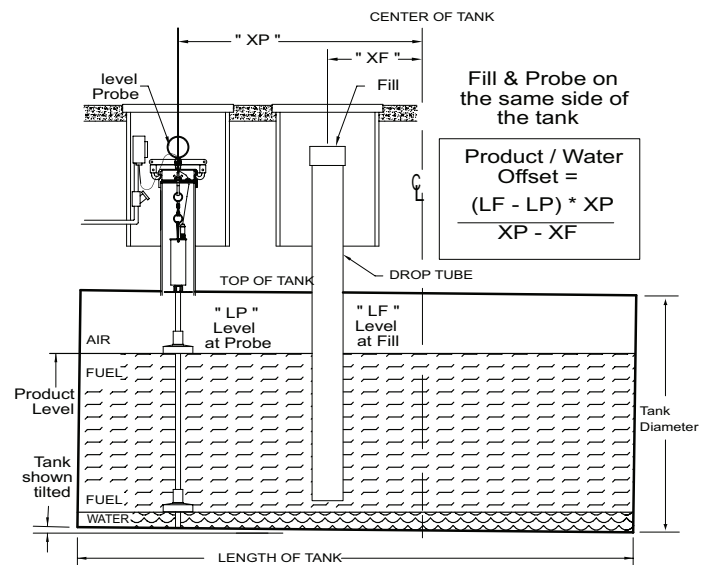

**Figure 11: Tank Tilt Calculation  
Probe and Fill on Same Side**

## Troubleshooting

When troubleshooting a probe problem, it is important not to presume any particular cause. Follow the steps outlined below to properly and quickly troubleshoot probes:

**Note:** Do not start troubleshooting by swapping probes. It may cause confusion in the process of identifying the problem.

### Float Missing:

1. Check programming of probe for correct number of floats
2. Look for active High water or Float Missing Alarms in the run status at the ATG.
3. If possible, have the technician stick the tank and compare the measurement with the level reported by the ATG.
4. Is the level correct? If not, is the ATG measuring in reverse (the lower the actual product level the higher it reads on the ATG)? Verify the Probe ratio is programmed correctly. If programming is correct it may be a probe issue, continue with the next steps.
5. Check the water level does the ATG list it as float missing? If it is listed as missing, it could be a probe issue, but again continue to troubleshoot.
6. Try to cycle power. If previously noted, check to see if High water alarm or float missing alarm changed from "ACTIVE" to "CLEARED". If they clear, again this could be a probe issue, but acknowledge and continue to troubleshoot.
7. After completing the above steps, replace the probe.

### No Probe, Probe Sync and Unstable Probe

(New Install or Replacement Probe)

1. Check Wiring. Ensure that the Red, Black and Shield wires are connected to the correct terminals to the ATG. There should be two connections in the junction box, (refer to figure 8).

(Probe Alarms on Multiple Channels or Only One Probe Connected)

2. Check Main Board Power Supply. There should be approximately 21 VDC loaded (probe connected) and 24 VDC unloaded across the Red and Black terminals of the probe channel in the ATG.
3. Check Field Wiring. Ensure that the voltage is getting to the probe by checking at the junction box splice or quick disconnect pigtail. With the pigtail end facing you, keyslot up, there should be 24 VDC across the two bottom pins. Test field wiring for a short or open.
4. Remake Splice. Cutback and remake the splice connection in the junction box using the approved seal pack and connectors.

(Quick Disconnect Pigtail)

5. Try a New Pigtail. If this probe has a quick disconnect pigtail, try replacing it.

6. Try another Probe Channel. Once the field wiring has been checked and the junction box connection remade, try moving the field wiring to another channel.
7. Connect the Probe Directly to the ATG. If possible, bring the probe inside and wire directly to the ATG. (If this probe has a quick disconnect pigtail then the white wire should be connected to shield or ground).

Listed below are additional steps for troubleshooting the probe. For missing float or incorrect level problems, consider the following actions:

- Pull probe from tank and manually raise and lower floats. Does the ATG accurately report the change in level?
- Are the right number of floats installed on the probe (verify number of floats programming)
- Is float too close to the end of the probe? (Was tank overfilled or is the float stuck in riser)? If float is too close to the probe head a float missing alarm will occur.
- Is there debris on the magnets? If so, clean debris from magnet and check operation of ATG.
- Are the magnets cracked or broken? If so replace float
- Are the floats installed correctly? Product float on top, closest to the probe head. Product float will have a white collar. Water floats have colored collars (Red for use in gasoline, blue for use in diesel)
- Is the probe shaft clean? If dirty use an abrasive pad to clean the probe shaft.
- Check that wire connections from probe cable to field wiring are good and dry.
- Are the floats compatible with the probe? LL and LL2 floats are NOT interchangeable.

Page Intentionally blank

**INCON**<sup>®</sup>



**Franklin Fueling Systems**

[www.franklinfueling.com](http://www.franklinfueling.com)

3760 Marsh Road • Madison, WI 53718, U.S.A.

Tel: +1 608 838 8786 • Fax: +1 608 838 6433

Tel: USA & Canada 1 800 225 9787 • Tel: México 001 800 738 7610

**Franklin Fueling Systems GmbH**

Rudolf-Diesel-Strasse 20 • 54516 Wittlich, GERMANY

Tel: +49-6571-105-380 • Fax: +49-6571-105-510