



S940

Sensor Alarm Console

Installation and Operation Guide

Notice

INCON reserves the right to change this document and specifications at any time without notice. INCON makes no expressed or implied warranty with regard to the contents of this manual. INCON assumes no liability for errors or omissions, or for any damages, direct or consequential, that may result from the use of this document or the equipment that it describes.

Trademarks

INCON®, TS-5 Series®, System Sentinel®, SCALD®, Brite®, BriteBox®, BriteBus®, and BriteSensors® are registered trademarks of Intelligent Controls. All brand and product names are trademarks or registered trademarks of their respective companies.

Inspection of Materials

Visually inspect all components for defects or damage prior to installation. If any defect or damage is found, do not use the product and contact INCON for further assistance.

Return Shipping Charges

INCON will not accept shipments of returned products without a Return Material Authorization (RMA) number. RMAs are obtained by contacting INCON's Technical Service Division — NO RMAs will be given without the unit's serial number(s). Returned material remains the property of the buyer until replaced or repaired.

Under Warranty

INCON will pay all freight and insurance charges for all "Under-Warranty" RMAs.

Non-Warranty

It is the buyer's responsibility to prepay all freight and insurance charges for "Non-Warranty" RMAs.

Refer to the Warranty document FFS-0079.

Contacting Franklin Fueling Systems (FFS)

Please feel free to contact us by mail at:

Franklin Fueling Systems
3760 Marsh Rd.
Madison, WI 53718 USA

Or contact us by phone, fax or e-mail:

Tel: 1 608 838 8786

Fax: 1 608 838 6433

Tel: US & Canada 1 800 225 9787

Tel: México 001 800 738 7610

Tel: Europa +49 6571 105 380

E-mail: sales@franklinfueling.com

techserve@franklinfueling.com

Office Hours: 8am to 5pm CST - Monday through Friday

Please visit our web site at www.franklinfueling.com

Contents

Important Safety Messages	1
Introduction	2
Product Description.....	2
Installation.....	2
Operation.....	3
Programming.....	3
Control Drawing.....	4

Important Safety Messages

INCON equipment is designed to be installed in association with volatile hydrocarbon liquids such as gasoline and diesel fuel. Installing or working on this equipment means working in an environment in which these highly flammable liquids may be present. Working in such a hazardous environment presents a risk of severe injury or death if these instructions and standard industry practices are not followed. Read and follow all instructions thoroughly before installing or working on this, or any other related, equipment.

As you read this guide, please be aware of the following symbols and their meanings:

Warning  This symbol identifies a warning. A warning sign will appear in the text of this document when a potentially hazardous situation may arise if the instructions that follow are not adhered to closely. A potentially hazardous situation may involve the possibility of severe bodily harm or even death.

Caution  This is a caution symbol. A caution sign will appear in the text of this document when a potentially hazardous environmental situation may arise if the instructions that follow are not adhered to closely. A potentially hazardous environmental situation may involve the leakage of fuel from equipment that could severely harm the environment.

Danger  This symbol identifies an electrical danger. An electrical danger sign will appear in the text of this document when a potentially hazardous situation involving large amounts of electricity may arise if the instructions that follow are not adhered to closely. A potentially hazardous situation may involve the possibility of electrocution, severe bodily harm, or even death.

Warning  **Follow all applicable codes governing the installation and servicing of this product and the entire system. Always lock out and tag electrical circuit breakers while installing or servicing this equipment and any related equipment. A potentially lethal electrical shock hazard and the possibility of an explosion or fire from a spark can result if the electrical circuit breakers are accidentally turned on during installation or servicing.**

Warning  **Follow all federal, state and local laws governing the installation of this product and its associated systems. When no other regulations apply, follow NFPA codes 30, 30A and 70 from the National Fire Protection Association. Failure to follow these codes could result in severe injury, death, serious property damage and/or environmental contamination.**

Warning  **When the Alarm Console is used to monitor tanks containing gasoline or other flammable substances, you may create an explosion hazard if you do not carefully follow the requirements in this manual.**

Warning  **All wiring must enter the console's enclosure through the designated knockouts. An explosion hazard may result if other openings are used. All wiring from sensors to the console must be run in conduit separate from all other wiring. Failure to do so will create an explosion hazard.**

Introduction

This manual contains installation instructions for the INCON S940 Alarm Console.

Please carefully read this entire manual. Failure to follow the instructions in this manual may result in faulty operation, equipment damage, injury or death.

This equipment should only be serviced by an INCON-certified technician.

Product Description

The 4-channel Alarm console is a stand-alone unit that monitors 4 intrinsically safe sensor contact closures and provides a visual and audible alarm should one of the normally closed contacts become open.

The unit also provides 2 SPDT dry relay contacts that can be set to activate upon an alarm condition.

The S940 is typically used to monitor sumps, overflow or spill-containment areas.

Specifications

Console Specifications	
Input Line Voltage:	100-240 VAC +/- 10%, 50/60 Hz, 15W max
Input power fuse rating	1A, 250 VAC, time delay
Operating temperature	-25° C (-13° F) to +60° C (+140° F)
Enclosure	NEMA 4, indoor / outdoor * (Non-hazardous locations only)
Dimensions	6" X 6" x 4" (15.2 cm x 15.2 cm x 10.2 cm)
Relay contact rating	10A, 240VAC maximum (non-fused)
Conduits	Two NPT, 1/2"
Intrinsic safety	Class I, Div 1, Group D

* For outdoor use application, listed Type 4X conduit hubs must be used.

Note: For power supply connection, use wires rated at least 90 °C (194 °F).

Installation

Mounting

To mount the unit to the wall, first attach the included mounting tabs to the box (figure 1) and then attach it to the wall.

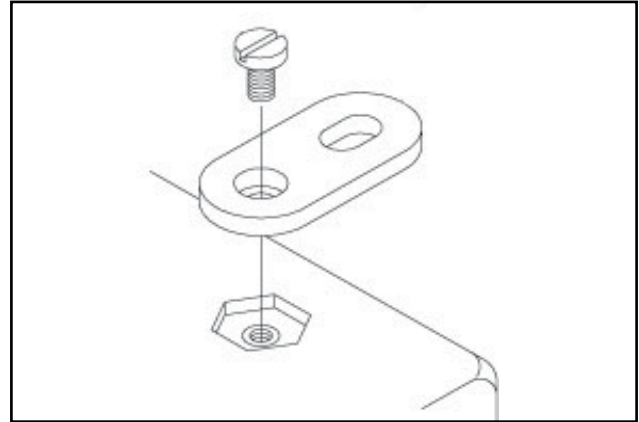

Figure 1: Box Mounting Tab

Power Supply Wiring

NOTE: The S940 Alarm Console is set to operate with between 100 to 240 VAC, 50/60 Hz. No setup is required.

The Alarm Console must be connected to a dedicated circuit breaker, at the service panel, not exceeding 15 Amps.

To access wiring and programming, remove the 4 corner phillips-head screws on the faceplate and pull the faceplate straight out by holding the two faceplate knobs.



Electrical Hazard! Disconnect main power to the console before removing the faceplate.

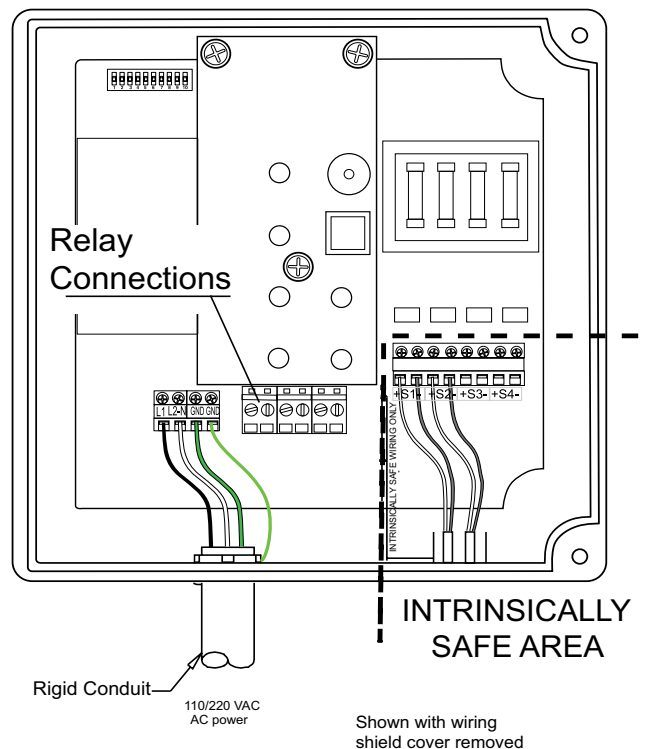



Figure 2: Installation Wiring

1. Connect the right ground terminal to the earth ground bus at the service panel. Use #14 AWG copper conductor wire.
2. Connect the left ground terminal to the metal rigid conduit used to feed service panel wiring with #14 AWG copper conductor wire.
3. Connect power wires to the appropriate terminals on the power supply terminal strip: Ground, Line, Neutral, Earth Ground.

Sensor Wiring

Warning  **All sensor wiring is to be intrinsically safe and run into the right side of the wiring bay and be fully contained within the intrinsically safe wiring compartment. When replacing the faceplate, make sure no wires are pinched under the faceplate compartment divider.**

1. Remove the wire jumper from each contact input that you plan to use.
2. Wire each normally closed sensor to the appropriate terminals.

Note: Only the following INCON sensors can be used with the S940 console:

- TSP-ULS Universal Liquid Sensor
- TSP-HLS High Level Sensor
- TSP-UHS Universal Hydrostatic Sensor
- TSP-HFS Horizontal Float Switch Sensor

Using other sensors will violate the warranty.

Note: Sensors must be 3rd party or simple apparatus.

Relay Wiring

1. Wire the device to the relay terminal strip in accordance with the instructions furnished by the manufacturer of the device.
2. Observe the relays for terminal layout and voltage/current limits (10A @ 240 VAC).

Operation

When the contact input senses an open condition the corresponding red alarm LED will light and the annunciator will sound, and if a relay has been programmed it will change states.

The annunciator can be silenced by pressing the silence/test button. It will continue to sound until this button is pressed, even if the actual alarm condition clears.

The alarm LED (and relay if programmed) will turn off when the alarm condition clears.

If there is no alarm condition, and the alarm reset button is pressed, the audible alarm will sound and the relays will activate. Press again to silence and turn off the relays.

Programming

Relay Configuration

Choose which output relay will be triggered by each sensor and activate them by moving the appropriate “Output Relays” DIP switch to the “on” position. The DIP selector switch is located in the wiring bay.

DIP Switch	Relay	Effect
1		Sensor 1
2	1	Sensor 2
3		Sensor 3
4		Sensor 4
5		Sensor 1
6	2	Sensor 2
7		Sensor 3
8		Sensor 4
9	1	Steady or Single Pulse Alarm
10	2	Steady or Single Pulse Alarm

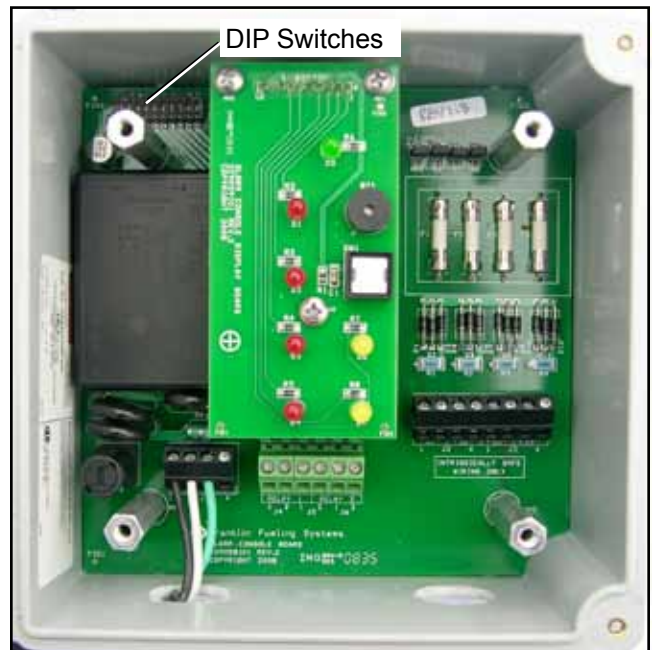
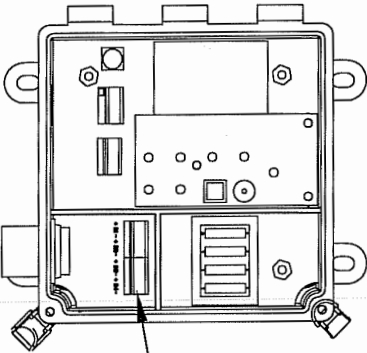

Figure 3: DIP Switch Location

Control Drawing

- NOTES:
- 1) THE S940 SENSOR ALARM CONSOLE SHALL NOT BE CONNECTED TO ANY EQUIPMENT WHICH USES OR GENERATES GREATER THAN 250V.
 - 2) EACH GROUND TERMINAL SHALL BE CONNECTED TO A SUITABLE SYSTEM EARTH GROUND. THE DC RESISTANCE BETWEEN GROUND TERMINALS AND EARTH GROUND SHALL BE LESS THAN 1 OHM.
 - 3) THE S940 SENSOR ALARM CONSOLE WIRING SHALL BE INSTALLED IN ACCORDANCE WITH THE APPLICABLE NATIONAL OR LOCAL CODES. IN CONDUCTORS OF DIFFERENT INTRINSICALLY SAFE CIRCUITS RUN IN THE SAME CABLE/CONDUIT MUST HAVE AT LEAST 0.25mm OF INSULATION.
 - 4) CAPACITANCE AND INDUCTANCE OF THE FIELD WIRING FROM THE INTRINSICALLY SAFE EQUIPMENT TO THE BARRIER SHOULD BE CALCULATED AND SHOULD BE INCLUDED IN THE SYSTEM CALCULATIONS AS SHOWN IN TABLE 1
 - 5) WIRING, CABLING AND SEALS MUST BE INSTALLED IN ACCORDANCE WITH THE NEC, CEC OR OTHER APPLICABLE NATIONAL OR LOCAL CODES.



NON-INTRINSICALLY SAFE COMPARTMENT

INTRINSICALLY SAFE COMPARTMENT

NON HAZARDOUS LOCATION
S940 SENSOR ALARM CONSOLE
ASSOCIATED APPARATUS

TABLE 2 - ENTITY PARAMETERS

TERMINAL	Uo/Voc	Io/Isc	Co/Co	Lo/La	Po
+(WHT), -(BLK)	6.51 Vdc	72.3 MA	500 uF	27.2 mH	0.118W

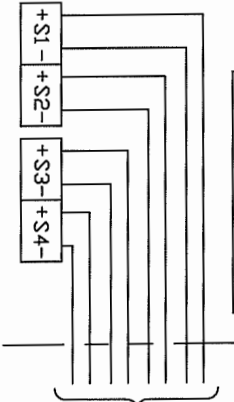

TO INTRINSICALLY SAFE APPARATUS

TABLE 1

Uo (Voc) </= Uo (Vmax)
Io (Isc) </= Io (Imax)
Po </= Pi (Pmax)
Co (Co) >/= Ci + Ccable
Lo (La) >/= Li + Lcable

HAZARDOUS LOCATION
CLASS I, DIV. I, GROUP D

- 6) SENSOR WIRING TO THE S940 MUST COMPLY WITH LOCAL, STATE OR NATIONAL CODE.
- 7) ONLY USE CRIMP TYPE CONNECTORS FOR ELECTRICAL CONNECTIONS.
- 8) SEAL ALL FIELD WIRING CONNECTIONS FROM MOISTURE WITH EPOXY SEAL - PACKS.
- 9) SEE INSTALLATION MANUAL FOR MORE DETAIL.
- 10) THE GENERAL CONTRACTOR MUST SUPPLY THE SPECIFIED WIRE, CONDUITS AND ALL ELECTRICAL ACCESSORIES.
- 11) THE ENTITY CONCEPT ALLOWS THE USER TO IDENTIFY ACCEPTABLE COMBINATIONS OF INTRINSICALLY SAFE APPARATUS AND ASSOCIATED APPARATUS THAT HAVE NOT BEEN EXAMINED AS A SYSTEM. EACH APPARATUS IS EXAMINED SEPARATELY BY A NATIONALLY RECOGNIZED TEST LABORATORY (NRTL) OR NOTIFIED BODY AND ASSIGNED A SET OF PARAMETERS CALLED ENTITY PARAMETERS. THE ENTITY PARAMETERS CAN BE FOUND IN TABLE 2. TO DETERMINE THE Vmax (Uo), Imax (Io), Ci AND Li VALUES THE CONTROL DRAWING FOR THE INTRINSICALLY SAFE APPARATUS AND ASSOCIATED APPARATUS MUST COMPLY WITH TABLE 1. (SEE NOTE 4).
- 12) THE OUTPUT CURRENT OF THIS ASSOCIATED APPARATUS IS LIMITED BY A RESISTOR SUCH THAT THE VOLTAGE-CURRENT PLOT IS A STRAIGHT LINE DRAWN BETWEEN OPEN-CIRCUIT VOLTAGE AND SHORT-CIRCUIT CURRENT.
- 13) THIS ASSOCIATED APPARATUS HAS NOT BEEN EVALUATED FOR USE IN COMBINATION WITH ANOTHER ASSOCIATED APPARATUS.

ATEX Certified Product
~Schedule Drawing~
ATTENTION: No modification permitted without approval of the Notified Body

REVISIONS

REV	NO	DESCRIPTION	DATE	APPROVED
B		0.118W WAS 0.118W	01/19/09	402237
C		CHNG PER UL REQUEST REF ECN	3/16/09	402378
D		CHNG PER UL REQUEST REF ECN	4/14/09	402454

UNLESS OTHERWISE SPECIFIED:
DIMENSIONS ARE IN INCHES
TOLERANCES

DECIMALS: .XX ± .01
ANGULAR: ± 0°30'
FRACTIONAL: ± 1/64

THIRD ANGLE

DRAWN: *Billie* DATE: 12/4/08
CHECKED: APPR: APPR

INTELLIGENT CONTROLS, INC.

CONTROL DRAWING
S940 ALARM CONSOLE

SCALE: 1:1

DWG NO. 000-1734

SHEET 1 OF 1

REV D

THE INFORMATION CONTAINED IS THE PROPERTY OF INTELLIGENT CONTROLS, INC. AND IS NOT TO BE COPIED, USED OR REPRODUCED WITHOUT THE PERMISSION OF INTELLIGENT CONTROLS, INC.

INCON[®]



Franklin Fueling Systems

www.franklinfueling.com

3760 Marsh Road • Madison, WI 53718, U.S.A.

Tel: +1 608 838 8786 • Fax: +1 608 838 6433

Tel: USA & Canada 1 800 225 9787 • Tel: México 001 800 738 7610

Franklin Fueling Systems GmbH

Rudolf-Diesel-Strasse 20 • 54516 Wittlich, GERMANY

Tel: +49-6571-105-380 • Fax: +49-6571-105-510