

TS-1001, BulkStik, AutoStik (except AutoStik II 8Ch)  
Ribbon Cable (P/N 600-0077 & 600-0032):

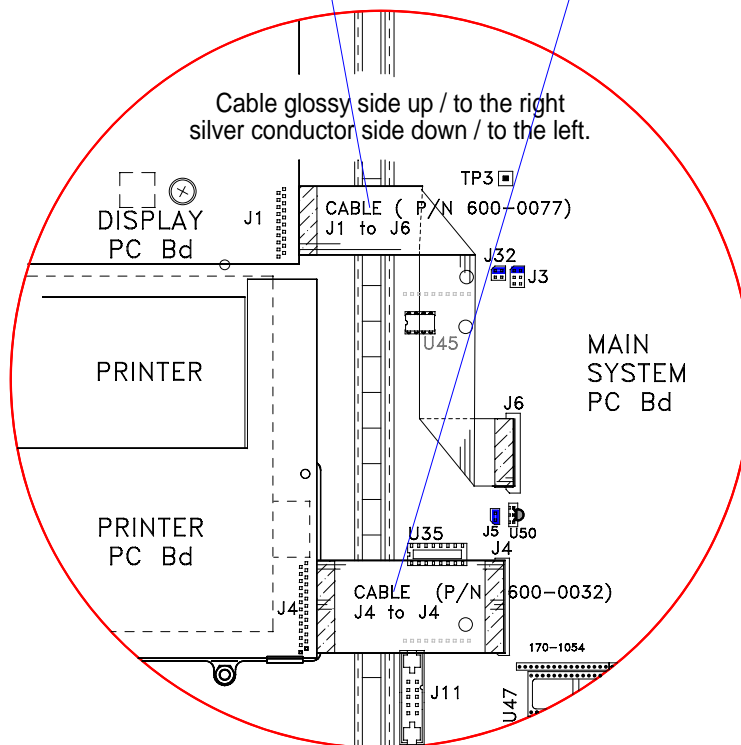

**Diagram: 1**

**Removal** (with all Tank Gauge power **OFF**):

- Remove ribbon cable by pulling it straight out → of its connector (see above).  
NOTE: The 26 conductor printer cable is P/N 600-0032 and the 20 conductor Display and Keypad cable is P/N 600-0077.

**Installation** (with all Tank Gauge power **OFF**):

- Install the cables back into the appropriate connector **gloss side up or to the right** (silver conductor side down or to the left). Do this by grasping the flat ribbon cable near the end and pushing it straight into its connector.

