



Discriminating Magnetostrictive Sensor

Model TSP-DMS

Installation Manual



Warning INCON equipment is designed to be installed in association with volatile hydrocarbon liquids such as gasoline and diesel fuel. Installing or working on this equipment means working in an environment in which these highly flammable liquids may be present. Working in such a hazardous environment presents a risk of severe injury or death if these instructions and standard industry practices are not followed. Read and follow all instructions thoroughly before installing or working on this, or any other related, equipment.

Note: The TSP-DMS is for connection to INCON T5 series consoles only.

The Discriminating Magnetostrictive Sensor TSP-DMS is designed to detect water or fuel in a sump, and give notification through the fuel management console. The sensor also has anti-tamper capability that will notify if it is lifted from its installed position.

Magnetostrictive Sensor Installation

The TSP-DMS come supplied with a model 283-0205 Unistrut 2" pipe clamp assembly. If the sump has a Unistrut already installed, mount the 2" clamp to the Unistrut and slide the DMS sensor so the wire is at the top, and the bottom is tight against the bottom of the sump.

If the sensor is mounted in a sump that does not have a Unistrut channel installed, order part number TSP-KS, and follow installation instructions. Make sure that the sensor is touching the bottom of the sump before and after tightening the mounting bracket.

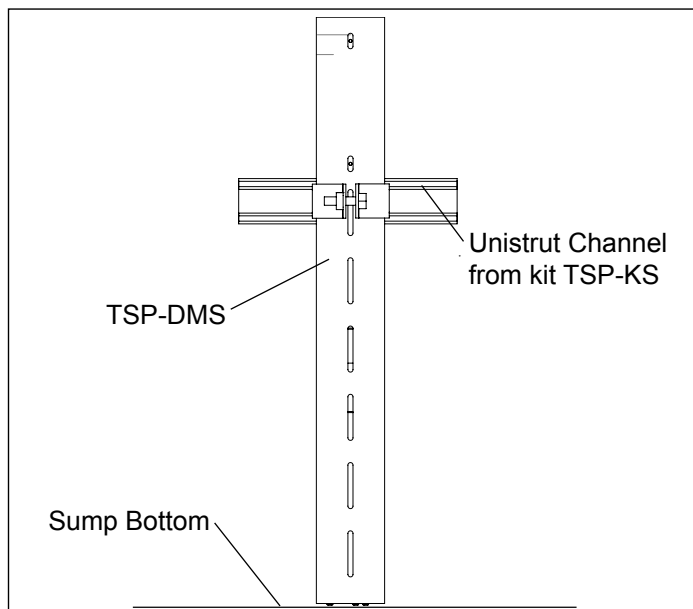

Figure 1. TSP-DMS Sensor Installed

TSP-DMS Wiring

The sensor cable wiring must be:

- Shielded twisted pair instrumentation cable
- Minimum 18 AWG
- Gas and oil resistant jacket
- Maximum length 1500 ft.

Franklin Fueling Systems recommends the use of the following cables. Some are available for sale as indicated.

Cable Type	O.D.
Belden No. 87760	0.12" (3 mm)
* Belden No. 87761	0.12" (3 mm)
Belden No. 88761	0.12" (3 mm)
* Belden No. 89182	0.31" (7.9 mm)

* These cables can be ordered from INCON.

Use only cable as specified or equivalent to the above. Do NOT exceed cable lengths of 1500 feet.

Table 1: Sensor Cables

WARNING: Use of sub-standard cables, or exceeding maximum cable lengths may result in faulty operation, can create an explosion hazard, and WILL void the warranty.

Cable Color Code

Use the following color code for the sensor wiring:

RED or YELLOW WIRE = + (Signal)

BLACK WIRE = - (Signal Ground)

BARE = SHLD (Shield)

Label Cables

Label all sensor cables within the weatherproof pull box, and at the console with the Tank/Sensor number.

Conduit

The above-listed wiring is for use when run in Rigid Metal Conduit. If local codes allow use of nonmetallic (PVC) conduit, Alpha Wire #58411 (INCON #600-0062) must be used.

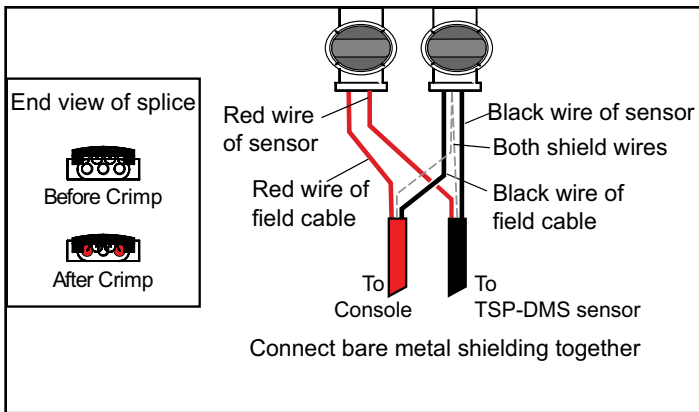

Figure 2: Model TSP-DMS — Cable Wire Splicing

Splice the sensor cables together at the weatherproof junction box located in the manhole as shown in Figure 2.

Black wires from sensor and console are spliced together with the shield (bare) from both.

Red wires from sensor and console are spliced together.

If a white wire is present on the sensor cable, cut it back.

Use the No-Strip Electrical connectors supplied in the installation kit to make all connections.

Note: Do not use wire nuts to make sensor connections.

Use the crimp splice connectors supplied with the TSP-DMS, or equivalent, only. Failure to use the appropriate crimp-splice connectors will result in faulty operation and will void the warranty.

Console — DMS Sensor Wiring Connections

The wiring should connect to the probe module. The probe module may also have wiring from the vapor flow meter and other probes.

Remove 1-1/2" (38 mm) of jacket from each sensor cable, and strip off 3/16" (5 mm) of insulation from the end of each conductor.

In the console, start wiring from channel 1 on probe module and work up from there. Wire the three wires of the cable to the PROBE interface terminal set (channel) as described below:

- 1) Connect the black wire to the minus – (BLK) terminal.
- 2) Connect the red (or yellow) wire to the plus + (RED) terminal.
- 3) Connect the cable shield to the same - (BLK) terminal as the black wire.

Repeat this wiring scheme until all sensors are wired to the probe input channel terminals (+, –/SHLD). A sensor or probe can be wired to any input probe channel and will operate normally after it is setup/programmed correctly.

Note: The sensor must be touching the bottom prior to the learn process.

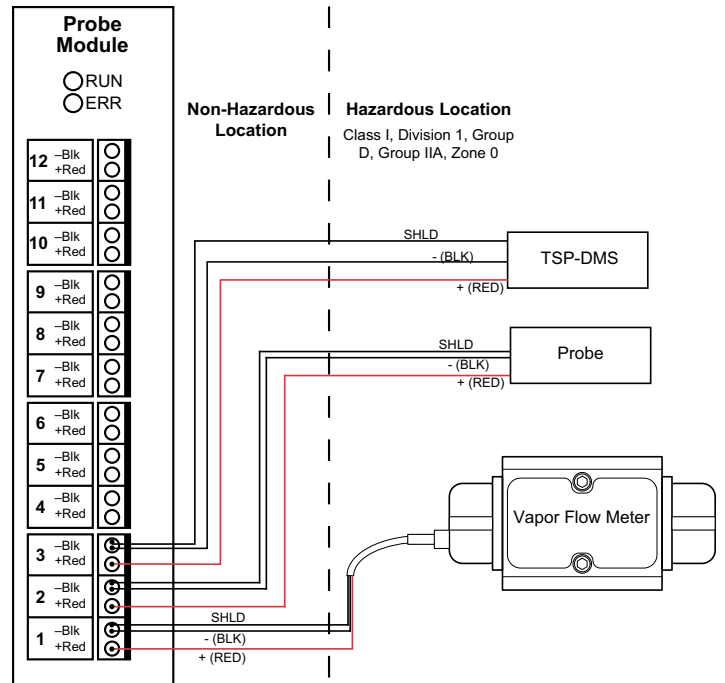



Figure 3: Sensor Connection to Console

Note: Avoid wiring errors by using consistent color codes when making sensor cable connections. Always use the Red (or yellow) wire for the + signal. Always use the Black wire for – signal ground. And always use the bare wire as the shield.

Note: Make sure that all conduits, conduit fittings, junction box fittings and hole plug threads are waterproofed with pipe-dope. Wet wiring will result in faulty operation.

Caution  **Make sure that the sensor cable is wired correctly. Reversing the plus and minus terminals can damage the Intrinsically Safe circuits.**

Warning  **Only one sensor should be connected per channel. Connecting multiple sensors to a single cable or channel in the FMS console may cause damage to the unit and may create an explosion hazard, and will result in improper system operation.**

Franklin Fueling Systems
 www.franklinfueling.com

3760 Marsh Road • Madison, WI 53718, U.S.A.
 Tel: +1 608 838 8786 • Fax: +1 608 838 6433
 Tel: USA & Canada 1 800 225 9787 • Tel: México 001 800 738 7610

Franklin Fueling Systems GmbH
 Rudolf-Diesel-Strasse 20 • 54516 Wittlich, GERMANY
 Tel: +49-6571-105-380 • Fax: +49-6571-105-510