

**PowerSentinel™
Model PS-3Y480****Power Conditioning Unit
Installation Guide****WARNING:**

1. Opening the PS-3Y480 unit without prior permission from INCON (Intelligent Controls, Inc.) will void the warranty coverage. Contact INCON 1-(800)-984-6266 if you have any questions.
2. Apply this unit only to 277/480VAC, 50/60Hz, 3-phase, 4-wire, Wye configuration load only.
3. The unit must be mounted vertically, in a dry location, using the four mounting holes.
4. The unit must be installed by a licensed electrician and in compliance with local electrical codes.
5. **IMPORTANT: THIS UNIT MUST BE CONNECTED DIRECTLY TO A DEDICATED CIRCUIT BREAKER. DO NOT, UNDER ANY CIRCUMSTANCES, HARD-WIRE INSTALL WITHOUT A DEDICATED BREAKER.**

YOU WILL NEED:

1. A dedicated, 3 pole, 50 Amp circuit breaker – intended for the existing panel
2. Appropriate tools, including conduit
3. A licensed electrician for installation

MOUNTING THE Power Sentinel:

1. Inspect the exterior of the unit to ensure that it has not been damaged in transit. Ensure that the front label/overlay is still intact, that the warranty seals are intact, and that the cable protruding from the unit has not been damaged.
2. Locate and mount the unit on a clean, dry wall near the power panel. For optimum surge protection, locate the unit within two feet of the power panel. **DO NOT UNDER ANY CONDITIONS SPLICE NEW CABLE ONTO THE UNIT, OR OPEN THE UNIT, TO EXTEND THE LENGTH OF THE CABLE PROVIDED.** When mounted, the three phase indicator lights should be horizontal and visible.
3. Run conduit (according to code) between the conduit connector on the PowerSentinel and the power panel, and feed the connection cables through the conduit into the power panel.

INSTALLATION PROCEDURES:

1. De-energize the power panel prior to connection of the PowerSentinel unit.
2. Install the circuit breaker in the power panel.
3. Connect the cables (orange, yellow, brown) to the circuit breaker, the ground cable (green) to the ground bus, and the neutral cable (white) to the neutral bus, as shown in the diagram below.

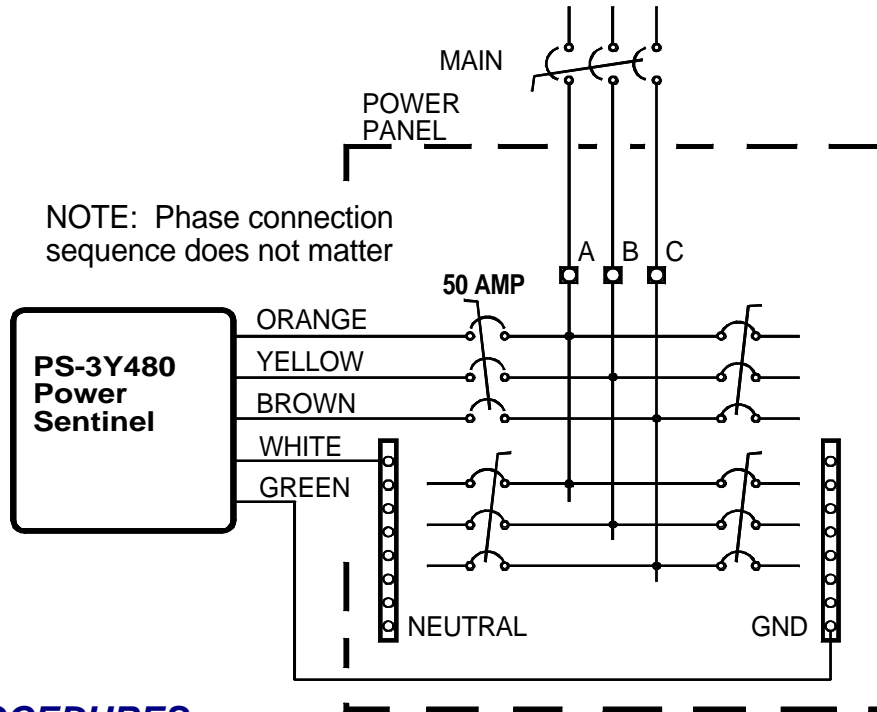

TEST PROCEDURES:

1. Energize the power panel.
2. Energize the primary inductive load(s) on the panel.
3. Close the circuit breaker leading to the PS-3Y480 — PowerSentinel unit.
4. Check to see if all lights are on:
 YES – Proceed to next step.
 NO – De-energize the unit and check if cables are connected correctly. Check the ground cable connection. If problem persists, call INCON for technical support.
5. Check if all line currents are 37A (+/- 2A); if not, call INCON for technical support.
6. Put these instructions near the unit, for future use.

Fill-in and Mail the Warranty Registration Card within 10 days after installation

