



TSP-ULS (Standard Sensor)

Universal Liquid Sensor

Installation Instructions

CAUTION

SENSITIVE INSTRUMENT

When installing this sensor, carefully lower it into position and DO NOT DROP it into the sump or tank

Franklin Fueling Systems • 3760 Marsh Rd. • Madison, WI 53718 USA

Tel: +1 608 838 8786 • 800 225 9787 • Fax: +1 608 838 6433 • www.franklinfueling.com

Overview

The TSP-ULS is a Standard sensor that is used to detect the presence of a liquid in the normally dry Class 1, Division 1, Group D Hazardous Areas of: sumps, dispenser-pans, and interstitial areas of double-wall steel storage tanks.

The sensor is supplied with electrical connectors, 25 feet of cable, and a cord-grip fitting (see diagrams). The TSP-ULS uses magnetic-float/reed-switch technology (the sensor must be suspended vertically (See Figure 1) so the float can rise freely with the level of a liquid).

When the float rises more than 1/2 of an inch, the magnetically sensitive reed switch will open (see internal float in Figure 1). An open circuit is recognized as an alarm-condition at the intrinsically safe (I.S) leak detection circuits of the FFS (Franklin Fueling Systems) ATG console.

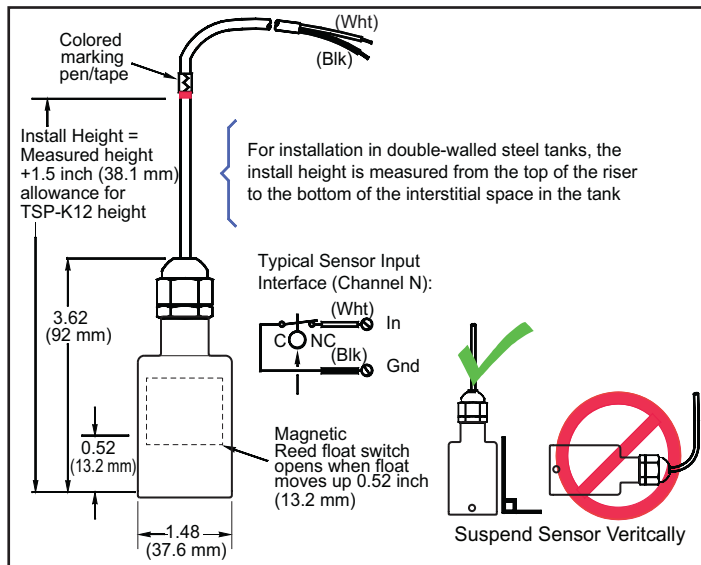

Figure 1: TSP-ULS Dimensions

Materials Required

- Optional – TSP-DB1 Epoxy Seal kit for no-strip electrical connectors – recommended for sites: within flood zones, high groundwater tables, with poor drainage, or when junction boxes are not used.
- 1/2 or 3/4 inch NPT (National Pipe Thread, tapered), Rigid Metal Conduit (RMC) or nonmetallic (PVC) conduit if allowed by local codes.
- EYS Seal fittings and Epoxy to fill the fitting after operational testing is completed.
- Weatherproof junction Box, gasket, and cover, plus a 3/4 to 1/2 inch NPT reducing bushing if 1/2 inch RMC is used – see the ATG Installation Guide for recommended electrical Junction Boxes.
- Wire: THHN, TFFN or THWN, 18 AWG, White & Black, or Alpha Cable # 58411, 0.114 O.D. – 1,500 feet (457 meters) max. length. Alpha cable #58411 must be use with nonmetallic conduit.
- Slip joint pliers to seat the no-strip, self-sealing wire connectors – connectors are supplied with the sensor.
- UL Classified Thread Sealant or pipe dope.

- *TSP-K12 Riser Cap for 2-inch riser pipes, includes a pre-installed 1/2 inch NPT compression gland (cord grip) fitting. Other riser caps are available for different riser pipe sizes – consult your factory rep.
- * Riser pipe – 2 inch diameter (OD), threaded at one end (NPT-14) with all rough edges removed/deburred from the inner edges.

* = Needed for installation in UST interstitial areas (Figure 2)

Installation Sequence

1. Install Riser Pipe, Manhole.
2. Install conduit, EYS fittings, and weatherproof junction box.
3. Shut off power.



ELECTRICAL DANGER Avoid electrical shock hazards: ensure all power going to the ATG console is turned off, tagged, and locked-out at the power panel before doing any maintenance or installation work at the ATG console.

4. Interstitial installation – see Figure 1 & 2, measure the INSTALL HEIGHT needed and add 1.5 inches = total height. Mark the total height on the sensor cable as shown in Figure 1, pull the cable through the TSP-K12 Riser Cap and cord-grip until the mark shows at the top of the cord grip fitting. Tighten the fitting and lower the sensor into the interstitial area of the tank as shown in Figure 2.

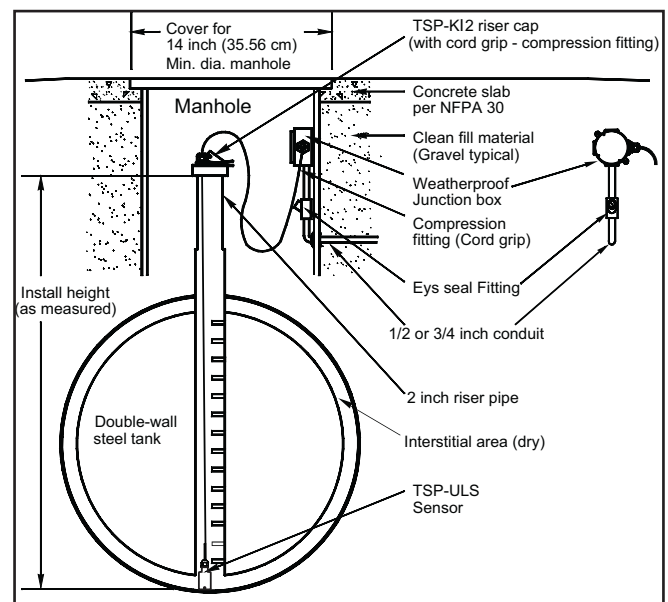

Figure 2: Installation in Double-Walled Steel Tanks

5. Pull the sensor cable through the cord grip fitting at the junction box (also see Figure 3 for installation within a sump) and tighten all remaining cord-grip fittings. Trim wire/cables to a 6 or 8 inch (15 or 20 cm) service-loop, and splice the sensor and console cable/wires together as shown in Figure 4.

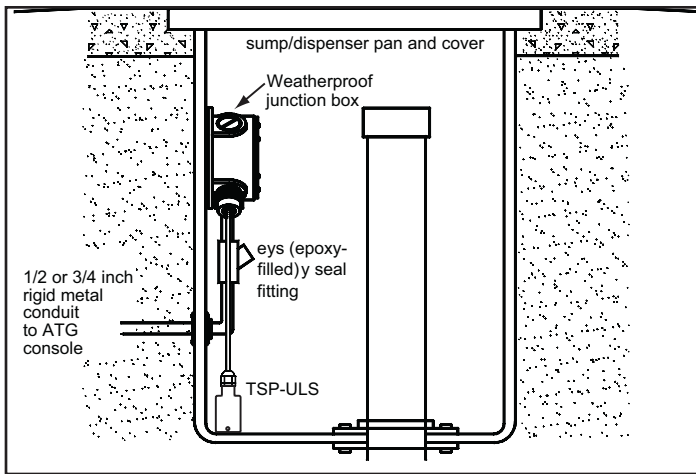



Figure 3: Installation in Sumps/Dispenser Pans

6. Power up Console for next step.
7. Test sensor (verify that an alarm is produced at ATG console), if it does produce an alarm, seal EYS seal fittings and electrical connectors with epoxy.
8. Turn off power again if other devices are to be installed (Repeat Step 3).
9. Reinstall all safety covers and guards, junction box gasket and covers – use pipe-dope to seal all fitting threads.
10. Install the manhole cover.
11. Record the location where the sensor was installed on the chart on the last page of these instructions. This information will be needed when programming the ATG.
12. Turn on power and program the ATG – Ref: all relating to Sensors in the Setup/Programming Guide manual.

General Installation Notes

* Steel double-walled tanks are equipped with a pipe that allows direct access to the bottom of the interstitial (annular) space. When installing a riser pipe in a steel tank, codes may require a non-conductive isolation bushing be installed between the tank and riser pipe.

Warning  **It is the installer's responsibility to comply with all applicable federal, state and local codes. Failure to do so may create an Environmental Hazard.**

* Fill the bottom of the manhole with crushed stone to facilitate drainage when the TSP-ULS is installed in the interstitial space of a steel tank. Do not cover the top of the riser with fill material, it must remain accessible for service and for sensor installation.

Plan your conduit routing. Dig trenches as necessary to install rigid threaded conduit (RMC) from each manhole junction box to the Intrinsically Safe (I.S.) knockouts at the ATG console. The conduit may enter the manhole either from its bottom or through its side. A junction box inside of the building as a pull box to combine several sensor cables. If this is done, then only one I.S. conduit knockout will be used.

Warning 

Conduits must have EYS seal fittings installed in accordance with NFPA 70 (National Electric Code) and NFPA 30A (Automotive and Marine Service Station Code). Failure to seal conduits in accordance with NFPA 30A, and NFPA 70 could allow flammable vapors to travel through the conduit in the ATG console. An explosion could result causing serious injury, property loss, or death.

You must install a weatherproof, electrical junction box inside each manhole. The junction box should be installed high on the manhole wall to prevent it from being submerged during heavy rains.

Caution 

Seal all threaded fittings and conduit threads to produce a weatherproof seal during installation/maintenance.

Electrical Wiring

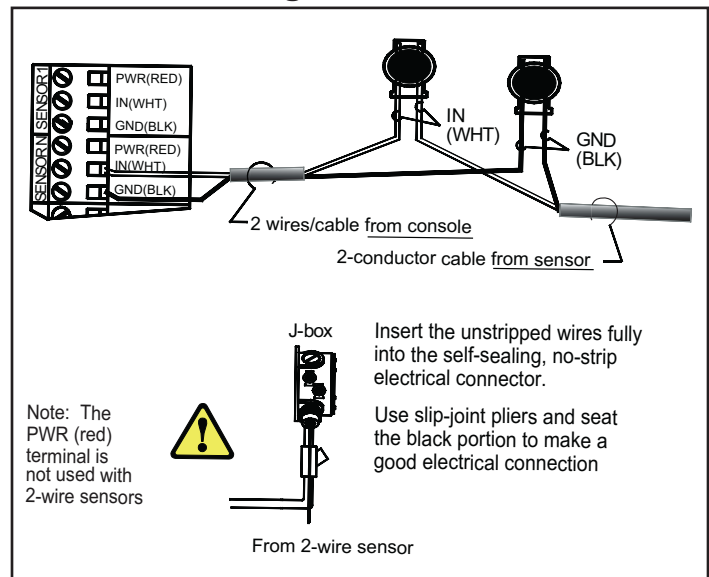

Figure 4: TSP-ULS Wiring

Reference the ATG Installation Manual and see Figure 4 (above) for TSP-ULS sensor wiring details. The two-wire TSP-ULS sensor does not have a red (power) conductor, therefore, the PWR (RED) interface terminal at the console is not used. When a 3-conductor Alpha cable is used, the red conductor can be clipped or taped back on both ends.

Testing the TSP-ULS

Testing this device is a matter of rotating the sensor 180 degrees with the bottom up, to cause an alarm at the ATG console. Test the sensor for proper operation on a yearly basis, or more frequently per local code.

Record Sensor Location

Sensor	Channel # / Notes



Franklin Fueling Systems

www.franklinfueling.com

3760 Marsh Road • Madison, WI 53718, U.S.A.
Tel: +1 608 838 8786 • Fax: +1 608 838 6433
Tel: USA & Canada 1 800 225 9787 • Tel: México 001 800 738 7610

Franklin Fueling Systems GmbH
Rudolf-Diesel-Strasse 20 • 54516 Wittlich, GERMANY
Tel: +49-6571-105-380 • Fax: +49-6571-105-510

