

INCON®



Franklin Fueling Systems

ATG Moormann Interface

Installation Guide

Contents

Notice	ii
Important Safety Messages	iii
Introduction	1
New Moormann ATG Interface Installation	1
Moormann ATG Interface Retrofits	5
Figure A.....	7

Notice

FFS reserves the right to change this document and specifications at any time without notice. FFS makes no expressed or implied warranty with regard to the contents of this manual. FFS assumes no liability for errors or omissions, or for any damages, direct or consequential, that may result from the use of this document or the equipment that it describes.

Inspection of Materials

Visually inspect all components for defects or damage prior to installation. If any defect or damage is found, do not use the product and contact FFS for further assistance.

Contacting Franklin Fueling Systems (FFS)

Please feel free to contact us by mail at:

Franklin Fueling Systems
3760 Marsh Rd.
Madison, WI 53718 USA

Or contact us by phone, fax or e-mail:

Tel: +1 800 225 9787 **E-mail:** sales@franklinfueling.com
Fax: +1 608 838 6433 techserve@franklinfueling.com
International Tel: México 001 800 738 7610

Office & Sales Hours: 8am to 5pm CST - Monday through Friday
Technical Support Hours: 7am to 7pm CST - Monday through Friday

Please visit our web site at www.franklinfueling.com

Important Safety Messages

FFS equipment is designed to be installed in association with volatile hydrocarbon liquids such as gasoline and diesel fuel. Installing or working on this equipment means working in an environment in which these highly flammable liquids may be present. Working in such a hazardous environment presents a risk of severe injury or death if these instructions and standard industry practices are not followed. Read and follow all instructions thoroughly before installing or working on this, or any other related, equipment.

For safety reasons, we have taken particular care in the design of this product to limit power in the wiring to the storage tanks and to keep that wiring physically separated from other wiring. It is your responsibility to maintain the effectiveness of these safety features by installing this product in accordance with the instructions and warnings which follow. Failure to do so could create danger to life and property, and result in voiding all warranties connected with these product

As you read this guide, please be aware of the following symbols and their meanings:

Warning  This symbol identifies a warning. A warning sign will appear in the text of this document when a potentially hazardous situation may arise if the instructions that follow are not adhered to closely. A potentially hazardous situation may involve the possibility of severe bodily harm or even death.

Caution  This is a caution symbol. A caution sign will appear in the text of this document when a potentially hazardous environmental situation may arise if the instructions that follow are not adhered to closely. A potentially hazardous environmental situation may involve the leakage of fuel from equipment that could severely harm the environment.

Warning  Follow all applicable codes governing the installation and servicing of this product and the entire system. Always lock out and tag electrical circuit breakers while installing or servicing this equipment and any related equipment. A potentially lethal electrical shock hazard and the possibility of an explosion or fire from a spark can result if the electrical circuit breakers are accidentally turned on during installation or servicing. Use only non-sparking tools. Please refer to the *Installation Guide* for this equipment, and the appropriate documentation for any other related equipment, for complete installation and safety information.







Warning  Follow all federal, state and local laws governing the installation of this product and its associated systems. When no other regulations apply, follow NFPA codes 30, 30A and 70 from the National Fire Protection Association. Failure to follow these codes could result in severe injury, death, serious property damage and/or environmental contamination.

Warning  Before entering a containment sump, check for the presence of hydrocarbon vapors. If these vapors are inhaled they could cause dizziness or unconsciousness, and, if ignited, hydrocarbon vapors could explode causing serious injury or death. Electronic and electrical petroleum monitoring equipment is often housed in containment sumps designed to trap hazardous liquid spills and prevent contamination of the environment, and, as a consequence, containment sumps can trap dangerous amounts of hydrocarbon vapors. If these vapor levels reach unsafe amounts, ventilate the sump with fresh air. While working in the sump, periodically check the atmosphere in the sump, if vapors reach unsafe levels, exit the sump and ventilate it before continuing work. Always have a second person standing by for assistance when working in, or around, a containment sump

Warning  Always secure the work area from moving vehicles. The equipment in this manual is usually mounted underground, so reduced visibility puts service personnel working on this equipment in danger from moving vehicles entering the work area. To help eliminate these unsafe conditions, secure the area by using a service truck to block access to the work environment, or by using any other reasonable means available to ensure the safety of service personnel.

Warning  This leak detector is designed for use in specific applications and in compliance with industry standards and practices. Using it in applications for which it was not designed or failure to follow industry standards and practices may cause the product to malfunction or fail. The following product information and operation instructions are particularly important.

- continued on the next page -

- Warning**  The hot, neutral and ground wires for FFS controllers must be dedicated wires to the service panel and to a dedicated circuit breaker — they should not be shared with any other system.
- Warning**  Conduits and wiring troughs from probes to the controller must not contain any other wires. Only probe, liquid sensor and line leak transducer wiring is allowed in the probe conduit.
- Warning**  Do not install the controller in a volatile, combustible, or explosive atmosphere. FFS systems must be installed in an environment that is within the operating specifications of the system. The controller must be located in a protective environment with a minimum temperature of 32° F (0° C) to a maximum temperature of 125° F (47° C). Check the system's specifications for further information or call Technical Services for assistance.
- Warning**  The conduit run from the probe to the controller must not exceed 2500 feet. All conduits must enter the controller through the pre-punched conduit openings. See the *Auto/Stik Installation Guide* for the correct wire requirements.
- Warning**  Meter the ATG Safety Ground to ground to verify that less than 1 ohm of resistance is present to ensure proper grounding.
- Warning**  Substitution of components may impair intrinsic safety or the effectiveness of the system operation, so please consult Technical Services whenever system modifications are required. Circuitry within the probe and the console barrier form an intrinsically safe, energy limited system. This system makes the FFS probe intrinsically safe for use in a Class I, Division C or D; Class II, Division E, F or G; or Class III Hazardous Location as defined by the National Fire Protection Association (NFPA).

Introduction

FFS's Moormann ATG interface gives an electronic means to read a Moormann mechanical gauge. The Moormann 7S tape gauge uses a 7 to 1 ratio that represents 7 feet of float movement in the tank for every foot of movement by the magnet in the tape gauge housing and can accommodate tanks up to 35 feet tall. The Moormann 9S tape gauge uses a 9 to 1 ratio that represents 9 feet of float movement in the tank for every foot of movement by the magnet in the tape gauge housing and can accommodate tanks up to 50 feet tall. The 7:1 or 9:1 ratio will be selected as part of programming the probe data in the FFS ATG. Please see the ATG Programming Manual for further details.

New Moormann ATG Interface Installation

The following step-by-step instructions describe the process for installing a Moormann gauge. Refer to Figure A for an assembly diagram.

1. Identify a desirable gauge position on the ground, and locate or install a suitable inlet fitting on the tank top near this position (minimum 1" NPT, 2" NPT preferred). This fitting should be adjacent to or in the vicinity of a manhole large enough to pass the gauge float through (see Figure A, Item 2). Mark the top edge of the tank directly above the ground location for the gauge. Open the tank manhole access.

Warning  **Observe all necessary precautions before opening the manhole or attempting to attach a new inlet fitting.**

2. Install a short, 2" NPT galvanized nipple, with adapters if necessary, in the tank opening. The nipple should be of sufficient length for the horizontal gauge pipe to clear any tank protrusions or obstructions.

Note: Use galvanized pipe and fittings for all customer-supplied plumbing and a suitable pipe thread sealant on all threaded joints.

3. Thread one gauge elbow (Figure A, Item 4) onto the tank nipple. Tighten the elbow down until the open end points towards the mark on the tank's edge from Step 1.
4. Obtain the lateral dimension from the end of the installed elbow to the edge of the tank from the mark in Step 1. Allow for the following:
 - Gauge vertical clearance from the side of the tank — minimum 12"
 - Thread engagements
 - Offset for second elbow installationDetermine the horizontal length of the two inch section of pipe. Cut and thread this section of pipe.

5. Install the second gauge elbow (Figure A, Item 4) on one of the 2" pipes from Step 4.
6. Install the supplied 2" x 1" reducing bushing (Figure A, Item 5) into the other end of this elbow. Thread a short, 1" pipe nipple with half of a union into this bushing. Tighten all of the threaded joints.
7. Thread the other end of the 2" pipe assembly from Step 6 into the gauge elbow on top of the tank and tighten it until the outside elbow points down.
8. Level the horizontal 2" pipe assembly with temporary wood bracing.
9. Set the gauge housing (Figure A, Item 9) with the eccentric cap (Figure A, Item 6) on the ground directly below the overhanging elbow. Measure from the union half on the upper elbow to the 1" pipe fitting on the eccentric cap. Allowing for thread engagement, cut and thread a suitable length of 1" galvanized pipe.
10. Connect the remaining half of the 1" union from Step 6 to one end of the pipe from Step 9. Remove and thread the eccentric cap (Figure A, Item 6) to the other end of this pipe. Align and assemble the eccentric cap to the union half attached to the upper gauge elbow and tighten the union so that the eccentric cap's 3/4" NPT probe port (see Figure A) is closest to the wall of the tank.

11. Install the large pulley end of one of the pulley racks (Figure A, Item 7) to the eccentric cap using a cotter pin (Figure A, Item 17). The 7 series gauge racks have three rollers and the 9 series has four rollers.
12. Using two additional cotter pins, connect both counterweights (Figure A, Item 10) to the second pulley rack. The counterweights attach to the two holes on the bracket sides adjacent to the smallest pulley.
13. Place the counterweight assembly on the ground directly beneath the eccentric cap pulley rack. Position the assembly so that the small pulley in the pulley rack (the cotter pin end) is on top.
14. Remove the covers from the two gauge roller elbows.

Caution  **While working with the gauge tape, use care not to kink or bend it. Carefully unroll the tape and stretch it out prior to threading. It is helpful if there is someone threading it from the top of the tank while, simultaneously, someone on the ground turns the roller brackets. Wear gloves when working with this kind of tape because its edges are sharp.**

15. With the numbered side up, starting from the tank-mounted elbow, thread the cotter pin bracket end of the gauge tape (Figure A, Item 8) through the piping all of the way to the eccentric cap. Make certain that the tape passes outside of the elbow rollers. Attach a pair of vice grip pliers to the other end of the gauge tape on the top of the tank so that the tape is secure and does not move during installation.
16. At the eccentric cap, thread the cotter pin bracket end of the tape through and around the lower roller (the largest roller) in the counterweight assembly (Figure A, Item 10). Thread from front to back or towards the storage tank — the numbered side of the tape should be facing you as you do this.
17. Continue with this end of the tape and thread it around the top roller (the largest roller) on the roller bracket attached to the eccentric cap, threading it from front to back. Continue on to the lower bracket and back to the upper bracket, threading the tape around the outside of each consecutive roller once. *Use care and do not twist the tape.* The numbered side will always be to the outside in both the front and the back.
18. If the roller brackets are threaded properly, you will finish up on the bottom of the roller bracket attached to the eccentric cap. Continue from this roller to the counterweight assembly and align the cotter pin bracket end of the tape to the top ears on the roller bracket in the counterweight assembly.
19. Locate the magnet bracket (Figure A, Item 19). Using the “magnet detail” on Figure A as a reference, align the magnet bracket’s arms from the “back side” of the counterweight assembly to the outside of the lower roller bracket’s mounting ears. The magnet bracket tube will be outside of the tape layers and the long cylinder portion of the magnet assembly should point up towards the top of the probe. Assemble the magnet bracket and gauge tape end to the roller bracket ears with a cotter pin (Figure A, Item 17).

Caution  **Remove all of the twists in the tape to avoid kinking it before proceeding to the next step.**

20. From the tank-mounted elbow assembly on the tank top, pull the gauge tape out until all of the tape slack is removed. Continue pulling tape, lifting the counterweight off of the ground, until the two roller brackets meet. Using a piece of electrical tape and vice grips, hold the tape temporarily at the elbow assembly. Install the flange gasket (Figure A, Item 14) on the gauge housing (Figure A, Item 9). Carefully insert the counterweight assembly into the gauge housing and place the gauge housing upright and under the eccentric cap. The gauge housing observation window must be positioned in front directly below the vertical 1" pipe. Line up the bolt holes and the gasket, then bolt the eccentric cap to the gauge tube.
21. Thread the male reducing adapter into the eccentric cap’s $\frac{3}{4}$ " opening (marked as the “probe hole” in Figure A).
22. Slide the probe (Figure A, Item 20) through the male reducing adapter and through the magnet bracket tube. Carefully allow the probe to slide all of the way down until it rests on the gauge housing bottom. Verify that the probe passed through the magnet bracket tube by viewing this assembly through the gauge housing observation window.

23. Remove the vice grips and electrical tape, and slowly allow the counterweight assembly to drop down in the gauge tube. Once the weight assembly is on the bottom of the tube and the tape is slack, thread the loose end of the tape through the short nipple on the tank top and fish this end out of the manhole access.
24. Fasten the tape clamp (Figure A, Item 3) to the float (Figure A, Item 2) using a cotter pin with a flat washer at the head of the probe. Measure down to the product level and obtain an estimate of the dimension from the roller elbow to the product level. Thread the free end of the gauge tape through the float tape clamp as shown in Figure A. Slide the clamp up the tape to a point where the distance to the roller is at least 6" shorter than the dimension obtained to the liquid level. Do not cut the tape excess at this time. Tighten the clamp only enough to prevent the tape from sliding because a final adjustment will be necessary later — over-tightening at this time will damage the tape.
25. Lower the float assembly into the tank (**do not drop it**) and carefully continue feeding the tape in until the float rests on the product or on the tank bottom. FFS suggests that a small hand line be temporarily attached to the float bracket to assist in this initial float installation. If there is slack remaining in the gauge tape, the float tape clamp will need to be readjusted up the free end of the tape an additional amount to remove slack in the tape.
26. At the gauge tube window (Figure A, Item 1) reach in with a small screwdriver and place the outside tape strand over the tape guide at the window. Be careful not to bend the tape or hook more than one tape strand. Install the observation window pointer to the tape guide and adjust it to the middle of the range.
27. Measure the level of the liquid in the tank for an initial level gauge alignment. If the tank is empty, the initial level will be 1 $\frac{3}{8}$ " (minimum float drift).
28. Read the actual gauge level at the site window of the gauge tube.
29. Visually inspect and determine the difference between the gauge readout and the actual tank level.
30. Remove the gauge float from the tank by extracting it through the manway with tape or a previously attached hand line.
31. Mark the gauge tape where the float tape clamp is currently located. If the gauge reading was higher than the actual tank level, slide the float tape clamp up the gauge tape from this initial mark the exact amount of the difference between the two readings.

Example:

Tank Gauge Reading:	15' and 9 $\frac{3}{4}$ "	
Actual Tank Level Reading:	– 14' and 3 $\frac{1}{2}$ "	
Difference:	1' and 6 $\frac{1}{4}$ "	
Move float tape clamp up the tape:	1' and 6 $\frac{1}{4}$ "	

If the gauge reading was lower than the actual tank level, slide the float tape clamp down the tape a distance equal to the difference between the two readings.

32. If you are uncertain that your adjustments are correct or if the initial adjustment was large, then repeat Steps 23, 24, 26, 27, 28 and 29 before proceeding.
33. Tighten the tape clamp to a point where the tape is deformed by the clamp's dimples. Remove the small hand line attached for float removal, and cut off any excess tape below the float tape clamp. Carefully reinstall the float into the tank and lower it to the product level. Inspect the tape for twists or kinks and carefully remove any if they are found.
34. Install probe cable (Figure A, Item 21) to the connector on the top of the probe. Insert this wire through the hole at the top of the weather head (Figure A, Item 22) and slide the weather head onto the head of the probe (see installation guide 000-0113).

35. Install the UV guard (Figure A, Item 23) over the probe cable and route the probe cable to the junction box. The spiral UV guard should completely cover the exposed yellow probe cable and protect it from sun exposure.
36. Complete connections to the tank gauge. See the original Tank Gauge installation instructions to facilitate connection and setup for your system. If you are working with an INCON system or an EBW ASII or ASJR system, you will have received a TSP-LL2 style probe and should use instructions 000-1050 for INCON systems and 000-2050 for ASII and ASJR systems. If you are working with an EBW AutoStik 960 or 970 system, you will have received a 960 style probe and should use instructions F-6146.
37. The Moormann gauge reading should now equal the actual tank level. The pointer finger may be adjusted to fine tune the level reading.
38. Plumb and level the complete assembly. Fix a base for the gauge housing using one of the following: a wood post, a steel plate welded to the tank, or concrete.

Caution  **Do not weld gauge housing to the tank.**

39. Assemble the observation window frame assembly (Figure A, Item 1), the window glass (Figure A, Item 15), and the gaskets (Figure A, Item 12) to the gauge housing window opening. Alternatively, tighten the bolts to avoid breaking the window glass.
40. Assemble the covers to the roller elbows (Figure A, Item 4) using the gaskets (Figure A, Item 13) provided. Replace the existing tank manway and seal with a new tank manway and seal.
41. Install a ¼" drain plug in the bottom of the gauge housing. Tighten the probe male adapter fitting. Install a ¾" pipe plug into the eccentric cap port noted as the "oil fill hole" in Figure A.

Note: In most climates, condensation will form on the inside of the tank and on the inside of the gauge housing. A drain plug at the bottom of the housing has been provided for draining the moisture that accumulates in the gauge. The gauge housing should be drained at least twice a year, usually in the spring and fall — in extreme cases however, the housing may need to be drained more frequently.

Note: Should condensation prove to be a severe problem, the gauge housing can be flooded to protect moving components with a clear, lightweight oil that is compatible with the product in the tank. To flood the gauge housing with such an oil, use the extra ¾" "oil fill hole" on the eccentric cap (refer to Figure A).

Moormann ATG Interface Retrofits

The steps below explain how to install the FFS Bulk/Stik aboveground tank gauge equipment to an existing Moormann gauge. Refer to Figure A and in the back of this manual for an assembly diagram.

Programming Tip: Record the tank level reading from the Moormann gauge before proceeding. To maintain an accurate gauge reading, the tank should be idle during this retrofit process.

1. Remove the ¼" (6.35 mm) drain plug in the bottom of the gauge tube and separate the 1" union and the 1" vertical pipe riser from the gauge tube to the tank top (refer to Figure A).
2. Remove the covers from the roller assemblies (Figure A, Item 4).
3. Wedge a suitable length of lumber under the 2" horizontal pipe between the roller assemblies until the 1" union from Step 1 separates at least 2".

Note: While working with the gauge tape, use care not to kink or bend it.

Warning  **Wear gloves when working with gauge tape because its edges may be sharp.**

4. From the tank-mounted roller assembly, slowly pull the gauge tape out, raising the counterweights in the gauge tube, until the gauge reads a fuel level of approximately two feet. Using vice grip pliers and a piece of electrical tape to protect the tape, clamp the gauge tape at this roller assembly to prevent it from retracting beyond the rollers.
5. Remove all of the bolts from the gauge eccentric cap (Figure A, Item 6). Remove the gauge window assembly (Figure A, Item 1) and the tape pointer from inside of the window.
6. Carefully slip the gauge tape off of the window guide (located inside of the opening).
7. Carefully lift the eccentric cap off of the gauge tube and remove the counterweight assembly from the gauge tube (Figure A, Item 9). To do this, you may have to swing the upper section of the 1" pipe away from the lower union half, but, while performing this step, be careful not to kink the gauge tape at the 1" union halves. In lieu of having someone hold the eccentric cap and counterweight assemblies while the following steps are performed, you can reattach the 1" union and allow this assembly to hang outside of the gauge tube from the 1" pipe.
8. Remove the cotter pin (Figure A, Item 17) attaching the gauge tape to the counterweight assembly, and slowly withdraw it from the roller assemblies.
9. Remove the upper roller bracket (Figure A, Item 7) from the eccentric cap. Remove the eccentric cap from the 1" pipe and discard the cap.
10. Install the new eccentric cap provided with the FFS Bulk/Stik Retrofit Kit. The new cap has three threaded holes; use a suitable pipe sealant on the threads.
11. Install the large pulley end of the pulley rack (Figure A, Item 7) to the eccentric cap (Figure A, Item 6) using a cotter pin (Figure A, Item 17). The 7S series gauge racks have three rollers and the 9S series gauge racks have four rollers.
12. While supporting the counterweight assembly directly beneath the eccentric cap pulley rack, position the assembly so that the small pulley in the pulley rack (the cotter pin end) is on top.
13. Thread the cotter pin bracket end of the tape through and around the lower roller (largest roller) in the counterweight assembly (Figure A, Item 10). Thread from front to back or towards the storage tank. The numbered side of the tape should be facing you as you do this.
14. Continue with this end of the tape and thread it around the top roller (largest roller) on the roller bracket attached to the eccentric cap, threading from back to front. Continue on to the lower bracket and back to the upper bracket, threading the tape around the outside of each consecutive roller once — use care not to twist the tape. The numbered side will always be to the outside in both the front and the back.

15. If the roller brackets are threaded properly, you will finish with the last roller on the bottom of the roller bracket attached to the eccentric cap. Continue from this roller to the counterweight assembly and align the cotter pin bracket end of the tape to the top ears on the roller bracket in the counterweight assembly.
16. Locate the magnet bracket (Figure A, Item 19). Using the "magnet detail" in Figure A as a reference, align the magnet bracket's arms from the "back side" of the counterweight assembly to the outside of the lower roller brackets mounting ears. The magnet bracket tube will be outside of the tape layers and the long cylinder portion of the magnet assembly points up. Assemble the magnet bracket and gauge tape end to the roller bracket ears with a cotter pin (Figure A, Item 17).

Caution  **Remove all of the tape twists before proceeding to avoid kinking the tape.**

17. Install the new flange provided (Figure A, Item 14) on the gauge housing (Figure A, Item 9). Disconnect the 1" union if this was used to support the eccentric cap and roller assemblies. Carefully reinsert the counterweight assembly into the gauge housing. Align the 1" pipe directly over the gauge tube window. Align the bolt holes and the gasket, then bolt the eccentric cap to the gauge tube.
18. Thread the male reducing adapter into the eccentric caps $\frac{3}{4}$ " opening marked for the probe in Figure A.
19. Slide the probe (Figure A, Item 20) through the male reducing adapter and through the magnet bracket tube. Carefully allow the probe to slide all of the way down until it rests $\frac{1}{4}$ " from the bottom of the gauge housing. Verify that the probe passed through the magnet bracket tube by observing this assembly through the gauge housing observation window.
20. Remove the vice grip pliers and electrical tape and slowly allow the counterweight assembly to drop down in the gauge tube.
21. Reinstall the elbow assembly covers using the new gaskets provided (Figure A, Item 13).
22. At the gauge tube window (Figure A, Item 1), reach in with a small screwdriver and place the outside tape strand over the tape guide at the window. Be careful not to bend the tape or hook more than one tape strand. Install the observation window pointer to the tape guide and adjust it for an initial tank level reading.
23. Assemble the observation window frame assembly (Figure A, Item 1), the window glass (Figure A, Item 15), and the new gaskets (Figure A, Item 12) to the gauge housing window opening. Alternately, tighten the bolts to avoid breaking the glass.
24. Tighten the probe male adapter fitting. Install a $\frac{3}{4}$ " pipe plug into the eccentric cap port noted as the "oil fill hole" in Figure A.
25. Replace the old $\frac{1}{4}$ " drain plug in the bottom of the gauge tube with a new $\frac{1}{4}$ " drain plug.
26. Install probe cable (Figure A, Item 21) to the connector on the top of the probe. Insert this wire through the hole at the top of the weather head (Figure A, Item 22) and slide the weather head onto the head of the probe (see installation guide 000-0113).
27. Install the UV guard (Figure A, Item 23) over the probe cable and route the probe cable to the junction box. The spiral UV guard should completely cover the exposed yellow probe cable and protect it from sun exposure.
28. Complete connections to the tank gauge. See the original Tank Gauge installation instructions to facilitate connection and setup for your system. If you are working with an INCON system or an EBW ASII or ASJR system, you will have received a TSP-LL2 style probe and should use instructions 000-1050 for INCON systems and 000-2050 for ASII and ASJR systems. If you are working with an EBW AutoStik 960 or 970 system, you will have received a 960 style probe and should use instructions F-6146.

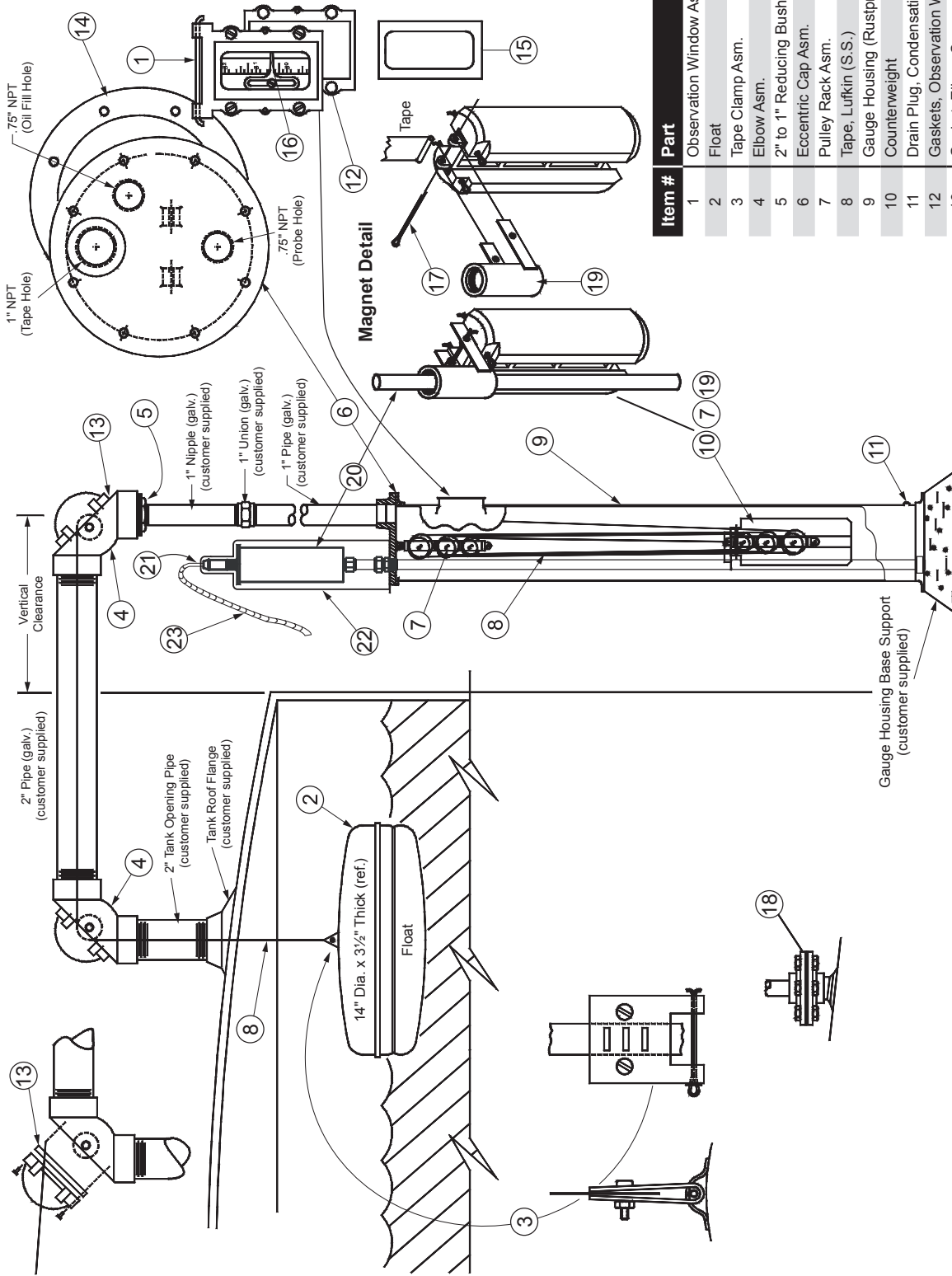

Item #	Part
1	Observation Window Asm.
2	Float
3	Tape Clamp Asm.
4	Elbow Asm.
5	2" to 1" Reducing Bushing
6	Eccentric Cap Asm.
7	Pulley Rack Asm.
8	Tape, Lufkin (S.S.)
9	Gauge Housing (Rustproofed Steel)
10	Counterweight
11	Drain Plug, Condensation
12	Gaskets, Observation Window
13	Gasket, Elbow Cap
14	Gasket, Eccentric Cap
15	Glass, Window
16	Indicator Finger (S.S.)
17	Wire Pin (S.S.)
18	Alignment Flange (Optional)
19	Magnet Bracket
20	Probe
21	Probe Cable
22	Weather Head
23	UV Guard

Figure A

