



**Franklin Fueling Systems**

# **DC400 Dispensing Cutoff System**

*DC404 and DC406*

## **Installation Instructions**

**Franklin Fueling Systems** • 3760 Marsh Rd. • Madison, WI 53718 USA

Tel: +1 608 838 8786 • 800 225 9787 • Fax: +1 608 838 6433 • [www.franklinfueling.com](http://www.franklinfueling.com)

# Important Safety Messages

Franklin Fueling Systems (FFS)/Healy equipment is designed to be installed in association with volatile hydrocarbon liquids such as gasoline and diesel fuel. Installing or working on this equipment means working in an environment in which these highly flammable liquids may be present. Working in such a hazardous environment presents a risk of severe injury or death if these instructions and standard industry practices are not followed. Read and follow all instructions thoroughly before installing or working on this, or any other related, equipment.

As you read this guide, please be aware of the following symbols and their meanings:

**Warning**  This symbol identifies a warning. A warning sign will appear in the text of this document when a potentially hazardous situation may arise if the instructions that follow are not adhered to closely. A potentially hazardous situation may involve the possibility of severe bodily harm or even death.

**Caution**  This is a caution symbol. A caution sign will appear in the text of this document when a potentially hazardous environmental situation may arise if the instructions that follow are not adhered to closely. A potentially hazardous environmental situation may involve the leakage of fuel from equipment that could severely harm the environment.

---

**Warning**  **Follow all applicable codes governing the installation and servicing of this product and the entire system. Always lock out and tag electrical circuit breakers while installing or servicing this equipment and any related equipment. A potentially lethal electrical shock hazard and the possibility of an explosion or fire from a spark can result if the electrical circuit breakers are accidentally turned on during installation or servicing. Please refer to the Installation and Owner's Manual for this equipment, and the appropriate documentation for any other related equipment, for complete installation and safety information.**

**Warning**  **Follow all federal, state and local laws governing the installation of this product and its associated systems. When no other regulations apply, follow NFPA codes 30A and 70 from the National Fire Protection Association. Failure to follow these codes could result in severe injury, death, serious property damage and/or environmental contamination.**

**Warning**  **Always secure the work area from moving vehicles. The equipment in this manual is usually mounted underground, so reduced visibility puts service personnel working on this equipment in danger from moving vehicles entering the work area. To help eliminate these unsafe conditions, secure the area by using a service truck to block access to the work environment, or by using any other reasonable means available to ensure the safety of service personnel.**

**Warning**  **Use circuit breakers for multiple disconnect to turn off power and prevent feedback from other dispensers.**

## Product Description

The DC400 system uses a sump sensor (latching float sensor or non-latching optical sensor) to detect the presence of liquid in the STP (Submersible Turbine Pump) or dispenser sump. If liquid is detected, the system will shut down power to the STP or dispenser.

## Installation in a Dispenser

Unpack unit and check for shipping damage. The system consists of two components, the controller and the sensor.

1. Shut off the power to the dispenser:

**Warning**  **Remove power to avoid possible electrocution or ignition of explosive gasoline vapors.**

2. Remove the cover from the junction box and locate a spare threaded hub.
3. Remove the plug from the hub and if needed install a reducing bushing so that you have a 1/2" threaded opening.
4. The controller has 7 wires extending from the end of a 1/2" nipple. Feed the 7 wires through this opening and thread the 1/2" nipple into a hub.
5. Tighten the nipple using a wrench on the nipple and not the body of the controller.
6. Connect the wires as shown in Figure 1.
7. Plug the sensor into the 4-wire female plug on the end of the controller. Wrap the plugs with the electrical tape.

**CAUTION:** **Never plug or unplug the sensor unless the controller is de-energized. Doing so will damage the unit.**

8. Place the sensor into the bottom of the sump at the level to cause dispenser shutdown (Figure 2). Remember that the unit will shut down when the sensor detects liquid.

9. Loop and secure the excess cable with a tie-wrap so that the sensor is suspended at the appropriate position. The S404 float sensor must be installed in a vertical orientation for proper operation!
10. Replace the junction box cover.
11. Turn the dispenser power back on. The dispenser should operate normally.
12. If the float sensor causes the dispenser to shut down, the sensor must be reset by pushing the float back down with the provided reset tool through the vent hole in the sensor top to restore power to the dispenser. The optical sensor does not need to be reset.

**Note:** Use only the provided reset tool to push the float down.

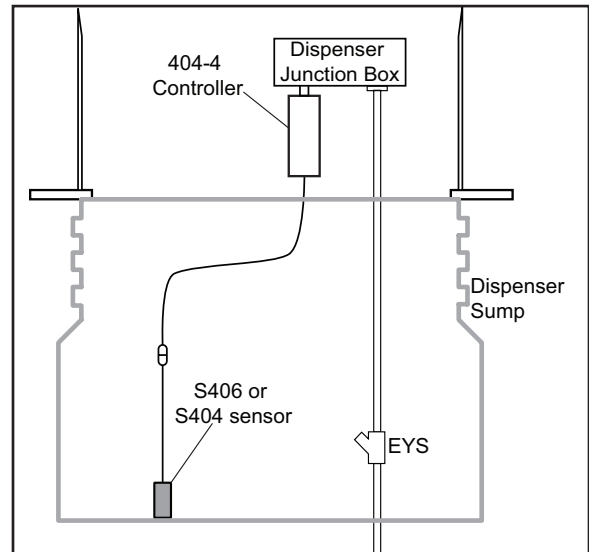

Figure 2: System Installed in Dispenser Sump

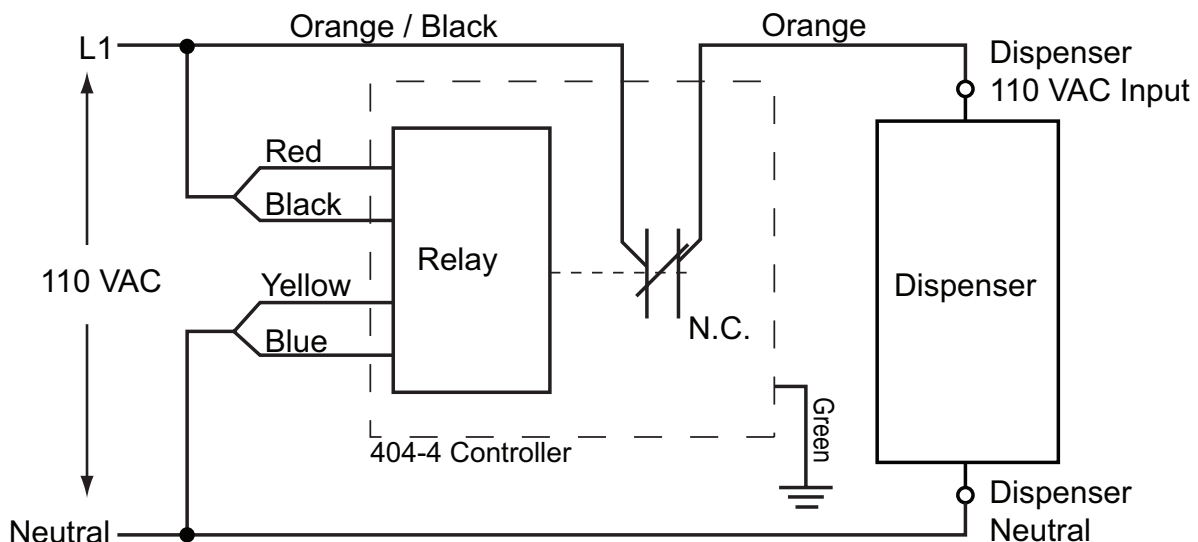



Figure 1: 110 VAC Wiring Schematic for Controller Dispenser Connection

# Installation in Submersible Pump Sump

**NOTICE** This controller is not for use with 3-phase pumps or Variable Frequency pump installations.

1. Shut off the power to the STP.

**Warning**  Remove power to avoid possible electrocution or ignition of explosive gasoline vapors.

2. Remove the plug from the STP electrical junction box cover and save the plug.

If the STP junction box does not have a removable plug or opening, installation adapters are available as listed below.

Installed STP	Installation Adapter
FE Petro	TS-FE
Red Jacket	TS-RJ
Red Jacket Quantum	TS-RJQ

Determine what fittings you will need to position the controller. A typical means of connecting the controller to an STP is shown on Figure #3. Assemble the fittings onto the controller and tighten.

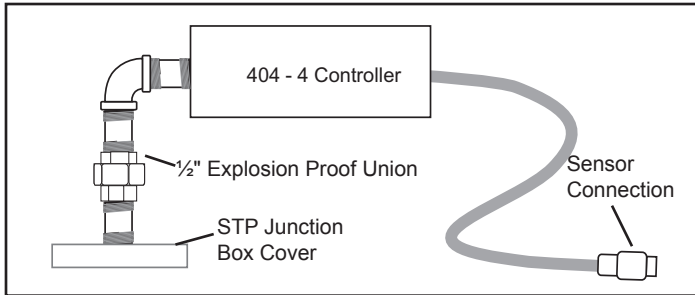

Figure 3: Connection to STP

3. Connect the 7 wires as shown on Figure #4.

4. Disconnect the union (Figure 3) and carefully position the connected wires into the electrical box. Thread the reducing bushing into the threaded opening, being careful not to scrape or twist the wires. Reconnect and tighten the union.
5. Plug the sensor into the 4-wire female plug on the end of the controller. Wrap the plugs with the electrical tape.

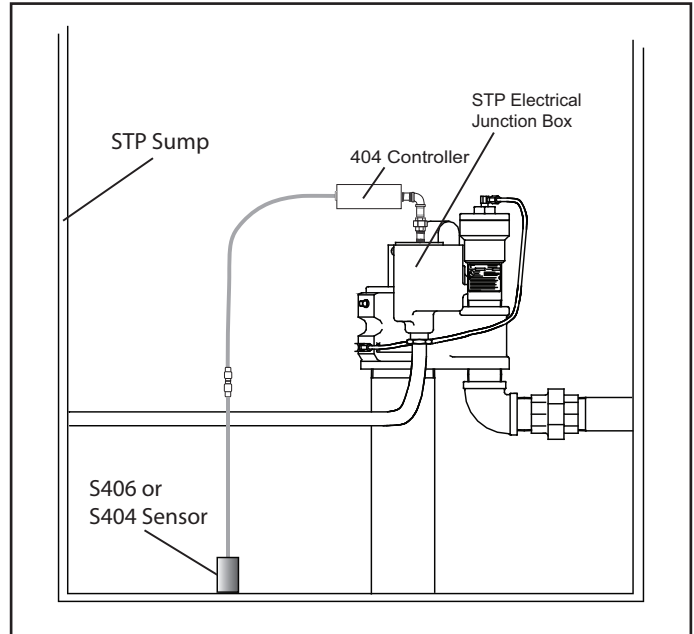

Figure 5: STP Sump Installation

6. Place the sensor into the bottom of the sump at the level to cause pump shutdown. Remember that the unit will shut down when the sensor detects liquid.

**CAUTION:** Be sure to plug the sensor into the controller before turning the power back on to prevent damage to the controller.

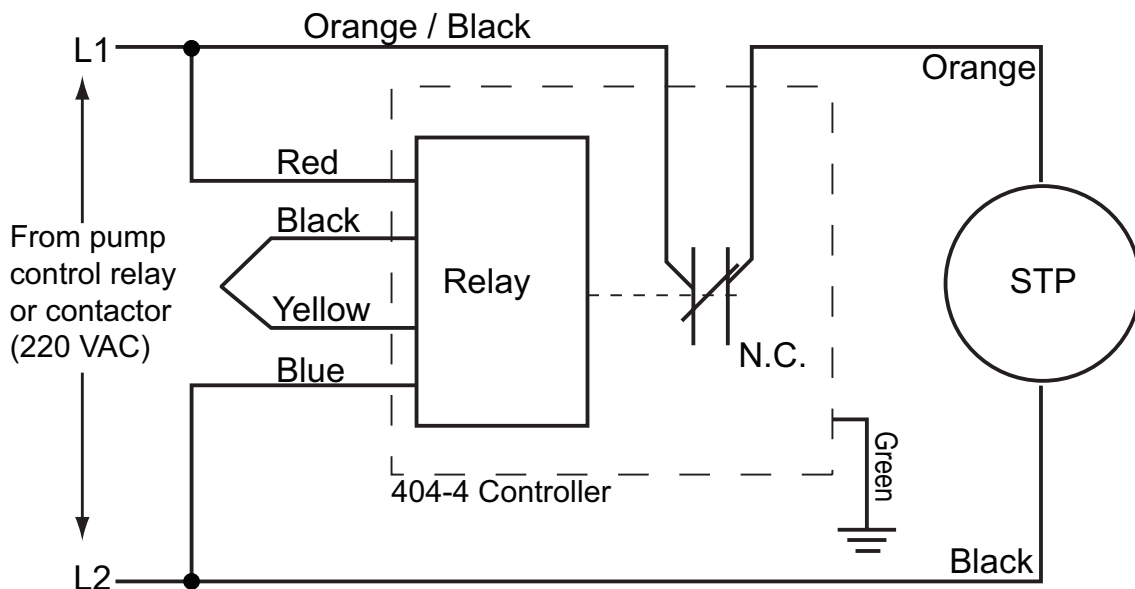

Figure 4: 220 VAC Wiring Schematic for STP Connection

7. Turn the circuit breaker back on and test for proper operation by authorizing a dispenser of that product and feeling the top of the pump for vibration.
8. Test the sensor as described in the Testing section.

## Alarm Wiring

The relay contacts (Orange/Black and Orange) are normally closed dry contacts that will open when liquid is detected. This enables the 404-4 controller to be wired into other configurations.

**Note:** You must not exceed the relay contact rating of 250 VAC, 12 A.

Figure 6 shows an example of alarm wiring for applications that do not require a positive shutdown.

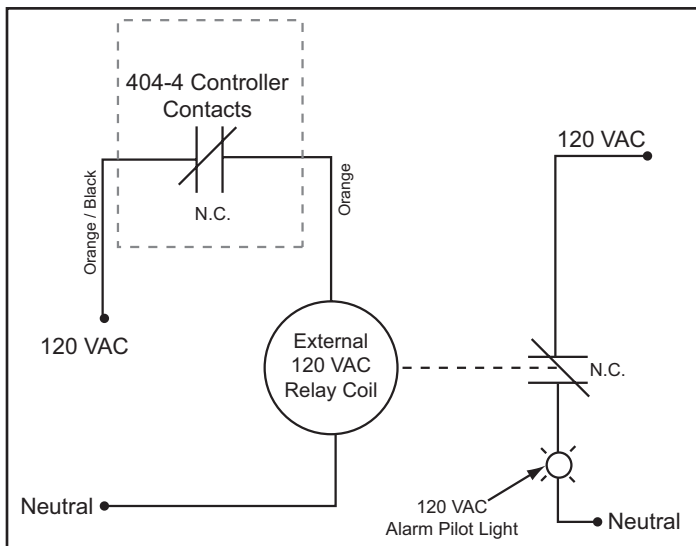

**Figure 6: Wiring Example for Non-Positive Shutdown**

In the example above, the alarm light illuminates when the 404-4 controller senses liquid. Other possibilities exist for connecting to an external monitoring device, such as an INCON T5 Tank Gauge.

## Testing

Test the function of the system according to applicable codes, and at least annually to verify proper system operation.

### To Test The Float Sensor Cutoff

1. Insert the sensor in a vessel of water. The dispenser should shut down (remove power from the orange wire) when the sensor float rises in water about ½" and makes contact with the top of sensor.
2. Remove the sensor from the water and reset the sensor by pushing the float back down with the provided reset tool to restore power to the pump or dispenser.

### To Test the Optical Sensor

**Note:** This sensor is affected by ambient light and should be shielded from direct light.

**Warning**  **Always disconnect power before checking the optical sensor. Opening up the sensor sump location to light may cause the sensor to change state.**

1. Insert the sensor in a vessel of water. The pump or dispenser should shut down (by removing power from the orange wire) when the water level rises in water a little less than 1".
2. The sensor should reset after it is removed from the water.

## Troubleshooting

If the controller relay repeatedly cycles or oscillates when the sensor is tripped, it is likely that the controller is switching its own power. Check the wiring diagram and confirm that the controller is wired properly. Make sure that the orange/black, red and black wires are tied to power from the breaker and the orange wire feeds the dispenser. If problems continue, please contact FFS Technical Support at 800-984-6266.



**Franklin Fueling Systems**

[www.franklinfueling.com](http://www.franklinfueling.com)

3760 Marsh Road • Madison, WI 53718, U.S.A.

Tel: +1 608 838 8786 • Fax: +1 608 838 6433

Tel: USA & Canada 1 800 225 9787 • Tel: México 001 800 738 7610

**Franklin Fueling Systems GmbH**

Rudolf-Diesel-Strasse 20 • 54516 Wittlich, GERMANY

Tel: +49-6571-105-380 • Fax: +49-6571-105-510