



Aboveground Storage Transition Sump (AST-2922)

Installation Instructions

Warning  Follow all federal, state and local laws governing the installation, testing and inspection of this product and its associated systems. When no other regulations apply, follow NFPA codes 30, 30A and 70 from the National Fire Protection Association. Failure to follow these codes could result in severe injury, death, serious property damage and/or environmental contamination.

Caution  The part described in this document is one element of a system. All components of this system should be installed according to the manufacturer's specifications so that the system's integrity is not compromised. Test the complete system after installation according to all pertinent local, state and federal laws to ensure its proper operation. Failure to properly verify operation could lead to environmental contamination or system degradation.

Procedure

1. Install an AST sump base in the excavated trench at a 30" burial depth (see Figure 1).
2. Remove the fiberglass lid, and install any entry boots in the sump. Note that bulkhead boots cannot be installed in a fiberglass lid.

Note: No entries should be installed in the bottom of a sump.

3. Assemble riser pipes with tees/elbows and APT fittings.
4. Install the pipes on the hose barbs.

Note: Pipe entries should be perpendicular (+/- 15 degrees) to flat surfaces only.

5. If required, you can install a SBK-3 (stabilizer bar kit) in the sump base.
6. Slide the lid over the riser pipes and place the lid on the steel frame.
7. Bolt the composite lid onto the steel frame using the bolts and sealing washers provided. Also, tighten the band clamps on any lid-mounted entry boots.
8. Backfill evenly around the sump with approved backfill. Do not over-compact the backfill, or you may distort the sump.

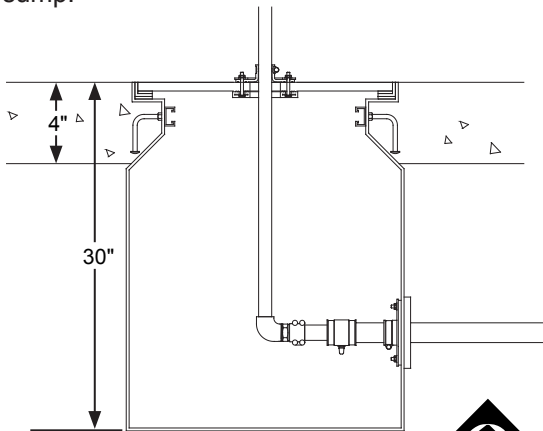
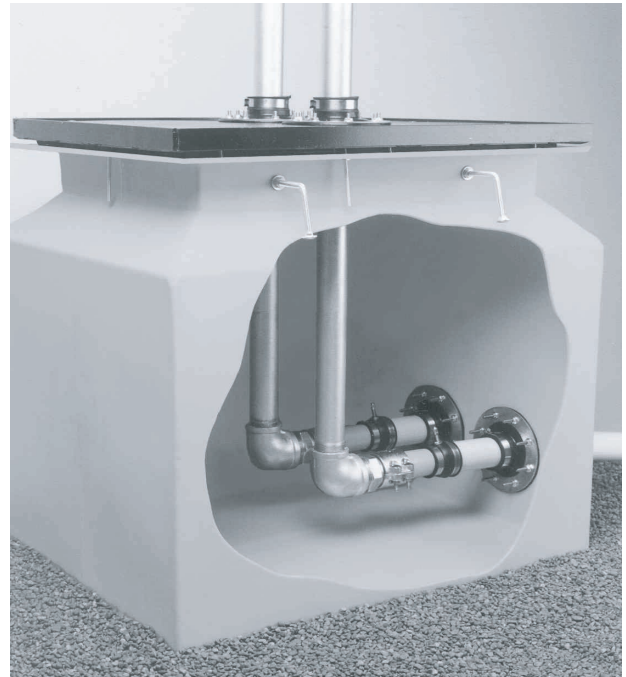

Figure 1



Note: See the *Installation Guide Overview* for proper backfill materials.

9. Pour concrete around the steel frame. Concrete must be poured to a minimum thickness of four inches (see Figure 1).

Note: This part is H2O load rated prior to the installation of entry boots. After penetrations have been made in the lid, the H2O load rating is invalidated.

Note: It is the contractor's responsibility to cover installed entry boots with a UV-resistant cover or lid in order to eliminate UV exposure.



Franklin Fueling Systems

3760 Marsh Road • Madison, WI 53718 U.S.A.

Tel: +1 608 838 8786 • Fax: +1 608 838 6433 • www.franklinfueling.com

Tel: USA & Canada 1 800 225 9787 • Tel: Mexico 001 800 738 7610