



Franklin Fueling Systems

# Large Mouth (LMx) Medium & Deep Dispenser Sump Installation Instructions

**Warning** Follow all federal, state and local laws governing the installation, testing and inspection of this product and its associated systems. When no other regulations apply, follow NFPA codes 30, 30A and 70 from the National Fire Protection Association. Failure to follow these codes could result in severe injury, death, serious property damage, environmental contamination and/or system degradation.

**Caution** The part described in this document is one element of a system. All components of this system should be installed according to the manufacturer's specifications so that the system's integrity is not compromised. Test the complete system after installation according to all pertinent local, state and federal laws to ensure its proper operation. Failure to properly verify operation could lead to environmental contamination.

**Note:** Do not install pipe entries into the bottom of dispenser sumps.

## Procedure

**Note:** Sumps must be installed at a depth where the finished level of the island form (or court, if no island is used) is flush with the top of the LMT (Large Mouth Top). Refer to Diagram 1 for the location of the concrete surface.

1. Determine the dispenser sump's proper burial depth and set it in an excavated trench as shown in Diagram 1.

**Note:** The proper burial depth will ensure an appropriate piping slope. See the *Installation Guide Overview* for a list of proper backfill materials and piping slope recommendations.

**Note:** The table below details the acceptable range of depths for correct entry boot installation. Consider these ranges when determining burial depths and sump cutdowns.

'B' Dimension	Sump Height
12-15"	Medium burial minus 9" (M-9)
15-18"	Medium burial minus 6" (M-6)
18-21"	Medium burial minus 3" (M-3)
21-28"	Medium burial (M)
27-30"	Deep burial minus 9" (D-9)
30-33"	Deep burial minus 6" (D-6)
33-36"	Deep burial minus 3" (D-3)
36-43"	Deep burial (D)

2. If necessary, trim the sump with a jigsaw and de-burr all of the rough edges. The dispenser sumps have trim areas in 3" increments, and must be cut on the smaller frame of the riser. Refer to Diagram 1 for trim locations.

3. Install any entry boots (see the appropriate instructions) or bulkhead boots (see the appropriate instructions).

**Note:** No entries should be made in the bottom of any sump.

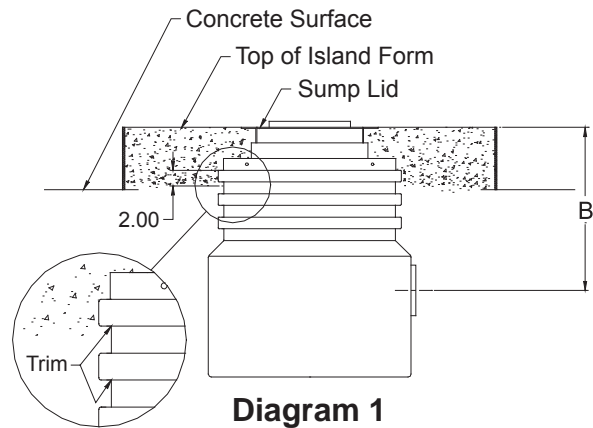

Diagram 1

4. Place the LMT on the sump and drill 9/32" holes through the sump wall, outside inward, using the holes in the lip of the LMT as a guide.

5. Assemble the riser pipes. Riser pipe assembly lengths should have properly mounted shear valves and maintain an appropriate piping slope.

6. Remove the LMT and set the riser assembly(s) into the dispenser sump.

7. Install pipes onto riser assemblies (see the appropriate instructions).

8. Place the LMT back on the sump and fasten it to the sump's base using the nuts and bolts that were provided. Start the bolts from the inside out and hand tighten them.

9. Install stabilizer bar kits into the LMT (see the appropriate instructions).

**Note:** The following steps take place after other system installation steps such as testing the primary pipe, the secondary pipe, etc.

10. Backfill evenly around the sump with approved backfill. Do not over-compact the backfill or you may distort the sump.
11. If an island form is to going be used, place the form around the dispenser sump and, using a reinforcing bar, support the island form at the proper elevation to correspond with the top of the LMT.
12. Determine the dispenser mounting locations and, if necessary, drill appropriately sized holes into the top flange to allow for different bolt patterns. Locate the supplied anchor bolts on the flange for mounting to the dispenser.
13. Pour concrete inside of the island form to create the court. Concrete must be poured a minimum of 2" below the bottom of the LMT (see Diagram 1).



**Franklin Fueling Systems**

3760 Marsh Road • Madison, WI 53718 U.S.A.

Tel: +1 608 838 8786 • Fax: +1 608 838 6433 • [www.franklinfueling.com](http://www.franklinfueling.com)

Tel: USA & Canada 1 800 225 9787 • Tel: Mexico 001 800 738 7610