



Franklin Fueling Systems

# Marina Piping

## Installation Guide Overview

*Secondarily contained MD & single wall MDD series piping*

### Overview

Franklin Fueling System's Metallic Ducted Marina Pipe (MD pipe) is a combination of APT's XP Series pipe and metallic conduit. MD pipe is specifically designed for use on aboveground installations and is commonly used in marinas, fuel oil lines and emergency generator feed and return lines. The metallic ducting provides a liquid-tight protective covering to enhance resistance to crushing, kinking, abrasion and other types of physical damage. It also provides added fire and UV protection and it can be used in both freshwater and saltwater marina applications. MD series pipe is shipped with single wall or secondarily contained pipe already installed into the metallic ducting, reducing installation time and the associated labor costs.

The metal jacket, the innermost layer of the ducting, consists of a smooth, double strip-wound galvanized steel layer, which is flexible yet impact resistant. The galvanized steel layer is then covered with a 1/8 inch thick thermoplastic coating that provides additional sealing to the steel layer assuring fluid tightness. This thermoplastic coating also contains a fire retardant and provides the UV resistant material needed for aboveground applications.

### Warranty, Testing, Record and Certification Information

Please refer to the *XP Installation Guide Overview* (771-232-00) for information on testing, records and certification. The *XP Series Warranty Certification and Site Maintenance Guide* (FFS-0029) contains both warranty information and 771-232-00.

### Marina Basics

Each marina or aboveground installation using MD pipe is unique, There are general procedures that are basic to all installations:

- To install MD series pipe, installers must be certified to install XP pipe and be knowledgeable of installation procedures required for FFS underground piping systems as noted in the *XP Installation Guide Overview* (771-232-00).

- FFS requires any connection area where lengths of pipe are terminated to be contained and monitored using leak detectors and monthly inspections. Piping connections, including those in MD series piping systems, must be made inside of approved containment areas to ensure environmental security. This means that containment sumps in underground and marina applications must be utilized and monitored.

### Operating Pressures

APT's XP product pipe has a maximum listed operating pressure of 100 psi.

### Flow Rates

Please contact FFS Technical Service for flow rate calculations.

### Bend Radius

All listed piping has a bend radius of **36"**.

### Part Numbers

Part Number	Description
XP-100-MDD	1" Single Wall Pipe
XP-150-MDD	1½" Single Wall Pipe
XP-175-MDD	1¾" Single Wall Pipe
XP-200-MDD	2" Single Wall Pipe
XP-100-MD	1" Secondary Contained Pipe
XP-150-MD	1½" Secondary Contained Pipe
XP-175-MD	1¾" Secondary Contained Pipe
XP-200-MD	2" Secondary Contained Pipe

### MD Buoyancy

Depending on the size of the MD series piping, it will have a buoyancy factor anywhere from neutral to 20% lighter than water before the product pipe is filled with fuel. After filling the primary pipe with fuel, the buoyancy factor will be anywhere from neutral to 20% heavier than water. The buoyancy factor aids in the handling of the pipe once in the water, which makes installation easier and faster in most applications.

## APT MD Series Piping Buoyancy Table

Pipe Model	Metal Ducting	Carrier Pipe	Water Displacement, Grams		Weight per Linear Foot, Grams - Empty		Weight per Linear Foot, Grams - w/ Fuel	
			Freshwater	Saltwater	Weight	Result	Weight	Result
XP-100-MD	MD-200	P-100-SC	871 (31 oz)	897 (32 oz)	869 (31 oz)	Neutral	984 (35 oz)	Sinks
XP-150-MD	MD-250	P-150-SC	1277 (43 oz)	1315 (46 oz)	1080 (38 oz)	Floats	1310 (46 oz)	Neutral
XP-175-MD	MD-250	P-175-SC	1277 (43 oz)	1315 (46 oz)	1186 (42 oz)	Floats	1505 (53 oz)	Sinks
XP-200-MD	MD-300	P-200-SC	1892 (67 oz)	1949 (69 oz)	1610 (57 oz)	Floats	2073 (73 oz)	Sinks
XP-100-MDD	MD-150	P-100-D	558 (20 oz)	575 (20 oz)	N/A	N/A	N/A	N/A
XP-150-MDD	MD-200	P-150-D	871 (31 oz)	897 (32 oz)	829 (29 oz)	Floats	1059 (37 oz)	Sinks
XP-175-MDD	MD-250	P-175-D	1277 (43 oz)	1315 (46 oz)	1008 (36 oz)	Floats	1327 (47 oz)	Neutral
XP-200-MDD	MD-300	P-200-D	1892 (67 oz)	1949 (69 oz)	1455 (51 oz)	Floats	1918 (68 oz)	Neutral

### Marina Sumps

Due to the increased environmental and fire hazards seen at marinas, FFS recommends aboveground or marina applications use stainless steel containment sumps. Check with all governing sources to ensure that the components used in your marina system are acceptable.

### MD Pipe Pulling

As with direct bury piping, when dispensing pipe from a reel, always pull MD pipe from the bottom of the reel.



**Warning** MD series piping is heavy, weighing about 2.8 pounds per foot for P-175-MD (a 500 foot reel of P-175-MD will weigh over 1400 pounds). Unreeling MD series pipe isn't as easy as unreeling single or double wall pipe due to both the weight of the pipe and its tendency to retract as it unreels. Stabilize the reel on solid ground during the pipe pulling process to help with these issues. In addition, FFS recommends using two workers to pull the pipe and two workers to supervise the reel while pulling the MD series pipe off of the reel.

Due to the process of pulling the product piping through the MD jacket at the factory, the MD ducting will stretch once on the reel. Make sure to cut your pipe length slightly longer to accommodate for any shrinkage (2-3% on average) after installation.

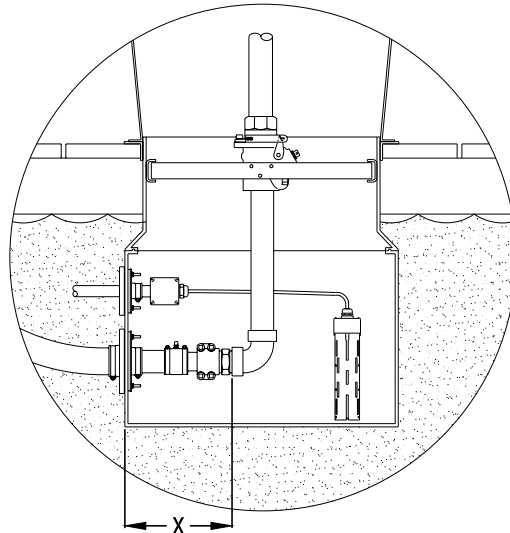

Figure 1

## Installation

### Preparing MD Pipe

MD pipe can be cut using a hacksaw, reciprocating saw or steel pipe cutters. Due to the helical nature of the galvanized steel layer, it can be difficult to get a square cut. It's important that the galvanized steel layer be square cut though to allow for the full clamping pressure to be applied around the metallic ducting outside of the sump.

As a general rule, the metal jacket needs to be stripped back approximately 8" from the end of the product pipe. For a more accurate cut, first determine the proper location of the riser sections inside of the sump and then measure from the end of the barbed fitting to the outside of the sump wall (see Figure 1 where X equals this measurement). This is done to obtain the proper watertight seal around the metallic ducting using the appropriate entry boot.

### Trimming Back MD Pipe

#### Option #1

To strip back the metal ducting, pull one end of the product pipe far enough away from the metallic duct to avoid cutting through the product pipe when trimming the MD duct. Using a hacksaw or **reciprocating saw**, cut through the metallic duct at the desired location. Use a file to smooth any jagged edges on the ducting left by this procedure.

#### Option #2

To strip back the metallic ducting, place a band clamp at the point to which you wish to strip back too. Using this band clamp as a guide, make a circumferential cut all the way around the MD ducting, cutting through the plastic cover. Make a longitudinal cut from the band clamp to the end of the pipe, and pull away the plastic cover. To cut away the exposed metal layer, use a nibbler or low-profile shear. The metal coils can be loosened somewhat by "unwinding" them, then can be cut with the snips. Use a file to smooth any jagged edges left by this procedure.

**Note:** After removing the metal jacket, be sure to inspect the product pipe for any damage. File and remove all sharp edges and corners from the metal jacket that might scrape or cut into the piping or entry boot.

**Note:** It is recommended and good practice to conduct an initial air test on the secondary layer while on dry land. You can refer to the testing procedures outlined in the APT installation guide for underground system.

## Sealing Pipe During Installation

During any installation of APT marina pipe that will be installed in or under water be sure to cap the ends of the primary pipe from water intrusion during installation.

- *If using an APT single wall MD system (XP-xxx-MDD), be sure to seal off the MD jacket and the product pipe from water intrusion during the installation.*
- *If using an APT secondarily contained MD system (XP-xxx-MD), be sure the SC jacket is sealed using a test boot prior to taking the pipe into the water, this will insure that water does not enter the interstitial layer of the SC product pipe. Again be sure to seal off the MD jacket and the product pipe from water intrusion during the installation.*

## Supporting MD Pipe

FFS piping connections are very strong and durable, but continual or repetitive high strain levels (as seen on marina applications) could cause fatigue and possible failure of the primary pipe connections. FFS requires that MD pipe be properly supported.

## Fixed Dock Installation

When installing MD series pipe to fixed docks, piping may be run on the side of the dock or underneath it. The following are some examples of what can be used as pipe supports attached to the dock (not all possibilities are listed): Unistrut conduit hangers, "U" bolts, PVC pipe couplers or Hosebuns.

FFS recommends that MD pipe be supported evenly along the entire run and fed through a three or four inch PVC pipe secured to the under side of the dock. This procedure allows the pipe to move in relationship to the changing water levels inside of the PVC pipe, so extensive strain is relieved from the piping. Prior to entering a containment sump, the ends of a MD piping run must be rigidly secured to the dock and mounted properly to the entry boots located on the sump wall. Supports are required every three feet on the piping run to eliminate any sag in the piping run.

## Floating Dock Installation

When installing MD series pipe under a floating dock, FFS recommends that the pipe be weighted down to keep it from moving freely during installation and coiled or looped underwater to compensate for any change in water levels. Weights such as sand bags or concrete forms connected by nylon or polypropylene rope and draped over the MD pipe can be use effectively. Please refer to Figures 2 & 3 for typical floating dock installation diagrams.



**MD pipe must never come in contact with concrete forms, if they are used. Support along the run of pipe should be designed to allow free travel of the pipe to accommodate expansion and contraction.**

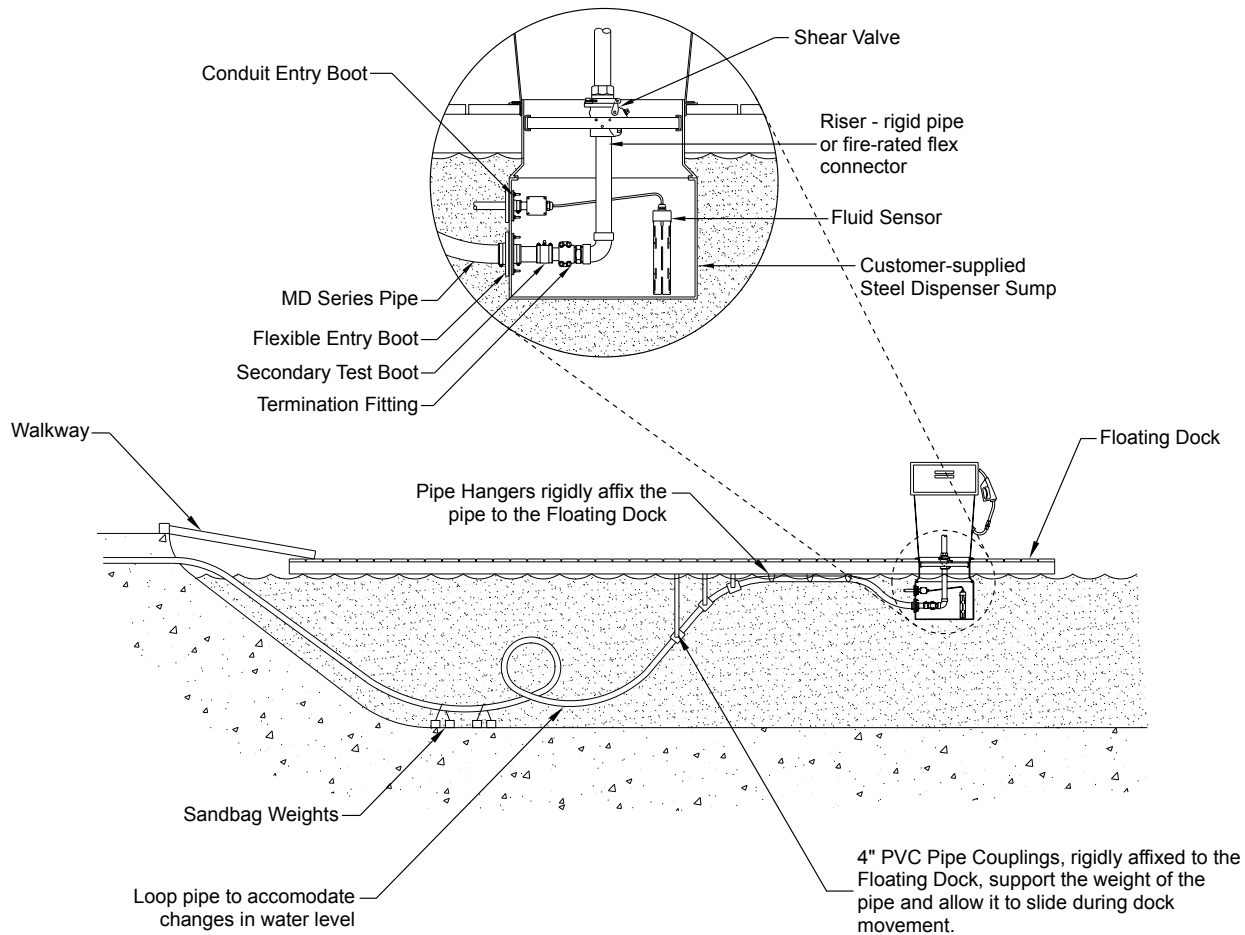

**Figure 2: Floating Dock Typical Install #1**

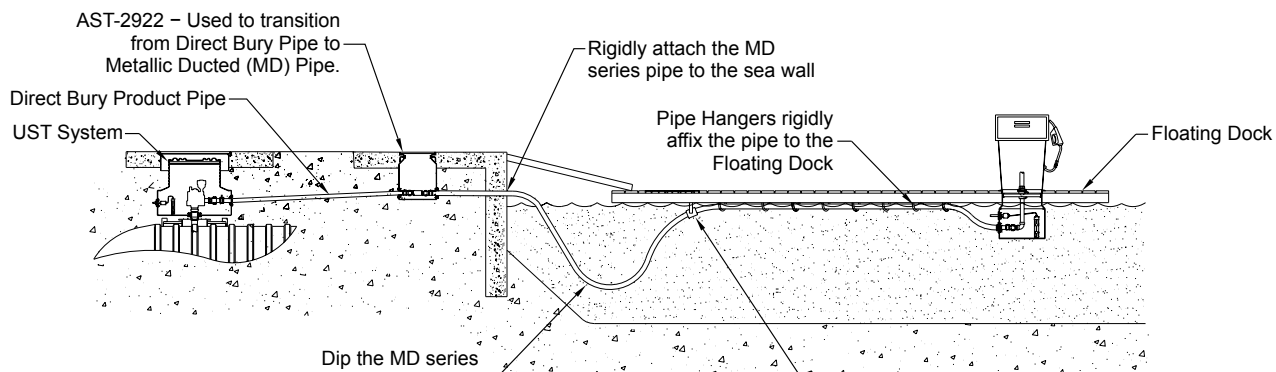

**Figure 3: Floating Dock Typical Install #2**



**Franklin Fueling Systems**

www.franklinfueling.com

3760 Marsh Road • Madison, WI 53718, U.S.A.  
 Tel: +1 608 838 8786 • Fax: +1 608 838 6433  
 Tel: USA & Canada 1 800 225 9787 • Tel: México 001 800 738 7610

**Franklin Fueling Systems GmbH**  
 Rudolf-Diesel-Strasse 20 • 54516 Wittlich, GERMANY  
 Tel: +49-6571-105-380 • Fax: +49-6571-105-510