



# QR-XP Clamshell Fittings

## Installation Instructions

**Warning**  XP piping must be installed in conjunction with XP fittings. Using P-series fittings with XP pipe will result in improper assembly and potential fitting failure.

**Warning**  Follow all federal, state and local laws governing the installation of this product and its associated systems. When no other regulations apply, follow NFPA codes 30, 30A and 70 from the National Fire Protection Association. Failure to follow these codes could result in severe injury, death, serious property damage and/or environmental contamination.

**Caution**  The part described in this document is one element of a system. All components of this system should be installed according to the manufacturer's specifications so that the system's integrity is not compromised. Test the complete system after installation according to all pertinent local, state and federal laws to ensure its proper operation. Failure to properly verify operation could lead to environmental contamination or system degradation.

**Important:** XP clamshell clamps are embossed "XP" and can be identified by their blue color.

### Installation Procedure

1. Place the gasket (not included) between the QR-XP fitting and the mating connection. Place the tri-clamp (not included) over the mating point, and secure it such that the fittings will not separate. To ensure a tight seal, torque the wing nut on the tri-clamp to a minimum of 25 in-lbs (2.82 N-m).
2. Square off and de-burr the end of the pipe. If you are using SC (Secondary Contained) piping, cut back the scuff guard layer to the sump wall (approximately 9" (23 cm) in dispenser sumps) and cut back the SC layer 4½" (11.5 cm). For further cutback details, see the process's complete description in the *DWC-XP-XXX Double Wall Cutter (SC) Installation Instructions* or in APT's *Installation Guide Overview*.
3. Push pipe through the appropriate entry boot in the sump wall and install the air test boot (if required), but do not tighten the air test boot at this time.
4. Push the pipe onto the barbed fitting until the end of the pipe is flush with the flange.
5. Apply a thin layer of petroleum jelly to the first two inches of the outside diameter of the pipe that will be covered by the clamp.
6. Place the drilled and tapped compression clamp halves onto the barbed fitting, making sure that the locking groove on the clamp is in the mating groove on the barbed fitting.
7. Insert two bolts with washers through the drilled clamp and thread them into the tapped clamp half. Please refer to the table below to determine the correct bolt for your fitting.

Fitting Size	Bolt Size & Type
1.00"	1/4" socket head
1.50" and 1.75"	3/8" hex head
2.00"	7/16" hex head

8. Using the appropriate tool, tighten the bolts (no more than one turn at a time) in an alternating pattern until the clamps are metal-to-metal.

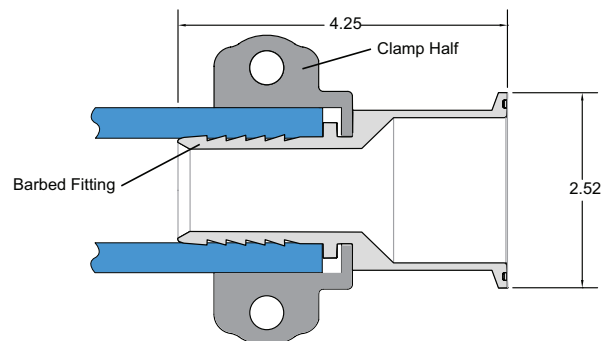

**Franklin Fueling Systems**

www.franklinfueling.com

3760 Marsh Road • Madison, WI 53718, U.S.A.

Tel: +1 608 838 8786 • Fax: +1 608 838 6433

Tel: USA & Canada 1 800 225 9787 • Tel: México 001 800 738 7610

**Franklin Fueling Systems GmbH**

Rudolf-Diesel-Strasse 20 • 54516 Wittlich, GERMANY

Tel: +49-6571-105-380 • Fax: +49-6571-105-510