



FE PETRO[®]
Franklin Fueling Systems

**INTELLIGENT SUBMERSIBLE TURBINE
VARIABLE FREQUENCY CONTROLLER**

IST-VFC

IST-VFC

Installation and Owner's Manual

Software Revision 1.4 and 1.5











Revision: SW3, Pole 5 – Off on Master for Alternating Lead Pump

Important Safety Messages

FE Petro equipment is designed to be used to pump volatile hydrocarbon liquids such as gasoline and diesel fuel. Installing or working on this equipment means working in an environment in which these highly flammable liquids are present. **This presents a risk of severe injury or death if these instructions and standard industry practices are not followed. Read and follow this entire instruction booklet before installing or working on this equipment.**

As you read these instructions, watch for the following safety symbols:

- Warning**  This symbol identifies a potentially hazardous situation which, if the instructions that follow it are not adhered to, could result in death or serious bodily injury.
- Caution**  This symbol identifies a potentially hazardous situation which, if the instructions that follow it are not adhered to, could result in serious property damage, including possible environmental contamination as a result of the leakage of fuel from the equipment.
-
- Warning**  **Voltage stored in the capacitor bank of the IST-VFC presents a risk of potentially lethal electrical shock even after power is disconnected. Wait 12 minutes after power disconnection before removing IST-VFC cover; this will allow stored voltage to dissipate.**
- Warning**  **This pump controller has two power supply connection points, one power to the controller and a second from the dispenser hook signal. Disconnect power to both connection points. Failure to do so risks a potentially lethal electrical shock.**
- Warning**  **Highly flammable vapors may be present in the environment in which this equipment is being installed or serviced. Do not smoke while working on or near this equipment. Use only non-sparking tools. Failure to follow this instruction could result in serious fire or explosion.**
- Warning**  **Many submersible pumps are now housed in containment sumps designed to trap hazardous liquid spills and prevent contamination of the environment. These containment sumps can also trap dangerous quantities of hydrocarbon vapors which, if inhaled, could lead to dizziness and fainting, or, if ignited, could result in an explosion causing serious personal injury or death. Before working in or entering a containment sump, always check for the presence of hydrocarbon vapors. If found to be unsafe, ventilate the sump with fresh air, then re-check the atmosphere in the sump before doing the work and periodically thereafter. ALWAYS have a second person standing by for assistance when working in or around a containment sump.**
- Warning**  **Follow all federal, state, and local laws governing the installation of this product and its associated systems. When no other regulations apply, follow NFPA codes 30, 30A, and 70 from the National Fire Protection Association. Failure to follow these codes could result in severe injury, death, serious property damage, and/or environmental contamination.**
- Warning**  **If the electrical circuit breakers are accidentally turned on while the Intelligent Submersible Turbine (IST) is being installed, electrical power could be applied to the IST, creating the risk of potentially lethal electrical shock hazard and the possibility of a spark which could ignite any hydrocarbon vapors present during IST installation and result in an explosion or fire. ALWAYS tag and lock breakers so they are not turned on accidentally.**

Note: Installing submerged fill pipes in the same manway cover as the submersible pump has been known to cause “air locking” of the submersible when the pump is operating during tank filling. This can cause air to enter the pipe line and can also cause the IST-VFC (if used) to indicate “Tank Empty”. Therefore, FE Petro does not recommend this practice.

Installer: This instruction booklet **MUST** be left with the owner of the service station at which the equipment is being installed.

Station Owner: Retain these instructions for future use and provide them to persons servicing or removing this equipment.

Note: The IST-VFC can be used with a PMA VS2 only; the PMA VS2 is different from that used on FE Petro's standard pumps (e.g., STP75 and STP150) and cannot be interchanged.

INSTALLATION INSTRUCTIONS

Note: Steps 1 through 3 overlap with the installation instructions that are packaged with the pump during shipping. This is done to ensure all instructions are available to those in need of them during installations. As a result, steps 1-3 may already be complete.

- 1) Connect the electrical conduit with approved fittings to the pump junction box.
- 2) Remove the pump junction box cover, and remove the compression seal by loosening the screw (do not remove the screw). The seal has four holes to accommodate a ground wire and three-phase power from the IST-VFC.

Warning  **Not installing a ground wire increases the risk of potentially lethal electrical shock and equipment failure. All holes of the compression seal (contractors plug) must be filled with wires or a celcon rod to enable it to seal.**

3a) Verify that the power is still OFF at the supply box. Pull four wires from the spot where the IST-VFC unit will be mounted (indoors) into the pump junction box (outdoors) and feed through the compression seal. Replace the compression seal and tighten in place securely. Connect the three wires from the connector assembly to the three phase power wires coming from indoors. Connect the fourth wire (ground) from inside to the pump junction box ground lug. All wiring must be done in accordance with the National Electrical Code (NEC).

3b) Replace the cover of the pump junction box and tighten in place securely.

Note: If the motor power wires are not connected with the proper polarity the motor will spin in reverse, causing pressure of approximately half that of the normal operation (see step 9c).

Warning  **The compression seal is not intended to replace the vapor explosion seals required by the NEC. All materials used between the power supply box and the submersible pump junction box must be gasoline and oil resistant. All wiring used within the IST-VFC must be rated 90°C, 300V minimum. Failure to comply with these, and all applicable NEC guidelines, could result in an unsafe installation.**

Note: The IST-VFC measures 12"H x 6"W x 9"D. To allow room for field adjustments and air clearance, mount the controllers so they have 6" or more of right side (cover side) clearance, and 3" or more left side (heat sink side) clearance. Install with the heat sink fins vertical and the knock-outs down.

Note: The IST-VFC should be mounted indoors at indoor temperature not exceeding 95° F.

4a) Hang the IST-VFC on a vertical surface and remove the two front panel screws and front cover. Install approved electrical conduits only at knockouts on the bottom of the IST-VFC enclosure.

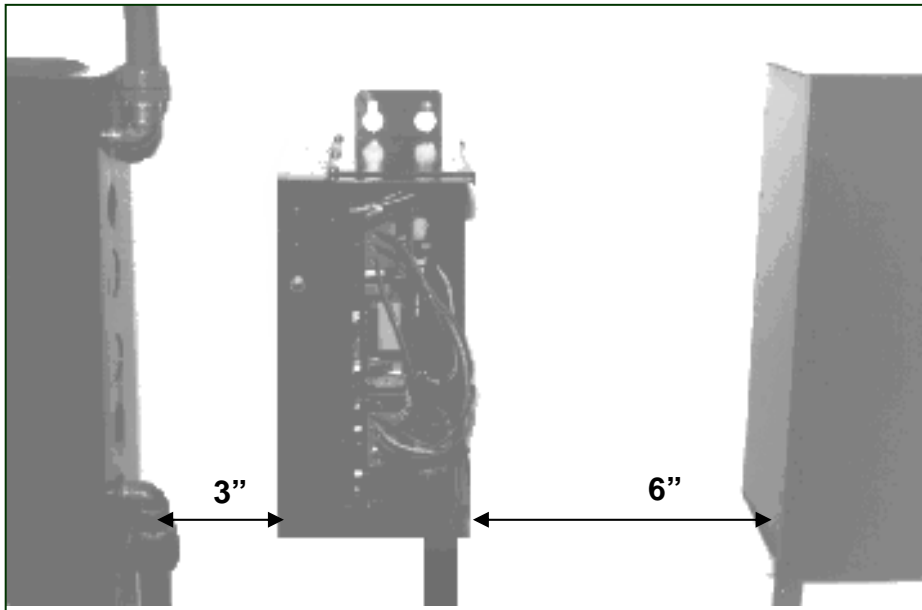

Photograph 1

4b) Per Figure 1, connect the three motor control wires from the pump junction box to labeled terminals near the bottom of the IST-VFC circuit board observing color coding of wires (B-B, O-O, R-R). Connect the ground wire from the submersible pump to the ground lug on the IST-VFC circuit board. Secure wires away from circuit board components using the wire clamp attached to enclosure.

Note: Interference is created by several types of equipment in a station (Submerged Pumps, Fluorescent Lighting, Compressor, etc.), some more than others; this interference can affect the operation of more sensitive equipment (such as tank monitors and electronic line leak detectors) which communicate through data lines. When installing the IST-VFC, FE Petro recommends that the power wires from the Power Source as well as the power wires to the IST or STP units with VS2 suffix (pump) be in their own steel conduit which is not broken or routed through race ways. FE Petro also recommends that all equipment be installed per the manufacturer requirements for best results.

DO NOT INSTALL IN OR OVER HAZARDOUS LOCATION
USE ONLY WITH FE PETRO PMA MODEL PMA-VS2

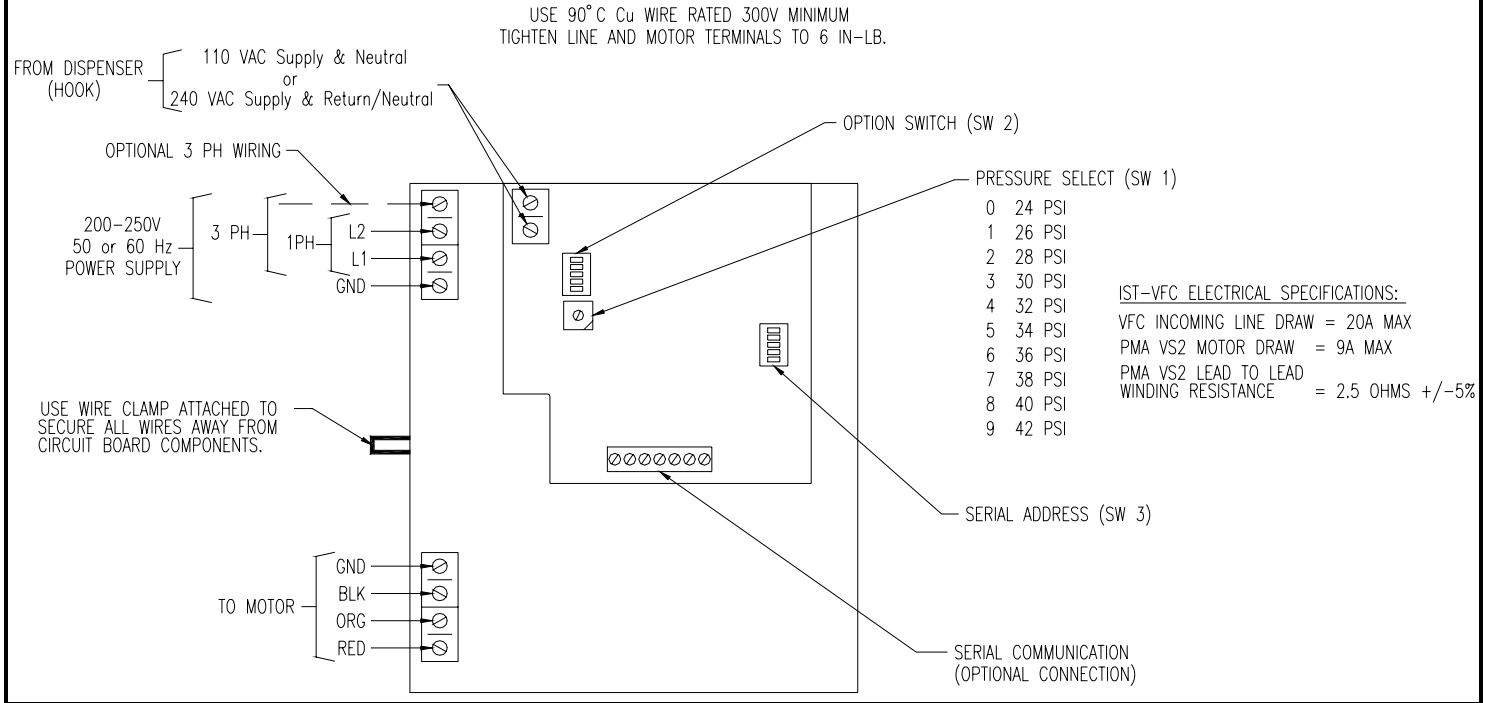

Figure 1

Note: Dispenser hook terminals are capable of accepting either 110 VAC or 240 VAC dispenser signals. The dispenser hook terminals require a signal wire from the dispenser and a Neutral/Return.

Warning ⚠️ **To avoid the risk of potentially lethal electrical shock, fire, or explosion, always tag and lock circuit breakers in the off position before opening the IST-VFC.**

Warning ⚠️ **Voltage stored in the capacitor bank of the IST-VFC presents a risk of potentially lethal electrical shock even after power is disconnected. Wait 12 minutes after power disconnection before removing the IST-VFC cover; this will allow stored voltage to dissipate.**

4c) Connect single or three phase, 200-250V, 50 or 60Hz power supply to terminals as detailed in Figure 1 (three phase power is recommended if available). Single-phase power is connected to L1 and L2; three-phase power is connected to L1, L2 and L3. Secure wires away from circuit board components using the wire clamp attached to the enclosure. Reference Figure 1 for wiring detail.

4d) Connect dispenser hook signal to the two position terminal strip on the IST-VFC board as detailed in Figure 1. Secure wires away from circuit board components using the wire clamp attached to enclosure.

OPTION SELECT SWITCH SETTINGS

5) **OPTION SELECT SWITCH - (SW2)** (See FIGURE 1)

Pole 1

Pole 1 allows for pre-start conditions of Mechanical Line Leak Detection (MLD) and some Electronic Line Leak Detection (Veeder-Root).

Pole 1 set to **ON (factory setting)**

For the first 6 seconds the IST is turned on, the pump will operate at approximately 34 psi, unless the operating pressure is set above this (Position 5 or higher in the rotary switch SW1).

Pole 1 set to **OFF (Veeder-Root Setting)**

For the first 6 seconds the IST is turned on, the pump will operate at approximately 8 psi higher pressure than the set operating pressure. Position 9 on the rotary switch (SW1) operates at 40 psi, which is the same as Position 8 on the rotary switch (SW1).

Note: When (SW2) Pole 1 is OFF, positions 8 and 9 on the rotary switch (SW1) set the operating pressure to 40 psi (required for Veeder Root PLLD installations).

Factory Setting	<i>Pole 1 (Top)</i>	<i>Function</i>
	ON	6 second increase in pressure up to pressure setting range of 34 psi
	OFF	8 psi increase in pressure for 6 second throughout pressure setting range

Table 1

Pole 2

Pole 2 selects what type of product you will be pumping; **Pole 2 is factory set to Gasoline.**

Factory Setting	<i>Pole 2</i>	<i>Product Type</i>
	ON	Gasoline
	OFF	Diesel

Table 2

Note: Because gasoline has a different specific gravity than diesel fuel, the correct setting of Pole 2 is important to ensure that the IST-VFC regulates flow to the desired level.

Pole 3

Pole 3 is factory set to the OFF position, and should only be turned ON in the Master of a Master-Slave or Master-Slave/Alternating Circuit configuration. The Master-Slave Control Connections section of this manual provides operation and wiring details.

Factory Setting	<i>Pole 3</i>	<i>Configuration</i>
	ON	<u>Master</u> of a Master-Slave or Master-Slave/Alternating Circuit configuration
	OFF	Normal stand-alone operation or: Slave of a Master-Slave configuration Slave of a Master-Slave/Alternating Circuit configuration

Table 3

Note: When working with a Master-Slave or Master-Slave/Alternating Circuit configuration, there can only be one Master and up to (15) slaves.

Poles 4 and 5

Poles 4 and 5 together select one of four levels of pressure compensation for different piping restrictions. **The least restrictive piping run is selected at the factory and this setting will be desirable for most applications.** Prior to changing these settings, refer to the “IST-VFC CALIBRATION” section.

	Compensation	Pole 4	Pole 5	Piping Configuration
Factory Setting	0	ON	ON	least restrictive
	1	ON	OFF	...
	2	OFF	ON	...
	3	OFF	OFF	most restrictive

Table 4

Note: An example of a small restriction piping system would be 2” fiberglass running less than 150’. An example of a restrictive piping system would be 1 1/2” convoluted flexible piping greater than 75’ in length.

Note: When working with a Master-Slave or Master-Slave/Alternating Circuit configuration, the piping compensation must be identical in all controllers.

- 6a) Replace the cover of the IST-VFC.
- 6b) Insert a 0-100 psi pressure gauge into the 1/4” line test port of the submerged pump (or other pressurized test location in the piping system).
- 6c) Begin purging the air from the piping system by activating a dispenser handle and pumping product into an approved container; the green light on the IST-VFC should flash when the pump is running. Verify that while the pump is on but no product is being dispensed the pressure reading on the gauge is equal to the related pressure from Table 6 in step 9c. (+5/-7 psi).

Note: If pressure in the piping system is much lower than selected, it is possible that the polarity of the motor power wires is not correct, causing the motor to spin backwards. Install a pressure gauge in the line test port, turn on the pump, and read the pressure gauge. Turn off the pump at the power supply, and change the connection of any two wires at the pump or at the IST-VFC motor terminals. Turn the pump back on and read the pressure gauge again. The electrical connection, which gives the higher reading on the pressure gauge, is the correct one.

- 6d) Complete purging the remaining air from the piping system and dispensers. If using Master-Slave or Master-Slave/Alternating Circuit, continue with next section. If not, go to “IST-VFC CALIBRATION” section.

MASTER-SLAVE CONTROL CONNECTIONS

Note: When using multiple VFC's (Master-Slave(s)), the software must be of the same revision.

Warning  **To avoid the risk of potentially lethal electrical shock, explosion or fire, always tag and lock circuit breakers in the off position before removing the cover of the IST-VFC.**

Warning  **Voltage stored in the capacitor bank of the IST-VFC presents a risk of potentially lethal electrical shock even after power is disconnected. Wait 12 minutes after power disconnection before removing the IST-VFC cover; this will allow stored voltage to dissipate.**

7a.) When two IST pumps or STP units with VS2 suffix are installed to be run in parallel discharging into the same line to provide a large total flow, it is desirable to make a Master-Slave connection. In this configuration, the slave unit(s) will run only when requested to do so by the master unit. Master-Slave connections are made through the RS485 terminals at the bottom of the small circuit board. Figure 2 shows the small circuit board connections as supplied by the factory (resistors required are supplied by FE Petro). Figure 3 details how to connect for a Master-Slave application.

Another feature of the Master-Slave connection is the ability to have a Slave take command for product delivery if there is a problem with the Master. If certain abnormal conditions occur in the Master of a Master-Slave configuration, the Master will relinquish control to a Slave so that product delivery can continue. If any of the following conditions are present in the Master, a Slave will take control:

- Tank Empty
- Locked Rotor in PMA
- Capacitor Failure in IST-VFC
- High Temperature in IST-VFC

Note: With SW2 Pole 1 in the OFF position, the Master will not relinquish control to the Slave(s).

7b) Set option select switch (SW2) pole 3 to the **ON position for the Master** IST-VFC and **OFF for the Slave(s)** IST-VFC as shown in figure 3; Verify that all switches of serial address (SW3) are set per TABLE 5.

7c) Connect the master IST-VFC to the slave(s) IST-VFC as detailed in figure 3. Wire per NFPA 30A, and NFPA 70. For the signal wires, use 18 AWG 3 conductor cable (300V minimum), with conductors twisted and within a common jacket. Cut wires to length so that there is no excess wiring touching circuit board components.

Note: When wiring a master-slave set, connect signal from dispenser to the terminals of the master IST-VFC only. The master will energize the slave(s) when needed without a signal from the dispenser.

7d) When all connections are complete, reinstall the IST-VFC covers and activate supply power. Verify that the front panel green light is on for both Master and Slave(s) IST-VFC. To confirm proper operation of the Master-Slave connection, press the reset switch on the front panel of the Master IST-VFC. The Master should reset all slaves.

MASTER-SLAVE/ALTERNATING CIRCUIT FEATURE

- 8a) You may choose to add the Alternating Circuit feature to a Master-Slave configuration. The Alternating Circuit feature continuously alternates the lead pump at the beginning of each pumping cycle. In other words, it will turn on a different pump each time all dispensers are shut off and at least one dispenser is turned back on.
- 8b) To enable the Alternating Circuit feature, set (SW3) pole 5 on the Master IST-VFC to the **OFF** position. Serial Address (SW3) on the slave(s) IST-VFC(s) should be set per Table 5.

SW3						
Address	Pole -1	Pole -2	Pole -3	Pole -4	Pole-5 on M-S /AC	Pole-5 on M-S /AC
Master-0	Off	Off	Off	Off	On	Off
Slave-1	Off	Off	Off	On	On	On
Slave-2	Off	Off	On	Off	On	On
Slave-3	Off	Off	On	On	On	On
Slave-4	Off	On	Off	Off	On	On
Slave-5	Off	On	Off	On	On	On
Slave-6	Off	On	On	Off	On	On
Slave-7	Off	On	On	On	On	On
Slave-8	On	Off	Off	Off	On	On
Slave-9	On	Off	Off	On	On	On
Slave-10	On	Off	On	Off	On	On
Slave-11	On	Off	On	On	On	On
Slave-12	On	On	Off	Off	On	On
Slave-13	On	On	Off	On	On	On
Slave-14	On	On	On	Off	On	On
Slave-15	On	On	On	On	On	On

Table 5

Caution  **Line leak detection performance can be affected when using multiple IST-VFC's.**

Note: FE Petro improved the communication capability of the IST-VFC with the release of software version 1.4, which added an alternating lead pump option. Therefore, to ensure proper communication in a given system, all IST-VFC's must be of software revisions prior to 1.4 (e.g. 1.2, 1.3) or revisions 1.4 or later. The software revision can be determined by reading the label on the microprocessor chip, which is located on the upper (smaller) printed circuit board.

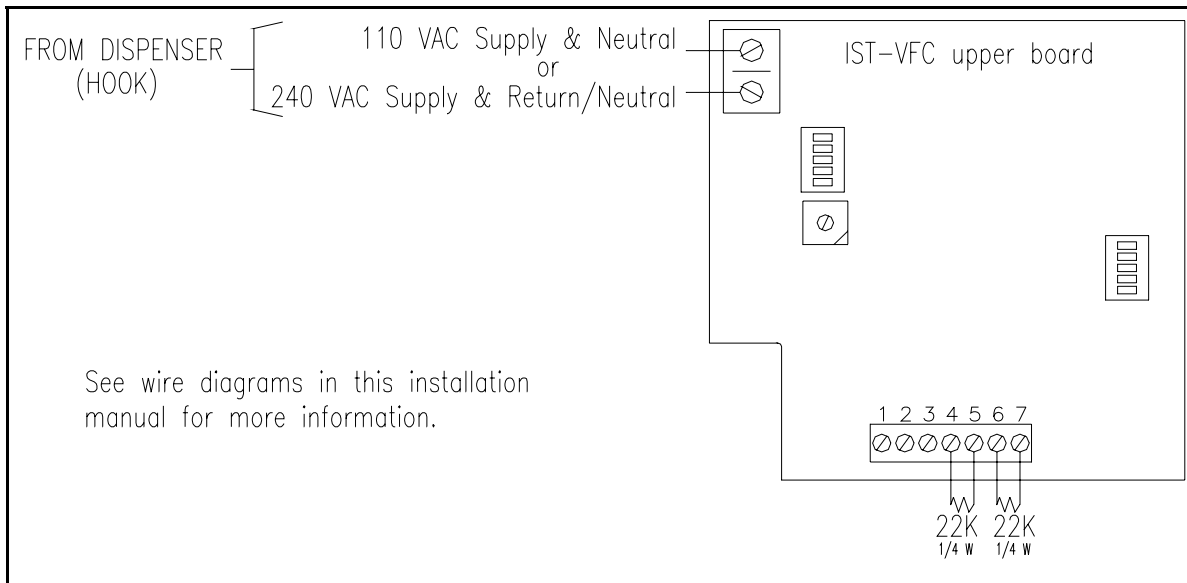

Figure 2

Note: Dispenser hook terminals are capable of accepting either 110 VAC or 240 VAC dispenser signals. The dispenser hook terminals require a signal wire from the dispenser and a Neutral/Return.

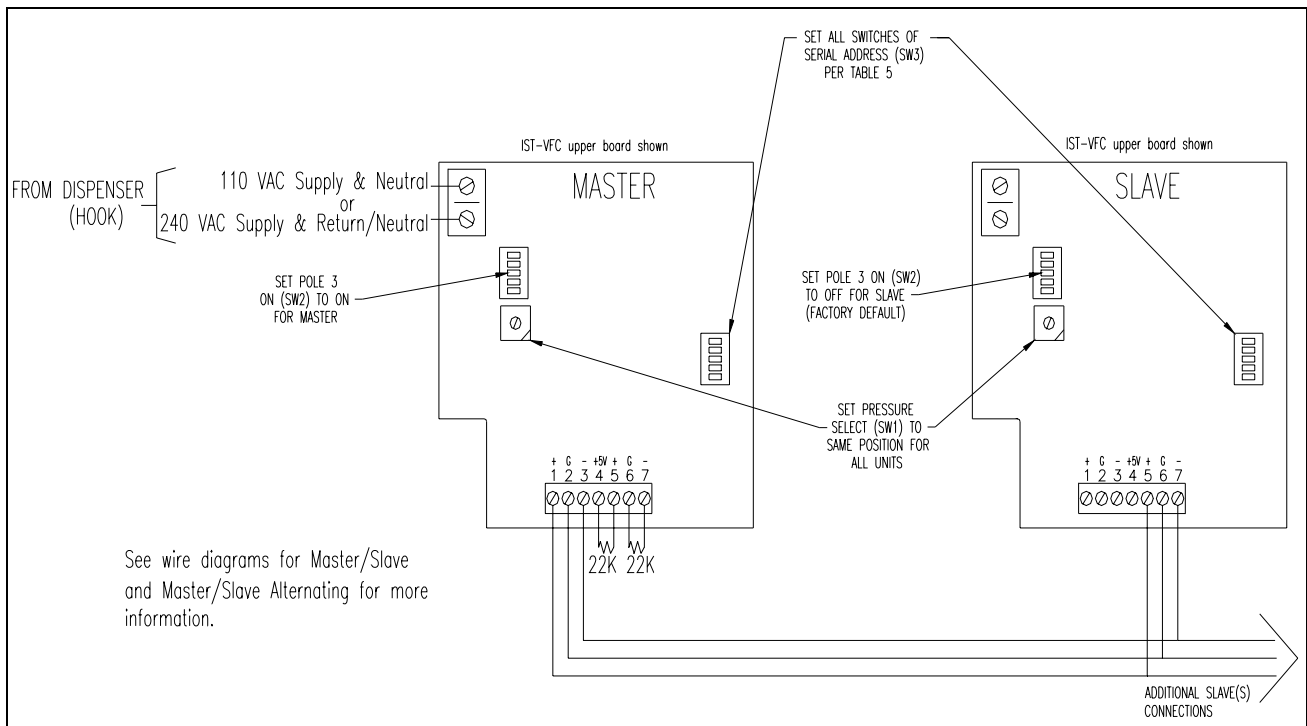



Figure 3

IST-VFC CALIBRATION

- 9a) Verify rotary switch on IST-VFC is set to position 4. This will provide approximately 32 psi output from the IST or STP units with VS2 suffix, and serves as a good starting point for IST-VFC calibration.
- 9b) Using a 5 gallon capacity minimum approved container, go to the dispenser closest to the storage tank and perform a gallons per minute (GPM) test. If the product being pumped is gasoline, consider following the EPA Fuel Dispenser Flow Rate Test Procedure (for 10 GPM maximum flow rate standard).

Note: It is necessary to perform a gallon per minute (GPM) test for each product available at the dispenser. This will confirm that all product outputs, including products blended at the dispenser, do not exceed desired levels.

Warning  **To avoid the risk of potentially lethal electrical shock, explosion or fire, always tag and lock circuit breakers in the off position before removing the cover of the IST-VFC.**

Warning  **Voltage stored in the capacitor bank of the IST-VFC presents a risk of potentially lethal electrical shock even after power is disconnected. Wait 12 minutes after power disconnection before removing the IST-VFC cover; this will allow stored voltage to dissipate.**

- 9c) If output is above or below the desired range (i.e. 8-10 GPM), remove the IST-VFC cover and adjust the rotary switch (SW1), see Figure 1. This switch will increase or decrease the system operating pressure according to Table 6. An increase in pressure will normally yield an increase in flow rate; a decrease in pressure will reduce flow rate. Replace the IST-VFC cover and re-apply input voltage. Return to step 9b above and check GPM with the new settings. Repeat until the output obtained is within your desired range in GPM.

<i>Switch Position</i>	<i>Pressure</i>
0	24 psi
1	26 psi
2	28 psi
3	30 psi
4	32 psi
5	34 psi
6	36 psi
7	38 psi
8	40 psi
9	42 psi

Factory Setting

Table 6

Note: Additives in gasoline can change the specific gravity of gasoline, which may cause the pressures stated in the above table to vary.

Note: Rotary switch (SW1) on the Master of a Master-Slave or Master-Slave/Alternating Circuit configuration selects pressure setting for all slaves.

- 9d) Verify Pipe Compensation settings from Table 4 are optimized by doing another GPM test; this time with two other nozzles from the same product open at the same time as your test nozzle. If output falls from your desired range with three nozzles open, increase to the next highest compensation setting (0 to 1 or 1 to 2 for example). If output exceeds your desired range, decrease to the next lowest compensation setting (2 to 1 or 1 to 0 for example). Repeat this step until compensation setting is optimal for your installation.

Note: Use of 10 GPM “flow restrictors” to control a maximum flow rate of 10 gpm per nozzle (as required by the U.S. EPA) are not required if the variable frequency controller is properly calibrated as defined in “IST-VFC CALIBRATION” section.

TROUBLESHOOTING GUIDE

To aid field service personnel the IST-VFC is equipped with a microprocessor control that makes it possible for the unit to diagnose abnormal operating conditions, and communicate them via the LEDs on the front panel. The following is a definition of all operation and abnormal operating codes.

Green light on steady Power is applied to the IST-VFC.

Green light flashing Pump Motor Assembly (PMA) is running

Note: If the green light stays steady, even when a dispenser is energized, double check dispenser signals terminal on IST-VFC. Verify there is 115-240V between the two terminals for the hook, per Figure 1.

If the green light remains steady and the power to the “HOOK” connector has been verified, call FE Petro Technical Service for assistance.

If the green light constantly flashes, even when all the dispensers are turned off, there may be some power still applied to the IST-VFC Hook Connector. If this condition exists call FE Petro Technical Service for assistance.

Red light flashing Abnormal condition. Determine the number of flashes and refer to the appropriate row on the guide below.

Warning  **Voltage stored in the capacitor bank of the IST-VFC presents a risk of potentially lethal electrical shock even after power is disconnected. Wait 12 minutes after power disconnection before removing the IST-VFC cover; this will allow stored voltage to dissipate.**

<i>Flashes</i>	<i>Condition</i>	<i>Potential Causes</i>	<i>Proposed Action</i>
1	Under-load (Tank Empty)	Low fuel level in the storage tank	<ol style="list-style-type: none"> 1. Push reset button on the IST-VFC (Variable Frequency Controller). 2. If condition is corrected, check for proper operation of system; if operating correctly, do not continue to next step. If condition is still present continue to next step. 3. Check fuel level in storage tank; schedule fuel delivery, when delivery is complete and fuel level is above PMA end bell, push reset button on IST-VFC. Check for correct system operation.
2	Low Incoming Voltage	Voltage fluctuations or low input voltage.	<ol style="list-style-type: none"> 1. Push reset button on the IST-VFC. 2. If condition is corrected, check for proper operation of system; if operating correctly, do not continue to next step. If condition is still present continue to next step. 3. Use AC voltmeter to verify incoming voltage is within the 200-250VAC acceptable range. If voltage is not within this range, contact an electrician to correct problem.

Warning  **Voltage stored in the capacitor bank of the IST-VFC presents a risk of potentially lethal electrical shock even after power is disconnected. Wait 12 minutes after power disconnection before removing the IST-VFC cover; this will allow stored voltage to dissipate.**

<i>Flashes</i>	<i>Condition</i>	<i>Potential Causes</i>	<i>Proposed Action</i>
3	Locked Rotor	Foreign material in PMA or defective PMA.	<ol style="list-style-type: none"> 1. Push reset button on the IST-VFC. 2. If condition is corrected, check for proper operation of system; if operating correctly, do not continue to next step. If condition is still present continue to next step. PMA Inspection 3. Disconnect input voltage at load center, lock and tag circuit breakers.

<i>Flashes</i>	<i>Condition</i>	<i>Potential Causes</i>	<i>Proposed Action</i>
			<p>4. Remove two 9/16" bolts from extractable portion of the manifold. Disengage the 3/4" securing bolt of the electrical connector and swing out of the way.</p> <p>5. Pull extractable part of the pump. Note: Pump Motor Assembly shell can be damaged by blows from hard surfaces; use care in removing it.</p> <p>6. Remove black end cap from PMA and attempt to spin rotor with a 3/16" Allen wrench to determine if there's any binding. If binding or physical damage, continue with next step. If no binding or physical damage to the PMA and it is a new installation, reinstall extractable. Turn on the power to the IST-VFC unit and verify correct system operation. If condition is corrected, do not continue to the next step. If condition is still present, remove the extractable (repeat Steps 3, 4, and 5) and continue to the next step. Note: PMA can have a locked rotor during startups if it has been exposed to a corrosive environment, such as a tank ballasted in water.</p> <p>7. Remove four 5/16" cap screws that connect the PMA with 1/4" Allen wrench and remove the PMA from the motor discharge head. Note: Prior to mounting a new PMA, check lead assembly (wires inside the extractable portion to PMA) for shorted wires which may have caused the condition.</p> <p>8. Replace with a new variable speed (PMA VS2) pump motor. Note: Pump motor shell can be damaged by blows from hard surfaces; use care in replacing.</p> <p>9. Re-install extractable and secure by following reverse order of disassembly.</p> <p>10. Turn on power to the IST-VFC unit and verify correct system operation.</p>

Note: In rare installations a partial short can result from a nick in one of the pump power wires coupled with water in the electrical conduit from the IST-VFC to the pump. This condition is not a direct short, so the IST-VFC does not flash short circuit (six flashes). Instead, the IST-VFC will see this condition as abnormally high power consumption, and flash locked rotor (three flashes).

Warning  Voltage stored in the capacitor bank of the IST-VFC presents a risk of potentially lethal electrical shock even after power is disconnected. Wait 12 minutes after power disconnection before working inside the IST-VFC enclosure; this will allow stored voltage to dissipate.

<i>Flashes</i>	<i>Condition</i>	<i>Potential Causes</i>	<i>Proposed Action</i>
4	Open circuit (IST-VFC to motor)	Connection broken from IST-VFC to PMA	<p>1. Push reset button on the IST-VFC.</p> <p>2. If condition is corrected, check for proper operation of system; if operating correctly, do not continue to next step. If condition is still present continue to next step.</p> <p>IST-VFC/PMA Connections</p> <p>3. Disconnect power at load center, lock and tag circuit breakers.</p> <p>4. Remove the three motor control outputs from the IST-VFC unit.</p>

<i>Flashes</i>	<i>Condition</i>	<i>Potential Causes</i>	<i>Proposed Action</i>
			<ol style="list-style-type: none"> 5. Using an ohmmeter on 200 setting, place leads between these three wires of the pump motor, this is the first step in determining where the open circuit has occurred. Correct reading between any two of the three wires should be 2.5 +/-1 ohms. Continue conductivity tests on the remaining combinations of wires (3 total). Note results, e.g. Black to red = 3 ohms. Readings between any of the three motor control wires and ground should be an open circuit. If readings in this step are incorrect go to step 6; if readings are correct, contact FE Petro Technical Support for assistance. 6. Go to the submerged turbine and remove the cover at the top of the extractable manifold; remove the three wire nuts. 7. Place an ohmmeter between the three wires leading to the pump motor as above. If readings are incorrect go to PMA replacement in 3 flashes section; if readings are correct, there is problem with the wiring between the IST-VFC and this point. 8. Remove the junction box cover and do conductivity test on wires from junction box to extractable discharge head. If wires are not conducting replace the male and female connectors of the submerged turbine (p/n 400200930). If there is no problem with these connections the wires from the IST-VFC to the submerged turbine are suspect. Contact an electrician to correct the problem. 9. After the problem has been corrected turn on power to IST-VFC and verify system is operating correctly.
5	Capacitor bank	Bad IST-VFC capacitor bank	<ol style="list-style-type: none"> 1. Push reset button on the IST-VFC. 2. If fault condition still exists, replace IST-VFC unit. 3. If fault is cleared observe the IST-VFC in normal operation for approximately 10 minutes to see if it functions normally. If error resurfaces, replace IST-VFC.

Warning  Voltage stored in the capacitor bank of the IST-VFC presents a risk of potentially lethal electrical shock even after power is disconnected. Wait 12 minutes after power disconnection before removing the IST-VFC cover; this will allow stored voltage to dissipate.

<i>Flashes</i>	<i>Condition</i>	<i>Potential Causes</i>	<i>Proposed Action</i>
6	Short circuit	Short in connections from IST-VFC to PMA	<ol style="list-style-type: none"> 1. Push reset button on the IST-VFC. 2. If condition is corrected, check for proper operation of system; if operating correctly do not continue to next step. If fault is still present continue to next step. <p>IST-VFC/PMA Connections</p> <ol style="list-style-type: none"> 3. Disconnect power at load center, lock and tag circuit breakers. 4. Remove the three motor control outputs from the IST-VFC unit. 5. Using an ohmmeter on 200 setting, place leads across any two of the three wires of the pump motor. Correct reading between any two of the three wires should be 2.5 +/-1 ohms. Continue conductivity tests on the remaining combinations (3 total). Readings between any of the three motor control wires and ground should be greater than 80k ohms. If readings are incorrect proceed to step 6. If readings are correct, the possibility of a short circuit in the connections from the IST-VFC to PMA still exists. Contact

Flashes	Condition	Potential Causes	Proposed Action
			<p>FE Petro Technical Support for additional troubleshooting assistance.</p> <ol style="list-style-type: none"> 6. Go to the submerged turbine and remove the cover at the top of the extractable; remove the three wire nuts. 7. Place an ohmmeter between the three wires leading to the pump motor as above. If wires are shorted go to PMA replacement in 3 flashes section; if readings are correct there is problem with the wiring between the IST-VFC and this point. 8. Remove the junction box cover and do conductivity test on wires from junction box to extractable discharge head. If wires are shorted to ground or each other, replace the male and female connectors of the submerged turbine (p/n 400200930). If there is no problem with these connections the wires from the IST-VFC to the submerged turbine are suspect. Contact an electrician to diagnose and correct the problem. 9. After the problem has been corrected turn on power to the IST-VFC and verify system is operating correctly.
7	High Temperature	Excessive operation temperature in IST-VFC	<ol style="list-style-type: none"> 1. Check excessive heat in area where control box is mounted. 2. Verify all louvers for ventilation are free from obstruction. Remove obstruction and cycle power to reset IST-VFC. 3. If neither of these conditions exist, replace IST-VFC unit.
Glowing Steady	Electronics Failure	Defective circuit component	<ol style="list-style-type: none"> 1. Push reset on the IST-VFC. 2. If fault is still present, replace IST-VFC unit.

Contact FE Petro for additional troubleshooting information at 1-800-225-9787.



FE PETRO[®]
Franklin Fueling Systems

3760 Marsh Road • Madison, WI 53718 U.S.A.
Tel: +1 608 838 8786 • Fax: +1 608 838 6433 • www.franklinfueling.com
Tel: USA & Canada 1 800 225 9787 • Tel: Mexico 001 800 738 7610