

# *MagVFC*

*Mag* VARIABLE FREQUENCY CONTROLLER









## Installation and Owner's Manual



# Important Safety Messages

FE Petro equipment is designed to be used to pump volatile hydrocarbon liquids such as gasoline and diesel fuel. Installing or working on this equipment means working in an environment in which these highly flammable liquids are present. **This presents a risk of severe injury or death if these instructions and standard industry practices are not followed. Read and follow this entire instruction booklet before installing or working on this equipment.**

As you read these instructions, watch for the following safety symbols:

- Warning**  This symbol identifies a potentially hazardous situation which, if the instructions that follow it are not adhered to, could result in death or serious bodily injury.
- Caution**  This symbol identifies a potentially hazardous situation which, if the instructions that follow it are not adhered to, could result in serious property damage, including possible environmental contamination as a result of the leakage of fuel from the equipment.
- 
- Warning**  Follow all federal, state, and local laws governing the installation of this product and its associated systems. When no other regulations apply, follow NFPA codes 30, 30A, and 70 from the National Fire Protection Association. Failure to follow these codes could result in severe injury, death, serious property damage and/or environmental contamination.
- Warning**  ALWAYS tag and lock breakers so they are not turned on accidentally. If the electrical circuit breakers are accidentally turned on while the pump is being installed or serviced, electrical power could be applied to the pump, creating the risk of a potentially lethal electrical shock hazard and the possibility of an explosion or fire from a spark which could ignite hydrocarbon vapors present during IST installation.
- Warning**  After disconnecting power to the *MagVFC*, wait one minute after LED display blanks before opening the cover for servicing. Voltage stored in the capacitor bank of the *MagVFC* presents a risk of potentially lethal electrical shock even after power is disconnected.
- Warning**  Do not smoke while working on or near this equipment. Use only non-sparking tools. The environment in which this equipment is being installed or serviced may have highly flammable vapors present. Failure to follow this instruction could result in serious fire or explosion.
- Warning**  Before entering a containment sump check for the presence of hydrocarbon vapors. If hydrocarbon vapors are at unsafe levels, ventilate the sump with fresh air, re-check the atmosphere before entering the sump and periodically thereafter. ALWAYS have a second person standing by for assistance when working in or around a containment sump. Many submersible pumps are now housed in containment sumps designed to trap hazardous liquid spills and prevent contamination of the environment. These containment sumps can also trap dangerous amounts of hydrocarbon vapors which, if inhaled, could lead to dizziness and fainting, or, if ignited, could result in an explosion causing serious personal injury or death.
- Warning**  Always disconnect both power supplies (the 110-240 VAC from dispenser hook signals and the 200-250 VAC input power supply) before installing or servicing this system. Failure to do so could result in death or serious bodily injury.

**Installer:** This instruction booklet MUST be left with the owner of the service station at which the equipment is being installed.

**Station Owner:** Retain these instructions for future use and provide them to persons servicing or removing this equipment.

**Note:** Always reference the *Installation and Owner's Manual* that came with the equipment for the most current and complete list of installation and safety precautions. Where applicable, this manual may also contain notations on equipment features present in software version 1.14 and higher.

**Field Wire Panel Is the Right Side Panel Located Under the MagVFC Cover**

DO NOT INSTALL IN HAZARDOUS LOCATION  
 USE ONLY WITH FE PETRO PMA MODEL PMA VS2 & PMA VS4

USE 90°C Cu WIRE RATED 300V MINIMUM  
 TIGHTEN LINE AND MOTOR TERMINALS TO 8 IN-LB.

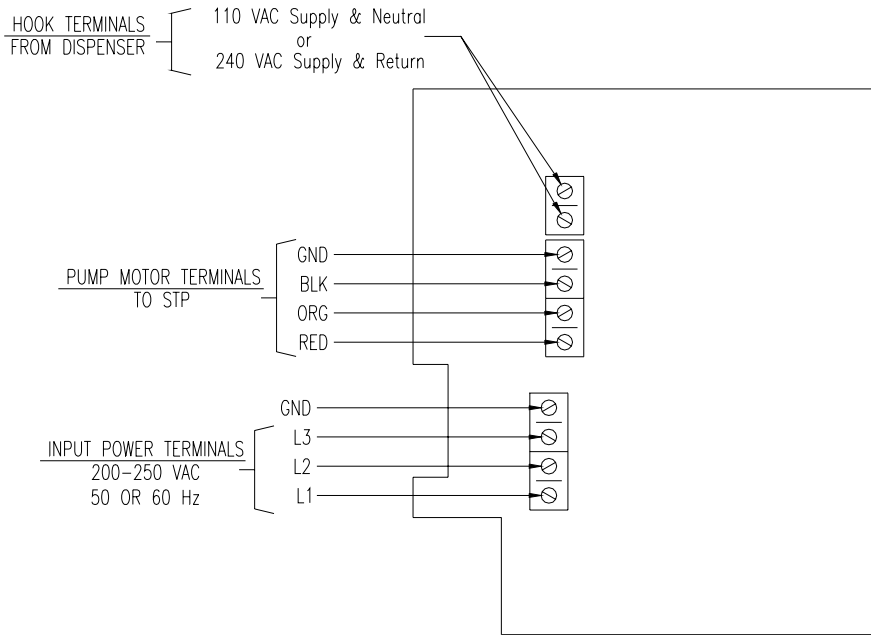

MagVFC ELECTRICAL SPECIFICATIONS:

MagVFC INCOMING LINE DRAW:  
 SINGLE PHASE INPUT = 18A MAX  
 THREE PHASE INPUT = 20A MAX

PMA VS4 MOTOR DRAW = 15A MAX  
 PMA VS4 LEAD TO LEAD  
 WINDING RESISTANCE = 1.2 OHMS +/-1 OHM

PMA VS2 MOTOR DRAW = 9A MAX  
 PMA VS2 LEAD TO LEAD  
 WINDING RESISTANCE = 2.5 OHMS +/-1 OHM

NOTE: INCOMING POWER MUST BE THREE PHASE  
 TO ACHIEVE OPTIMUM PERFORMANCE OF VS4.

**Figure 1**

**Hook Terminals:** Voltage signal from the dispensers to turn pump on. Requires a signal wire and a neutral. No polarity requirements at the Hook Terminal.

**Pump Motor Terminals:** Labeled GND, BLK, ORG, RED. Connect wires that go to the submersible pump at these terminals. If color codes are not matched at the submersible the motor may run in reverse.

**Input Power Terminals:** Labeled GND, L3, L2, L1. Supplies power for *MagVFC* and the submersible pump.

**Note:** Connect wires accurately. Connecting power wires to any other terminals will cause irreparable damage to the *MagVFC* controller.

**Note:** The *MagVFC* can only be used with FE Petro Pump base models IST, IST VS4, STP VS4, STP VS2, PMA VS4, or PMA VS2. The *MagVFC* is not compatible with competitive makes of variable speed models. The *MagVFC* is not compatible with the IST-VFC for communication in Master/Slave configurations.

**User Interface Panel Is the Front Panel Located Under the MagVFC Cover**

(factory default switch settings shown)

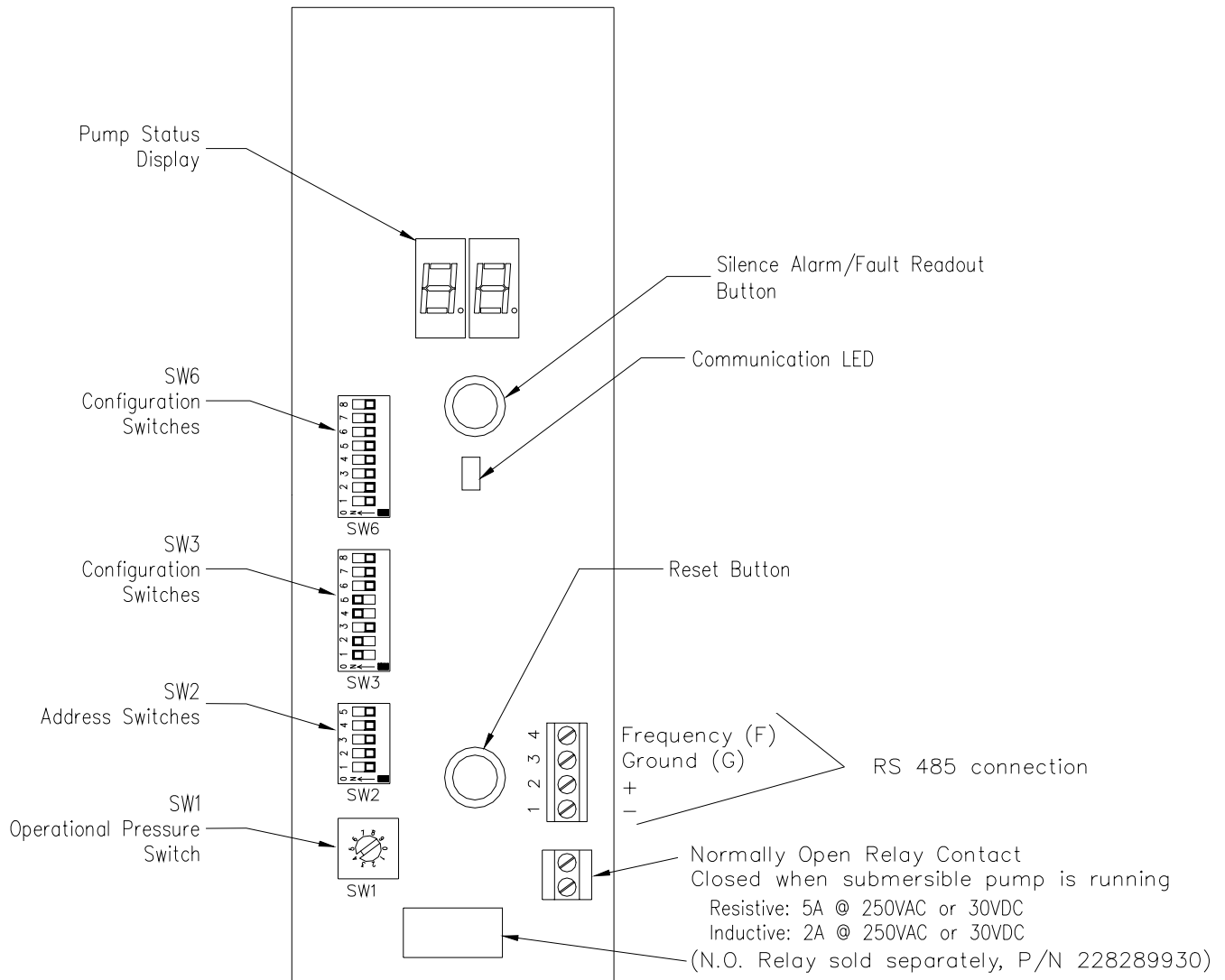

**Figure 2**

**Pump Status Display:** Displays codes that indicate controller or pump status, see the Troubleshooting section for details of codes.

**Silence Alarm/Fault Readout button:** Push and it will turn off audible alarm, Push and hold button and the Pump status display will show the last 3 fault conditions the *MagVFC* encountered.

**Reset Button:** Resets controller of any fault condition

**Communications LED:** Used in Master/Slave type configurations to indicate communication activity

**RS485 connection:** Used in Master/Slave configurations (Frequency connection not used in IST-VFC Mode)

**Relay contact:** Normally open, the relay closes when the pump is running (relay sold separately).

**SW1 Operational Pressure Switch:** Adjusts the submersible pump’s operation pressure

**SW2 Address Switch:** Used in Master/Slave type configurations

**SW3 Configuration switches:** Factory Default settings for Stand alone use in Gasoline. See Options Select Section for other settings.

**SW6 Configuration Switch:** More configuration options, see Options Select Section for specific settings

## **INSTALLATION INSTRUCTIONS**

**Note:** Steps 1 through 3 are also part of the installation instructions for the submersible pump. This is done to ensure all instructions are available to those in need of them during installations. As a result, steps 1-3 may already be complete.

- 1) Connect the electrical conduit with approved fittings to the submersible pump junction box.
- 2) Remove the submersible pump junction box cover, and remove the compression seal by loosening the screw (do not remove the screw). The seal has four holes to accommodate a ground wire and three-phase power from the *MagVFC*.

**Warning**  **Not installing a ground wire increases the risk of potentially lethal electrical shock and equipment failure. All holes of the compression seal (contractors plug) must be filled with wires or a celcon rod to enable it to seal.**

- 3a) Verify that the power is OFF at the supply box. Pull four wires from the spot where the *MagVFC* unit will be mounted into the submersible pump junction box and feed through the compression seal. Slide the compression seal into place and tighten securely. Connect the three wires from the connector assembly to the three phase power wires coming from the *MagVFC*. Connect the fourth wire (ground) from inside to the pump junction box ground lug.

**Note:** All wiring must conform to all applicable guidelines in accordance with all federal, state, and local codes. Failure to comply with all applicable guidelines could result in an unsafe installation. Use the following table for maximum wire length to wire gauge for submersible wiring:

Wire Size	Maximum Run
10 gauge	650 feet
12 gauge	400 feet
14 gauge	250 feet

- 3b) Replace the cover of the pump junction box and securely tighten in place.

**Warning**  **The compression seal is not a replacement for the vapor explosion seals required by the NEC. All materials used between the power supply box and the submersible pump junction box must be gasoline and oil resistant. All wiring used within the *MagVFC* must be rated 90°C, 300V minimum. Failure to comply with these, and all applicable NEC guidelines, could result in an unsafe installation.**

- 4a) Hang the *MagVFC* on a vertical surface and remove the front panel screw and front cover. Install approved electrical conduits only at factory knockouts on the *MagVFC* enclosure.

**Note:** Interference is created by several types of equipment in a station (fluorescent lighting, compressor, etc.), some more than others; this interference can affect the operation of more sensitive equipment (such as tank monitors and electronic line leak detectors) which communicate through data lines. When installing the *MagVFC*, FE Petro recommends that the power wires from the Power Source as well as the power wires to the IST or STP units with VS2 or VS4 suffix (pump) be in their own steel conduit which is not broken or routed through race ways. FE Petro also recommends that all equipment be installed per the manufacturer requirements for best results.

**Note:** The *MagVFC* must be mounted indoors in a non-hazardous location with ambient temperatures between 40° F (4° C) and 95° F (35° C).

**Note:** The *MagVFC* measures 14.25"H x 5.50"W x 9.50"D. To allow room for field adjustments and air clearance, mount the controllers so they have 6" or more of right side (cover side) clearance, and 3" or more left side (heat sink side) clearance. Install with the heat sink fins vertical and the knock-outs down. See Figure 3.

## MagVFC DIMENSIONS AND LAYOUT

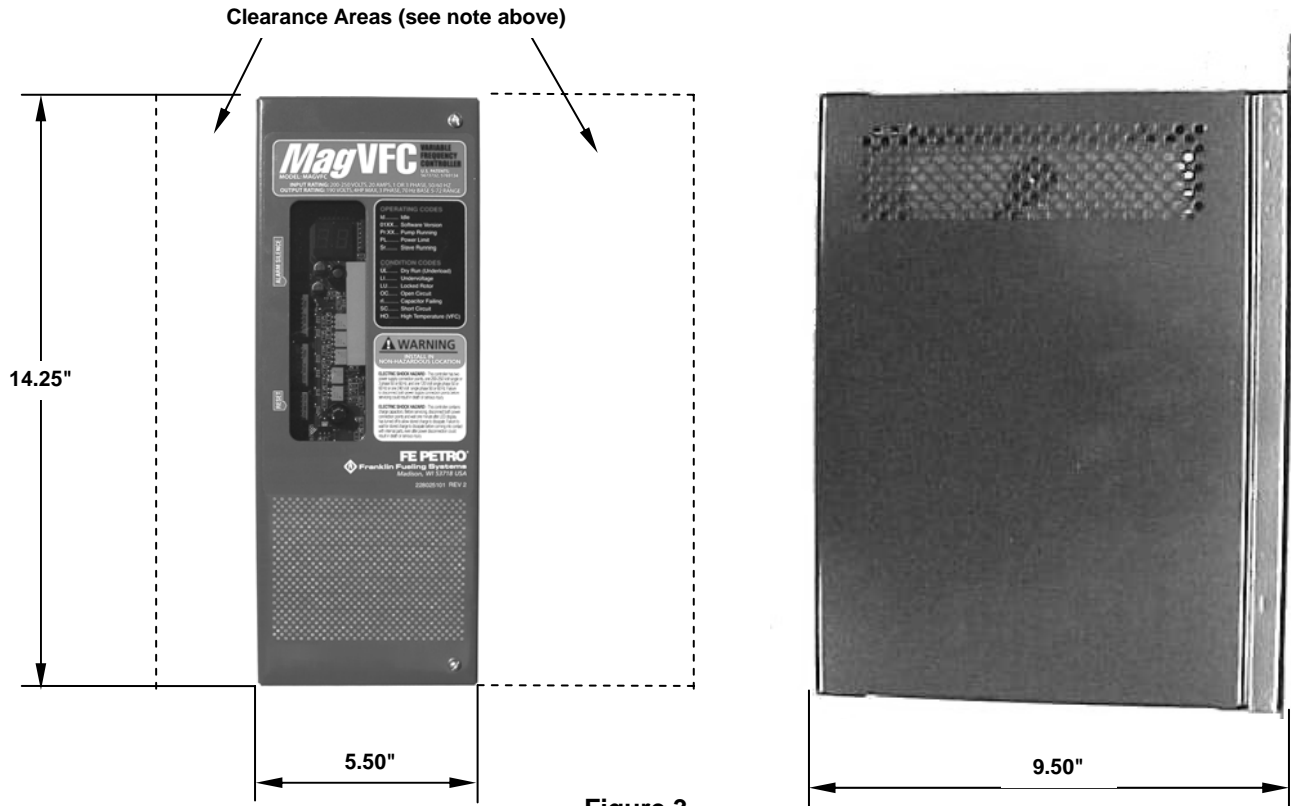

Figure 3

4b) Per Figure 1, connect the three motor control wires from the pump junction box to labeled terminals observing color coding of wires (Black to Black, Orange to Orange, Red to Red). Connect the ground wire from the submersible pump to the ground lug on the *MagVFC* circuit board.

**Warning** ⚠️ To avoid the risk of potentially lethal electrical shock, fire, or explosion, always tag and lock circuit breakers in the off position before opening the *MagVFC*.

**Warning** ⚠️ After disconnecting power to the *MagVFC*, wait one minute after LED display blinks before opening the cover for servicing. Voltage stored in the capacitor bank of the *MagVFC* presents a risk of potentially lethal electrical shock even after power is disconnected.

**Note:** If the motor power wires are not connected with the proper polarity, the motor will run in reverse rotation causing output pressures of approximately 17-29 psi with a PMA VS4 and approximately 10-18 psi with a PMA VS2 connected.

4c) Connect three phase, 200-250V, 50 or 60Hz power supply to terminals to L1, L2 and L3. Reference Figure 1 for wiring details.

**Note:** The *MagVFC* may be connected to single phase power only if used with FE Petro pump motor model PMA VS2 with input power connected to L1 and L2. Reference Figure 1 for wiring details.

**Note:** The PMA VS4 model pump motor requires three-phase input voltage for optimum performance. Operating on single phase input, the performance of the PMA VS4 will be equivalent that of the PMA VS2.

**Warning** ⚠️ Do not connect incoming power to any terminals other than L1, L2, and L3. Connecting input power to any other terminals will cause failure and permanent damage to the *MagVFC*.

4d) Connect dispenser hook signal to the two position terminal block on the *MagVFC* board as detailed in Figure 1.

**Note:** Dispenser hook terminals are capable of accepting voltages from 110 VAC through 240 VAC dispenser signals. The dispenser hook terminals require a signal wire from the dispenser and a Neutral/Return.

4e) Configuration switches are factory set for PMA VS2 in gasoline, mechanical leak detectors, extended run active, and stand-alone operation as detailed below in Figure 4. If you are using a different configuration see the Option Select section of this manual.

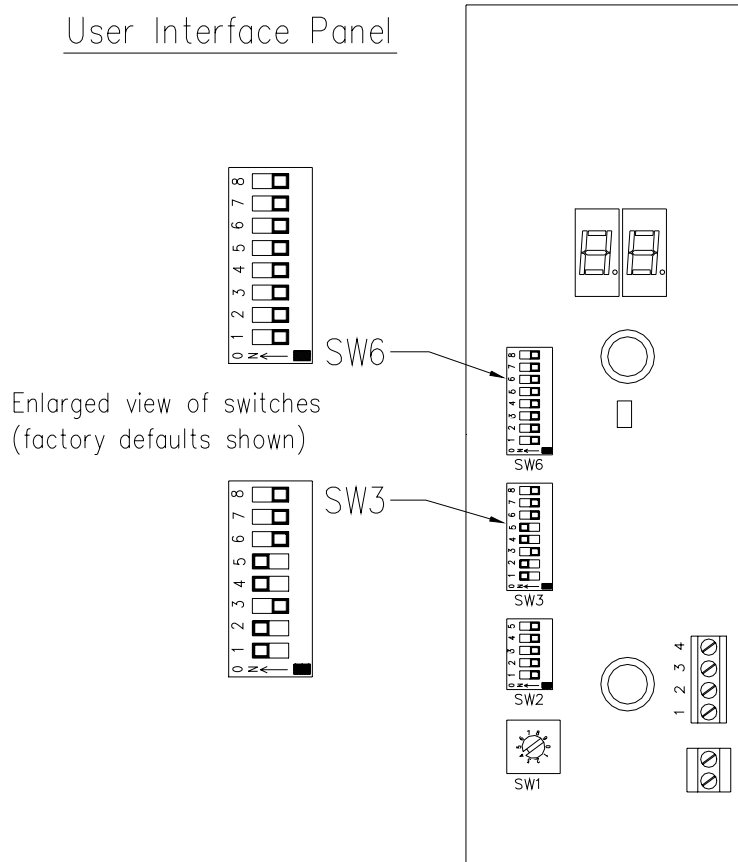

**Figure 4**

## **OPTION SELECT SWITCH SETTINGS**

5a) To make changes to the configuration switches SW3 and SW6 (See *Figure 4*), make sure power supply is locked and tagged out, then remove the two screws from the plastic shield covering the User interface board. Set all DIP switches as desired per the details below.

### **SW3 Pole 1**

**ON** for Mechanical Leak Detectors(**factory setting**)

**OFF** For Some Electronic Line Leak Detection systems. Required setting for Veeder Root PLLD.

### **SW3 Pole 2**

**ON** for Gasoline (**factory setting**)

**OFF** for Diesel product

**Note:** Because gasoline has a different specific gravity than diesel fuel, the correct setting of Pole 2 is important to ensure that the *MagVFC* regulates pressure at the desired level.

### **SW3 Pole 3**

**ON** for Master controller (See Master Slave Control Connections for details)

**OFF** for Stand-alone operation or Slave configuration (**factory setting**)

### **SW3 Poles 4 and 5 (Pipe Compensation)**

See Calibration Section of this Manual for details in setting these switches (default is ON, ON)

### **SW3 Pole 6**

**ON** when using PMAVS4 motor

**OFF** when using PMAVS2 motor (**factory setting**)

**Note:** Incorrect setting can cause the *MagVFC* to give false indications of SC (short circuit) or UL (underload). Set SW3 Pole 6 properly to horsepower of pump connected.

### **SW3 Pole 7**

**ON** for Automatic reset of "Under Load" fault. An empty tank will cause an Under load fault. The *MagVFC* will automatically reset when the condition is corrected.

**OFF** must push Reset button to clear the "Under Load" fault (**factory setting**)

**Note:** Not functional in IST-VFC Compatibility Mode, leave in OFF position.

### **SW3 Pole 8** (for multiple *MagVFC* controllers working together)

See Alternating Circuit Control section for details (default is OFF)

**Note:** Not functional in IST-VFC Compatibility Mode, set with SW2 Pole 5 per Table 1A.

### **SW6 Pole 1**

See Troubleshooting section for details of the Extended Run Alarm

**ON** Will disable the Extended Run Alarm condition

**OFF** The Extended Run Alarm is active (**factory setting**)

**Note:** Not functional in IST-VFC Compatibility Mode, leave in OFF position.

### **SW6 Pole 2** (For Master-Slave and Alternating Circuit configurations ONLY)

See Master-Slave Fault Shutdown Control section for details of this switch (default is OFF)

**Note:** Not functional in IST-VFC Compatibility Mode, set with SW2 Pole 5 per Table 1A.

### **SW6 Pole 3**

**ON** for IST-VFC Compatibility Mode, unit will then ONLY communicate with rev 1.5 software IST-VFCs in Master-Slave configurations (not for use in communicating Master-Slave with other *MagVFC*s)

**OFF** native *MagVFC* Master-Slave communication (**factory setting**)

**Note:** Available in *MagVFC* software versions 1.18 and higher only.

### **SW6 Poles 4 - 8**

These switches are not used. Leave them in the **OFF** position.

**Note:** *MagVFC* may operate in an unpredictable manner if any of the switches, SW6 Poles 3-8, are in the ON position.

6a) Replace the cover of the *MagVFC*.

6b) Insert a 0-100 psi pressure gauge into the 1/4" line test port of the submerged pump (or other pressurized test location in the piping system). Turn power on to the *MagVFC* at the load center, turn on the submerged pump at the dispenser and inspect the line test port for leaks. If there are any leaks, immediately turn off the submerged pump at the dispenser and the load center and repair the leaks.

6c) Begin purging the air from the piping system by activating a dispenser handle and pumping product into an approved container. Verify that while the pump is on but no product is being dispensed, the pressure reading on the gauge is equal to the related pressure from Table 2 in Step 9c, +5/-7 psi.

**Note:** If pressure in the piping system is much lower than selected, it is possible that the polarity of the motor power wires is not correct, causing the motor to run in reverse rotation. Turn off the pump at the power supply, (wait one minute after LED display blanks before opening the cover) and change the connection of any two wires at the pump or at the *MagVFC* motor terminals. Turn the pump back on and read the pressure gauge again. The electrical connection, which gives the higher reading on the pressure gauge, is the correct one.

6d) Complete purging the remaining air from the piping system and dispensers. If using Master-Slave or Master-Slave/Alternating Circuit, continue with next section. If not, go to "*MagVFC* Site Set-Up" section.

### **MASTER-SLAVE CONTROL CONNECTIONS**

**Note:** For Master/Slave and Alternating configurations, the *MagVFC* can only be paired with other *MagVFC*'s. Because of enhanced communication protocols, the *MagVFC* is not capable of communication with the IST-VFC unless SW6 Pole 3 (IST-VFC Compatibility Mode) is switched ON. IST-VFC Compatibility Mode is available in rev 1.18 software or higher *MagVFC*s.

**Warning**  **To avoid the risk of potentially lethal electrical shock, explosion or fire, always tag and lock circuit breakers in the off position before removing the cover of the *MagVFC*.**

**Warning**  **After disconnecting power to the *MagVFC*, wait one minute after LED display blanks before opening the cover for servicing. Voltage stored in the capacitor bank of the *MagVFC* presents a risk of potentially lethal electrical shock even after power is disconnected.**

7a.) When two IST pumps or STP units with VS4 or VS2 suffix are installed to be run in parallel (discharging into the same line) three different modes of operation are possible, as follows:

**Master – Slave:** When a hook voltage is present at the Master it will turn on. When demand for product increases (more nozzles open) the Master will call the Slave controller to turn on. This will maintain the product flow rate in high demand situations. In this configuration, the slave unit(s) will run only when requested to do so by the master unit.

**Alternating Circuit:** The controllers will rotate being the one to turn on as the hook voltage turns on and off. Only one controller is on at a time in this configuration. Not available in IST-VFC Compatibility Mode.

**Master – Slave and Alternating Circuit:** A combination of the above two configurations. The first controller to turn on rotates and when the demand for product increases, additional controllers will be called on to assist.

**RS485 wiring is required for Master/Slave and Alternating configurations.**

See Figure 5 wiring diagram for the RS485 connections.

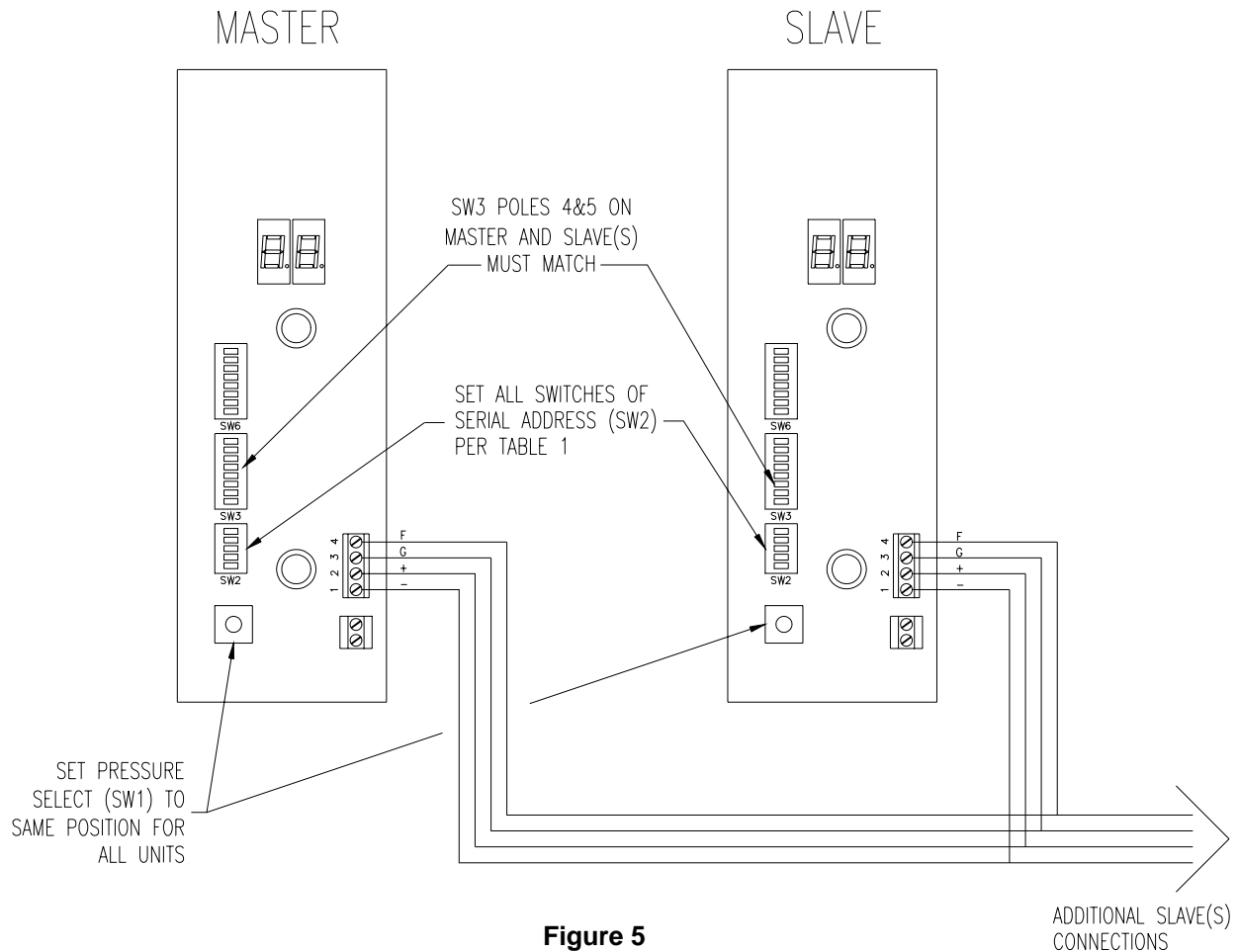

**Figure 5**

**7b) For Master – Slave Configuration (not applicable to IST-VFC Mode)**

Set **Master SW3 Pole 3** to **ON**, **SW3 Pole 8** to **OFF**, and verify that on **SW2** all switches are **OFF**. Set **Slave(s)**, verify that **SW3 Pole 3** and **SW3 Pole 8** are set **OFF** (factory default). Set **SW2** switches of Slave(s) per **Table 1**.

**For Alternating Circuit Configuration (not applicable to IST-VFC Mode)**

Set **Master SW3 Pole 3** to **OFF**, **SW3 Pole 8** to **ON** and **SW2** switches all **OFF**. For **Slave(s)**, **SW3 Pole 3** is set **OFF** (factory default), **SW3 Pole 8** to **OFF** and **SW2** switches per **Table 1**.

**For Master – Slave and Alternating Circuit Configuration (not applicable to IST-VFC Mode)**

Set **Master SW3 pole 3** and **SW3 Pole 8** are **ON** and **SW2** switches all **OFF**. For **Slave(s)**, **SW3 Pole 3** and **SW3 Pole 8** are **OFF** and **SW2** switches per **Table 1**

**Note:** For IST-VFC Compatibility Mode (SW6 Pole 3 ON), set **Master SW3 pole 3 ON**, set **Slaves(s) SW3 pole 3 OFF**, and set **SW2** switches per **Table 1A**.

**Caution**  Line leak detection performance can be affected when using multiple *MagVFCs*. FE Petro does not recommend using the Alternating Circuit feature in conjunction with electronic line leak detection. Some electronic line leak detector manufacturers require that the Master turn on first all of the time. Please refer to the manufacturer's requirements.

- 7c) Another feature of the Master-Slave and/or Alternating Circuit configurations is the ability to have a Slave take command for product delivery if one of the following alarm conditions is present with the Master:
- Underload (Tank Empty)
  - Low Incoming Voltage
  - Locked Rotor in PMA
  - High Temperature in *MagVFC*
  - Over Speed

**SW6 pole 2 (This option only needs to be selected on the Master controller)**

**ON** an alarm condition on any controller will shutdown all controllers. Required setting for VR PLLD.

**OFF** an alarm condition will shutdown only the controller with the alarm. **(factory setting)**

When this option is selected, switch **ON**, the entire system will shutdown if any of the controllers, Master or Slaves, alarms. The system will not run until the alarm is corrected and the reset button is pushed or the Fault Shutdown option switch is turned **OFF** and the reset button is pushed.

- 7d) Wire the RS485, connecting the master *MagVFC* to the slave(s) *MagVFC* as detailed in Figure 5. Wire per NFPA 30A, and NFPA 70. For the signal wires, use at least 22 AWG (300V minimum) 4 conductor shielded cable with a drain and within a common jacket. Cut wires to length so that there is no excess wiring touching circuit board components.

**Note:** When wiring a Master - Slave and/or Alternating Circuit set, connect the signal from the dispenser (hook) to the terminals of the Master *MagVFC* only. The Master controller will energize the Slave(s) when needed without a signal from the dispenser.

- 8) When all connections are complete, reinstall the *MagVFC* covers and activate supply power. Verify that the front panel status indicator is displaying Id (Idle) for both Master and Slave(s)

**Note:** When working with a Master-Slave or Master-Slave/Alternating Circuit configuration, there can be one Master and up to (31) slaves. When connected properly, the yellow Communication LED will flash quickly on the Master unit and flash in sequence through the Slave unit(s). See Figure 2 for location of LED.

<b>Table 1 – Native MagVFC Communication Addressing</b>					
<b>SW2 (see Figure 2 for location of switch)</b>					
<b>Address</b>	<b>Pole 1</b>	<b>Pole 2</b>	<b>Pole 3</b>	<b>Pole 4</b>	<b>Pole 5</b>
Master	Off	Off	Off	Off	Off
Slave - 1	On	Off	Off	Off	Off
Slave - 2	Off	On	Off	Off	Off
Slave - 3	On	On	Off	Off	Off
Slave - 4	Off	Off	On	Off	Off
Slave - 5	On	Off	On	Off	Off
Slave - 6	Off	On	On	Off	Off
Slave - 7	On	On	On	Off	Off
Slave - 8	Off	Off	Off	On	Off
Slave - 9	On	Off	Off	On	Off
Slave - 10	Off	On	Off	On	Off
Slave - 11	On	On	Off	On	Off
Slave - 12	Off	Off	On	On	Off
Slave - 13	On	Off	On	On	Off
Slave - 14	Off	On	On	On	Off
Slave - 15	On	On	On	On	Off
Slave - 16	Off	Off	Off	Off	On
Slave - 17	On	Off	Off	Off	On
Slave - 18	Off	On	Off	Off	On
Slave - 19	On	On	Off	Off	On
Slave - 20	Off	Off	On	Off	On
Slave - 21	On	Off	On	Off	On
Slave - 22	Off	On	On	Off	On
Slave - 23	On	On	On	Off	On
Slave - 24	Off	Off	Off	On	On

<b>Table 1A – Compatibility Mode Addressing &amp; IST-VFC Master-Slave Options</b>						
<b>SW2 (see Figure 2 for location of switch)</b>						
<b>Address</b>	<b>Pole 1</b>	<b>Pole 2</b>	<b>Pole 3</b>	<b>Pole 4</b>	<b>Pole 5 Master-Slave</b>	<b>Pole 5 for Master-Slave Alt. Circuit</b>
Master	Off	Off	Off	Off	On	Off
Slave - 1	Off	Off	Off	On	On	On
Slave - 2	Off	Off	On	Off	On	On
Slave - 3	Off	Off	On	On	On	On
Slave - 4	Off	On	Off	Off	On	On
Slave - 5	Off	On	Off	On	On	On
Slave - 6	Off	On	On	Off	On	On
Slave - 7	Off	On	On	On	On	On
Slave - 8	On	Off	Off	Off	On	On
Slave - 9	On	Off	Off	On	On	On
Slave - 10	On	Off	On	Off	On	On
Slave - 11	On	Off	On	On	On	On
Slave - 12	On	On	Off	Off	On	On
Slave - 13	On	On	Off	On	On	On
Slave - 14	On	On	On	Off	On	On
Slave - 15	On	On	On	On	On	On

## **MagVFC SITE SET UP**

- 9a) Verify rotary switch on *MagVFC* is set to position 4. This will provide approximately 32 psi output from the IST or STP units with VS2 or VS4 suffix, and serves as a good starting point for *MagVFC* calibration.
- 9b) Using a 5 gallon capacity minimum approved container, go to the dispenser closest to the storage tank and perform a Flow Rate Test. If the product being pumped is gasoline, consider following the U.S. EPA Fuel Dispenser Flow Rate Test Procedure (for 10 GPM maximum flow rate standard), where applicable.

**Note:** It is necessary to perform a Flow Rate Test for each product available at the dispenser. This will confirm that all product outputs, including products blended at the dispenser, do not exceed the U.S. EPA 10 GPM maximum, where applicable.

**Note:** Use of “flow restrictors” to control a maximum flow rate of 10 gpm per nozzle (as required by the U.S. EPA) are not required if the variable frequency controller is properly calibrated as defined in “*MagVFC* Site set up Section” section.

- 9c) If output is above or below the desired range (i.e. 8-10 GPM), turn off the pump at the power supply, (wait one minute after LED display blanks before opening the cover) remove the *MagVFC* cover, and adjust the rotary switch (SW1), see Figure 2. This switch will increase or decrease the system operating pressure according to Table 2. An increase in pressure will normally yield an increase in flow rate; a decrease in pressure will reduce flow rate. Replace the *MagVFC* cover and re-apply input voltage. Return to Step 9b above and check GPM with the new settings. Repeat until the output obtained is within the desired range in GPM.

Switch Position	Pressure
0	24 psi
1	26 psi
2	28 psi
3	30 psi
<b>Factory Setting</b>	<b>4</b>
	<b>32 psi</b>
5	34 psi
6	36 psi
7	38 psi
8	40 psi
9	42 psi

Table 2

**Warning**  To avoid the risk of potentially lethal electrical shock, explosion or fire, always tag and lock circuit breakers in the off position before removing the cover of the *MagVFC*.

**Warning**  After disconnecting power to the *MagVFC*, wait one minute after LED display blanks before opening the cover for servicing. Voltage stored in the capacitor bank of the *MagVFC* presents a risk of potentially lethal electrical shock even after power is disconnected.

**Note:** Additives in gasoline can change the specific gravity of gasoline, which may cause the pressures stated in the above Table 2 to vary.

- 9d) Optimize Pipe Compensation settings by doing another Flow Rate Test; this time with two other nozzles from the same product open at the same time as your test nozzle. If the flow rate at the test nozzle falls from the desired range with three nozzles open, increase SW3 pole 4 and pole 5 to the next highest compensation setting (0 to 1 or 1 to 2 for example). If output exceeds the desired range, decrease to the next lowest compensation setting (2 to 1 or 1 to 0 for example). Repeat this step until compensation setting is optimal for your installation.

## SW3 pole 4 and pole 5

	Compensation	SW 3 Pole 4	SW3 Pole 5	Piping Configuration
<b>Factory Setting</b>	0	ON	ON	least restrictive
	1	ON	OFF	...
	2	OFF	ON	...
	3	OFF	OFF	most restrictive

**Table 3**

**Note:** An example of a small restriction piping system would be 2" fiberglass running less than 150'. An example of a restrictive piping system would be 1 1/2" convoluted flexible piping greater than 75' in length.

**Note:** When working with a Master-Slave or Master-Slave/Alternating Circuit configuration, the piping compensation must be identical in all controllers.

## Display Definitions

The *MagVFC* is equipped with a display that indicates several operating parameters of the *MagVFC* as well as indicates an error code when a fault is detected. When the *MagVFC* is in an error condition, the alarm code will be displayed. The alarm code definitions and proposed troubleshooting methods are in the **Troubleshooting** section of this manual.

Code	Definition	Description	Displayed
<b>Id</b>	Idle	No hook signal present, PMA is not running, and no fault codes present	When Pump is idle (i.e. no hook signal is present)
<b>xx : yy</b>	Software revision	Software version of <i>MagVFC</i> where numeric value <b>xx</b> displays and then value <b>yy</b> to form the revision <b>xx.yy</b>  Note: If the display stops on <b>yy</b> , there may be an issue of low incoming voltage or loose input power connections.	Immediately after the <i>MagVFC</i> has been reset or turned ON
<b>Pr : NN</b>	Pressure regulate	<b>Pr</b> is the pressure setting of <b>NN</b> psi that the <i>MagVFC</i> is set to maintain. <b>Pr</b> and the numeric value <b>NN</b> of the set pressure will flash alternately on the display when running	<i>MagVFC</i> is running and operating within pressure regulate setting
<b>PL</b>	Power Limit	Displayed when <i>MagVFC</i> is operating at its power limit	<i>MagVFC</i> is running and operating beyond pressure regulate setting
<b>Sr</b>	Slave running	Displayed when a slave in a Master-Slave configuration is running	On slave pump only when operating

**Table 4**

## **TROUBLESHOOTING GUIDE**

To aid field service personnel, the *MagVFC* is able to diagnose abnormal operating conditions, and communicate them via the display on the front panel. The display indicates the operating status of the controller and, if an alarm is present, displays the alarm condition. The following tables show the alarm codes, as well as provides suggested troubleshooting steps.

The *MagVFC* is also equipped with a **Reset Button** to clear faults and a **Silence Audible Alarm Button** that turns off the audible alarm when depressed. Depressing the silence audible alarm button does not clear the fault; it only silences the alarm. **Pushing and holding the Silence Button will put the Pump Status Display in fault readout mode, showing the last 3 fault conditions encountered by the *MagVFC*, ie. F0 is followed by the code of the last fault encountered, F1 is second to last fault encountered, F2 is third to last fault encountered (sequence through the codes by briefly pushing the Silence Button after each code is displayed until the Pump Status Display returns to normal status).**

<b>Code</b>	<b>Condition</b>	<b>Potential Causes</b>	<b>Proposed Action</b>
<b>UL</b>	Under-load, Tank Empty  Incorrect horsepower setting	Low fuel level in the storage tank/Obstruction on intake of PMA  SW3 Pole 6 set incorrectly for pump connected	<ol style="list-style-type: none"> <li>1. Push reset button on the <i>MagVFC</i>.</li> <li>2. If condition is corrected, check for proper operation of system; if operating correctly do not continue to next step. If condition is still present continue to next step.</li> <li>3. Check SW3 Pole 6 setting and verify that it matches the horsepower of the pump connected. Connecting VS2 motor with a SW3 Pole 6 ON (4hp) setting, may cause this false indication when operating in SW1 positions 0 - 6.</li> <li>4. Check fuel level in storage tank; if product level is low schedule fuel delivery, when delivery is complete and fuel level is above PMA end bell, push reset button on <i>MagVFC</i> Check for correct system operation.</li> <li>5. If condition is not corrected, it is possible that there is an obstruction (rag or absorbent pad) on the inlet of the PMA.</li> </ol>
<b>LI</b>	Low Incoming Voltage	Voltage fluctuations or low input voltage.	<ol style="list-style-type: none"> <li>1. Push reset button on the <i>MagVFC</i>.</li> <li>2. If condition is corrected, check for proper operation of system; if operating correctly do not continue to next step. If condition is still present continue to next step.</li> <li>3. Use AC voltmeter to verify incoming voltage is within the 200-250VAC acceptable range. If voltage is not within this range, contact an electrician to correct problem.</li> </ol>
<b>LU</b>	Locked Rotor fault at PMA startup	Foreign material in PMA or defective PMA.	<ol style="list-style-type: none"> <li>1. Push reset button on the <i>MagVFC</i>.</li> <li>2. If condition is corrected, check for proper operation of system; if operating correctly do not continue to next step. If condition is still present continue to next step.</li> </ol> <p><b>PMA Inspection</b></p> <ol style="list-style-type: none"> <li>3. Disconnect input voltage at load center, lock and tag circuit breakers.</li> <li>4. Remove two 9/16" bolts from extractable portion of the manifold. Disengage the 3/4" securing bolt of the electrical connector and swing out of the way.</li> <li>5. Pull extractable part of the pump. <b>Note:</b> Pump Motor Assembly shell can be damaged by blows from hard surfaces; use care in removing it.</li> <li>6. Remove black end cap from PMA and attempt to spin rotor with a 3/16" Allen wrench to determine if there is any binding. If binding or physical damage, continue with next step. If no binding or physical damage to the PMA, and it is a new installation, reinstall extractable.</li> </ol> <p style="text-align: center;">(continued next page)</p>

Code	Condition	Potential Causes	Proposed Action
<b>LU (cont.)</b>	Locked Rotor fault at PMA startup (con't)  (see note below)	Foreign material in PMA or defective PMA (con't).	<p>7. Turn on the power to the <i>MagVFC</i> unit and verify correct system operation. If condition is corrected, do not continue to the next step. If condition is still present, remove the extractable (repeat Steps 3, 4, and 5) and continue to the next step. <b>Note:</b> PMA can have a locked rotor during startups if it has been exposed to a corrosive environment, such as a tank ballasted in water.</p> <p>8. Remove four 5/16" cap screws that connect the PMA with ¼" Allen wrench and remove the PMA from the motor discharge head. <b>Note:</b> Prior to mounting a new PMA, check lead assembly (wires inside the extractable portion to PMA) for shorted wires which may have caused the condition.</p> <p>9. Replace with a new <b>variable speed (PMAMVS4 or PMAVS2)</b> pump motor. <b>Note:</b> Pump motor shell can be damaged by blows from hard surfaces; use care in replacing.</p> <p>10. Re-install extractable and secure by following reverse order of disassembly.</p> <p>11. Turn on power to the <i>MagVFC</i> unit and verify correct system operation.</p>

**Note:** In rare installations where motor wiring runs are extremely long and/or of a small wire diameter, a false LU (locked up) may be displayed on the *MagVFC*. See the table of recommended maximum wire length to wire gauge for submersible wiring in the beginning of this manual.

Code	Condition	Potential Causes	Proposed Action
<b>Er</b>	Extended Run	Continuous hook signal applied for greater than 60 minutes without change in pumping product flow rate	<p>1. Disconnect power at load center. Lock and tag out circuit breaker.</p> <p>2. Check voltage across hook terminals with all dispenser handles off. There should be no voltage applied. If voltage is present, contact an electrician to correct the problem. After the problem has been corrected, turn on input power and verify system is operating correctly.</p>
<b>SU</b>	Upper rail short	Short Circuit condition in field wiring or component failure internal to the <i>MagVFC</i>	<p>1. Press reset button on <i>MagVFC</i></p> <p>2. Check for proper operation.</p> <p>3. If fault re-occurs turn off power to <i>MagVFC</i>, lock out and tag circuit breaker. Disconnect the wires to the STP at the controller terminals marked Black, Orange and Red.</p> <p>4. Use wire nuts and cap each wire off to prevent any possible shorts in the controller. Turn power on to the <i>MagVFC</i> and observe the display. If the controller indicates an OC (open circuit) condition follow the troubleshooting steps for a short circuit</p> <p>5. If controller display indicates the SU (upper rail short) condition then replace the <i>MagVFC</i>.</p>
<b>rl</b>	Capacitor bank	Bad <i>MagVFC</i> capacitor bank	<p>1. Push reset button on the <i>MagVFC</i>.</p> <p>2. If fault condition still exists, replace <i>MagVFC</i> unit.</p> <p>3. If fault is cleared observe the <i>MagVFC</i> in normal operation for approximately 10 minutes to see if it functions normally. If error resurfaces, replace <i>MagVFC</i>.</p>

Code	Condition	Potential Causes	Proposed Action
<b>OS</b>	Over Speed	<i>MagVFC</i> operating outside of range of operating frequency	<ol style="list-style-type: none"> <li>1. Press reset button to reset <i>MagVFC</i></li> <li>2. Check for proper operation. If condition is still present, power down unit completely and wait 30 seconds.</li> <li>3. Turn on power and check for proper operation.</li> <li>4. If fault re-occurs, replace <i>MagVFC</i></li> </ol>
<b>OC</b>	Open circuit (from <i>MagVFC</i> to motor)  (see note below)	Connection broken from <i>MagVFC</i> to PMA	<ol style="list-style-type: none"> <li>1. Push reset button on the <i>MagVFC</i>.</li> <li>2. If condition is corrected, check for proper operation of system; if operating correctly do not continue to next step. If condition is still present continue to next step.</li> </ol> <p><b><i>MagVFC</i>/PMA Connections</b></p> <ol style="list-style-type: none"> <li>3. Disconnect power at load center, lock and tag circuit breakers.</li> <li>4. Remove the three motor control outputs from the <i>MagVFC</i> unit.</li> <li>5. Using an ohmmeter on 200 setting, place leads between these three wires from the pump motor, this is the first step in determining where the open circuit has occurred. Correct reading between any two of the three wires should be 1.2 +/-1 ohms for a VS4 and 2.5 +/-1 ohms for a VS2.</li> <li>6. Continue conductivity tests on the remaining combinations of wires (3 total). Note results, e.g. Black to red = 2 ohms. Readings between any of the three motor control wires and ground should be an open circuit. If readings in this step are incorrect go to Step 7; if readings are correct, contact FE Petro Technical Support for assistance.</li> <li>7. Go to the submerged turbine and remove the cover at the top of the extractable manifold; remove the three wire nuts.</li> <li>8. Place an ohmmeter between the three wires leading to the pump motor as above. If readings are incorrect go to PMA replacement in 3 flashes section; if readings are correct, there is problem with the wiring between the <i>MagVFC</i> and this point.</li> <li>9. Remove the junction box cover and do conductivity test on wires from junction box to extractable discharge head. If wires are not conducting replace the male and female connectors of the submerged turbine. If there is no problem with these connections the wires from the <i>MagVFC</i> to the submerged turbine are suspect. Contact an electrician to correct the problem.</li> <li>10. After the problem has been corrected turn on power to <i>MagVFC</i> and verify system is operating correctly.</li> </ol>

**Note:** In rare installations where motor wiring runs are extremely long and/or of a small wire diameter, a false OC (open circuit) may be displayed on the *MagVFC*. See the table of recommended maximum wire length to wire gauge for submersible wiring in the beginning of this manual.

Code	Condition	Potential Causes	Proposed Action
<b>SC</b>	<p>Short circuit</p> <p>Incorrect horsepower setting</p>	<p>Short in connections from <i>MagVFC</i> to PMA</p> <p>SW3 Pole 6 set incorrectly for pump connected</p>	<ol style="list-style-type: none"> <li>1. Push reset button on the <i>MagVFC</i>.</li> <li>2. If condition is corrected, check for proper operation of system; if operating correctly do not continue to next step. If fault is still present continue to next step.</li> <li>3. Check SW3 Pole 6 setting and verify that it matches the horsepower of the pump connected. Connecting VS4 motor with a SW3 Pole 6 OFF (2hp) setting, may cause this false indication.</li> </ol> <p><b><i>MagVFC/PMA Connections</i></b></p> <ol style="list-style-type: none"> <li>4. Disconnect power at load center, lock and tag circuit breakers.</li> <li>5. Remove the three motor control outputs from the <i>MagVFC</i> unit.</li> <li>6. Using an ohmmeter on 200 setting, place leads across any two of the three wires from the pump motor. Correct reading between any two of the three wires should be 1.2 +/-1 ohms for a VS4 and 2.5 +/-1 ohms for a VS2.</li> <li>7. Continue conductivity tests on the remaining combinations (3 total). Readings between any of the three motor control wires and ground should be greater than 80k ohms. If readings are incorrect proceed to Step 8. If readings are correct, the possibility of a short circuit in the connections from the <i>MagVFC</i> to PMA still exists. Contact FE Petro Technical Support for additional troubleshooting assistance.</li> <li>8. Go to the submerged turbine and remove the cover at the top of the extractable; remove the three wire nuts.</li> <li>9. Place an ohmmeter between the three wires leading to the pump motor as above. If wires are shorted go to PMA replacement in 3 flashes section; if readings are correct there is problem with the wiring between the <i>MagVFC</i> and this point.</li> <li>10. Remove the junction box cover and do conductivity test on wires from junction box to extractable discharge head. If wires are shorted to ground or each other, replace the male and female connectors of the submerged turbine. If there is no problem with these connections the wires from the <i>MagVFC</i> to the submerged turbine are suspect. Contact an electrician to diagnose and correct the problem.</li> <li>11. After the problem has been corrected turn on power to the <i>MagVFC</i> and verify system is operating correctly.</li> </ol>
<b>HO</b>	High temperature	Excessive operating temperature in <i>MagVFC</i>	<ol style="list-style-type: none"> <li>1. Verify that fan is running properly. If not, replace Fan.</li> <li>2. Check excessive heat in area where control box is mounted.</li> <li>3. Verify all louvers for ventilation are free from obstruction. Remove obstruction and cycle power to reset <i>MagVFC</i>.</li> <li>4. If neither of these conditions exist, replace <i>MagVFC</i> unit.</li> </ol>
<b>Lr</b>	Locked rotor fault with PMA running	Foreign material in PMA or defective PMA	<ol style="list-style-type: none"> <li>1. Push reset button on the <i>MagVFC</i>.</li> <li>2. If condition is corrected, check for proper operation of system; if operating correctly do not continue to next step. If condition is still present continue to next step.</li> </ol> <p><b>PMA Inspection</b></p> <ol style="list-style-type: none"> <li>3. Disconnect input voltage at load center, lock and tag circuit breakers.</li> <li>4. Remove two 9/16" bolts from extractable portion of the manifold. Disengage the 3/4" securing bolt of the electrical connector and swing out of the way.</li> </ol>

Code	Condition	Potential Causes	Proposed Action
Lr	Locked rotor fault with PMA running (con't)  (see note below)	Foreign material in PMA or defective PMA (con't)	(continued next page) 5. Pull extractable part of the pump. <b>Note:</b> Pump Motor Assembly shell can be damaged by blows from hard surfaces; use care in removing it. 6. Remove black end cap from PMA and attempt to spin rotor with a 3/16" Allen wrench to determine if there is any binding. If binding or physical damage, continue with next step. If no binding or physical damage to the PMA, and it is a new installation, reinstall extractable. 7. Turn on the power to the <i>MagVFC</i> unit and verify correct system operation. If condition is corrected, do not continue to the next step. If condition is still present, remove the extractable (repeat Steps 3, 4, and 5) and continue to the next step. <b>Note:</b> PMA can have a locked rotor during startups if it has been exposed to a corrosive environment, such as a tank ballasted in water. 8. Remove four 5/16" cap screws that connect the PMA with 1/4" Allen wrench and remove the PMA from the motor discharge head. <b>Note:</b> Prior to mounting a new PMA, check lead assembly (wires inside the extractable portion to PMA) for shorted wires which may have caused the condition. 9. Replace with a new <b>variable speed (VS4 or VS2)</b> pump motor. <b>Note:</b> Pump motor shell can be damaged by blows from hard surfaces; use care in replacing. 10. Re-install extractable and secure by following reverse order of disassembly. 11. Turn on power to the <i>MagVFC</i> unit and verify correct system operation.

**Note:** In rare installations, a partial short can result from a nick in one of the pump power wires coupled with water in the electrical conduit from the *MagVFC* to the pump. This condition is not a direct short, so the *MagVFC* does not flash short circuit (SC). Instead, the *MagVFC* will see this condition as abnormally high power consumption, and flash locked rotor (LR).

<b>MagVFC Replacement Parts</b>	
Description	Part Number
Fan Assembly	223919930
User Interface Board	225040930
Normally Open Relay	228289930
Window Lens	402623930

WIRE DIAGRAM FOR MAGVFC WITH PMAVS2  
STAND ALONE

NOTE: SEE PRODUCT INSTALLATION INSTRUCTIONS FOR FURTHER DETAILS. WIRING MUST CONFORM TO ALL FEDERAL, STATE, AND LOCAL CODES. CONTROL PANELS ARE FOR NON-HAZARDOUS, INDOOR USE ONLY.

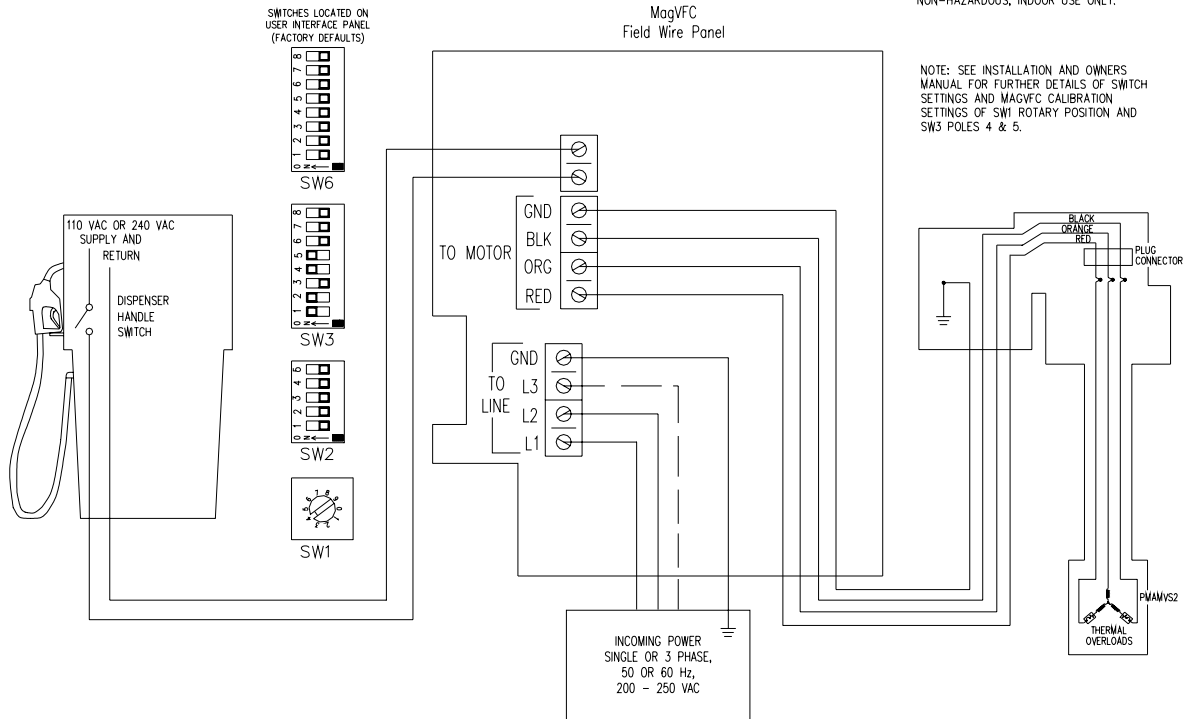

Figure 6 - Stand Alone configuration of MagVFC with 2 horsepower variable speed (VS2)

WIRE DIAGRAM FOR MAGVFC WITH PMAVS4  
STAND ALONE

NOTE: SEE PRODUCT INSTALLATION INSTRUCTIONS FOR FURTHER DETAILS. WIRING MUST CONFORM TO ALL FEDERAL, STATE, AND LOCAL CODES. CONTROL PANELS ARE FOR NON-HAZARDOUS, INDOOR USE ONLY.

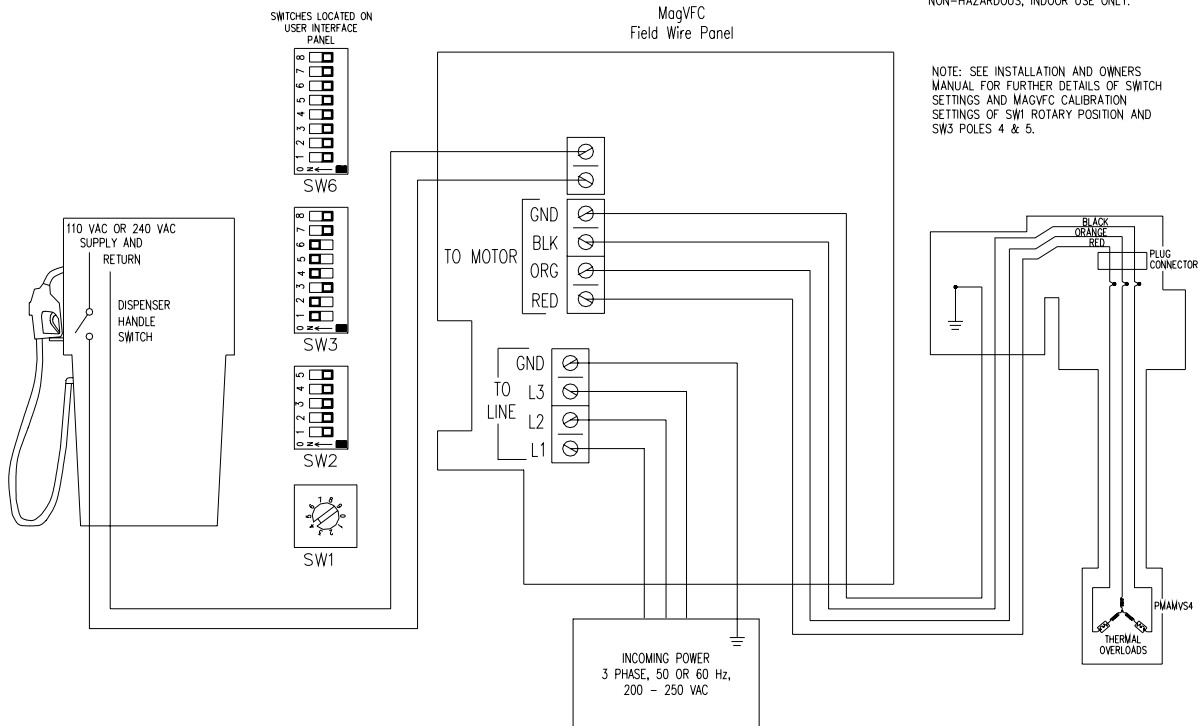
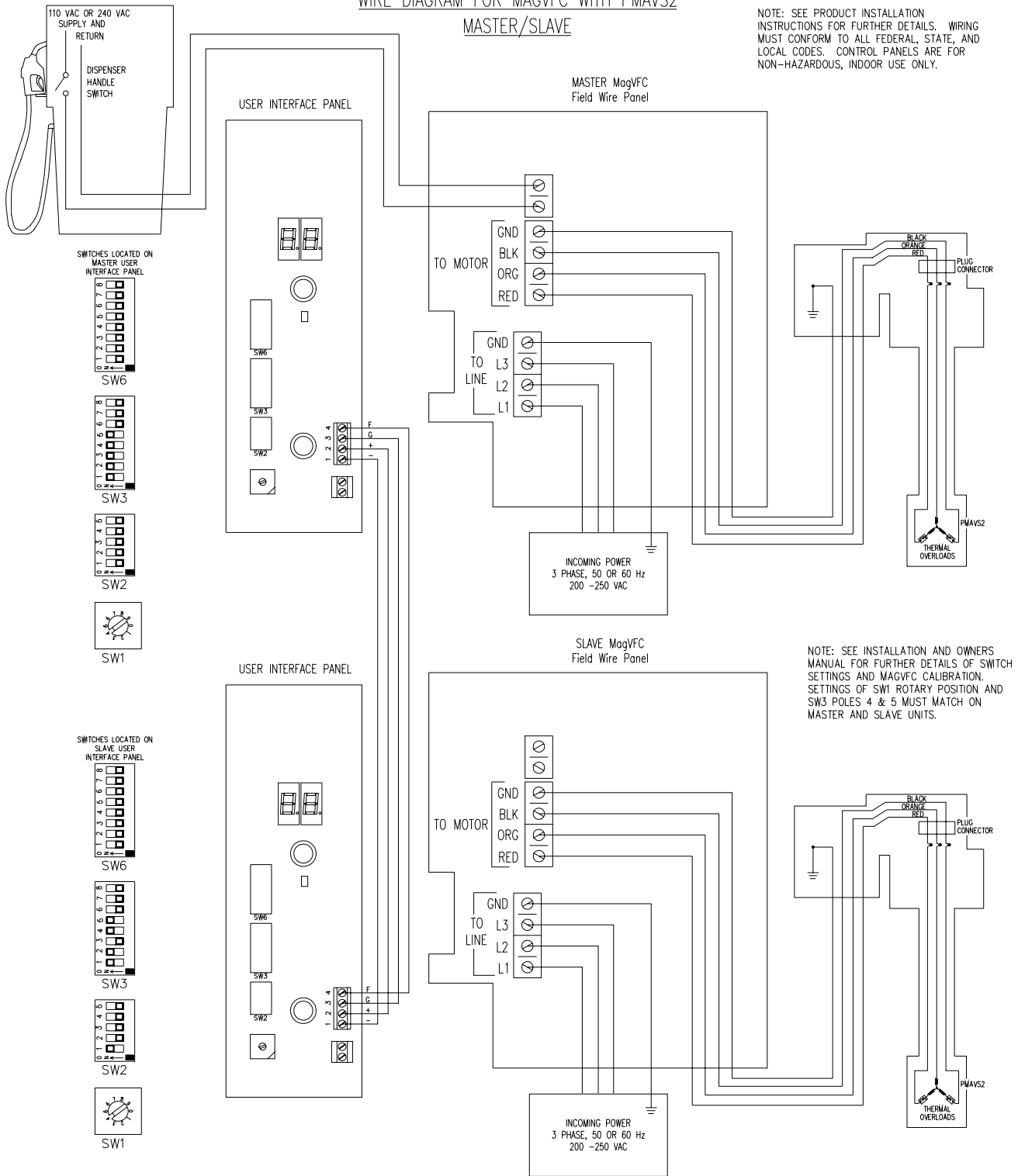

Figure 7 - Stand Alone configuration of MagVFC with 4 horsepower variable speed (VS4)

WIRE DIAGRAM FOR MAGVFC WITH PMAVS2  
MASTER/SLAVE

NOTE: SEE PRODUCT INSTALLATION INSTRUCTIONS FOR FURTHER DETAILS. WIRING MUST CONFORM TO ALL FEDERAL, STATE, AND LOCAL CODES. CONTROL PANELS ARE FOR NON-HAZARDOUS, INDOOR USE ONLY.



**Figure 8 - Master/Slave configuration of MagVFC with 2 horsepower variable speed (VS2) (for connecting with VS4 pumps, turn SW3 Pole 6 ON for controller connected)**

WIRE DIAGRAM FOR MAGVFC WITH PMAVS2  
ALTERNATING CIRCUIT

NOTE: SEE PRODUCT INSTALLATION INSTRUCTIONS FOR FURTHER DETAILS. WIRING MUST CONFORM TO ALL FEDERAL, STATE, AND LOCAL CODES. CONTROL PANELS ARE FOR NON-HAZARDOUS, INDOOR USE ONLY.

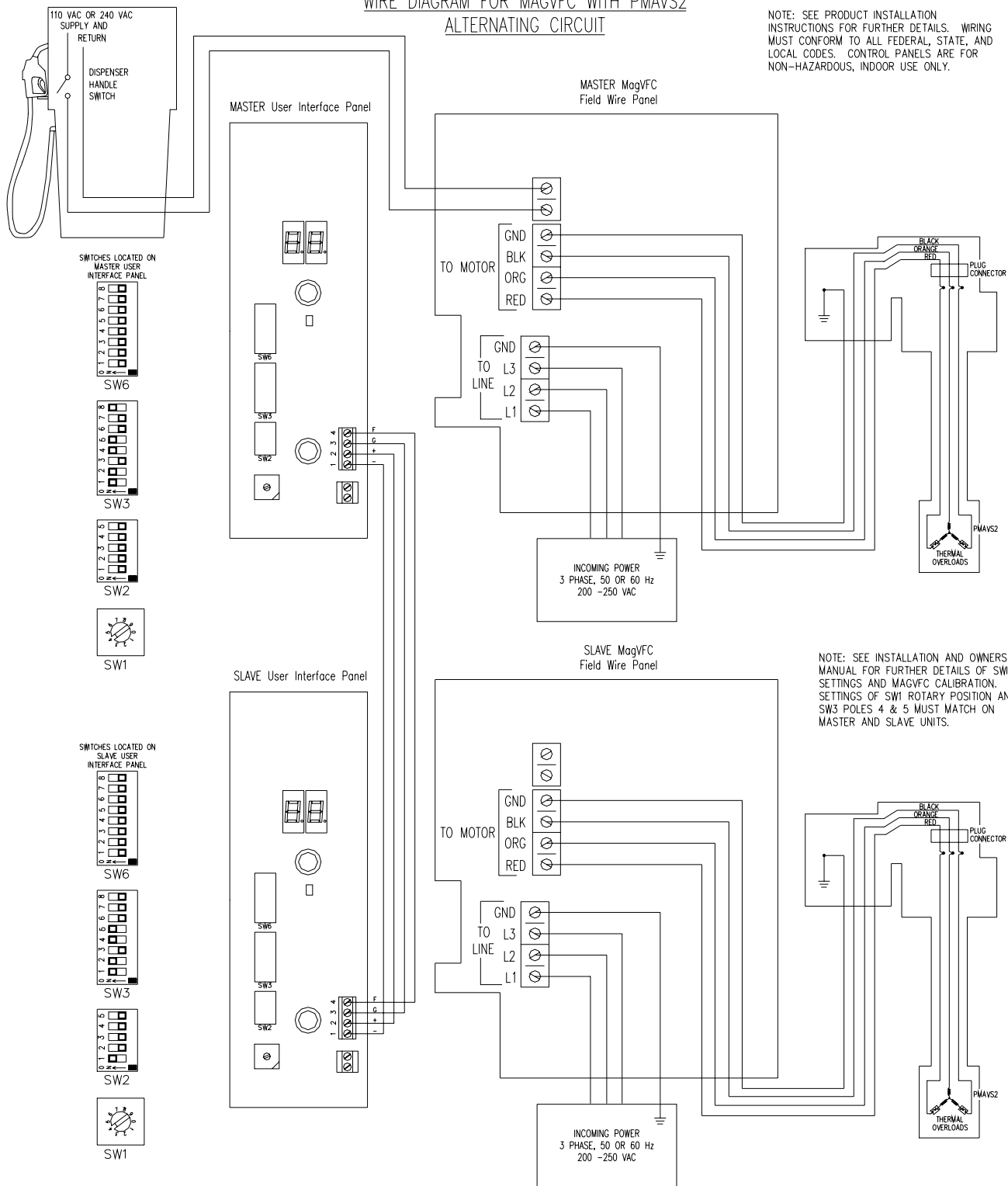

**Figure 9 - Alternating Circuit configuration of MagVFC with 2 horsepower variable speed (VS2) (for connecting with VS4 pumps, turn SW3 Pole 6 ON for controller connected)**



## IST-VFC Compatibility Mode Diagrams

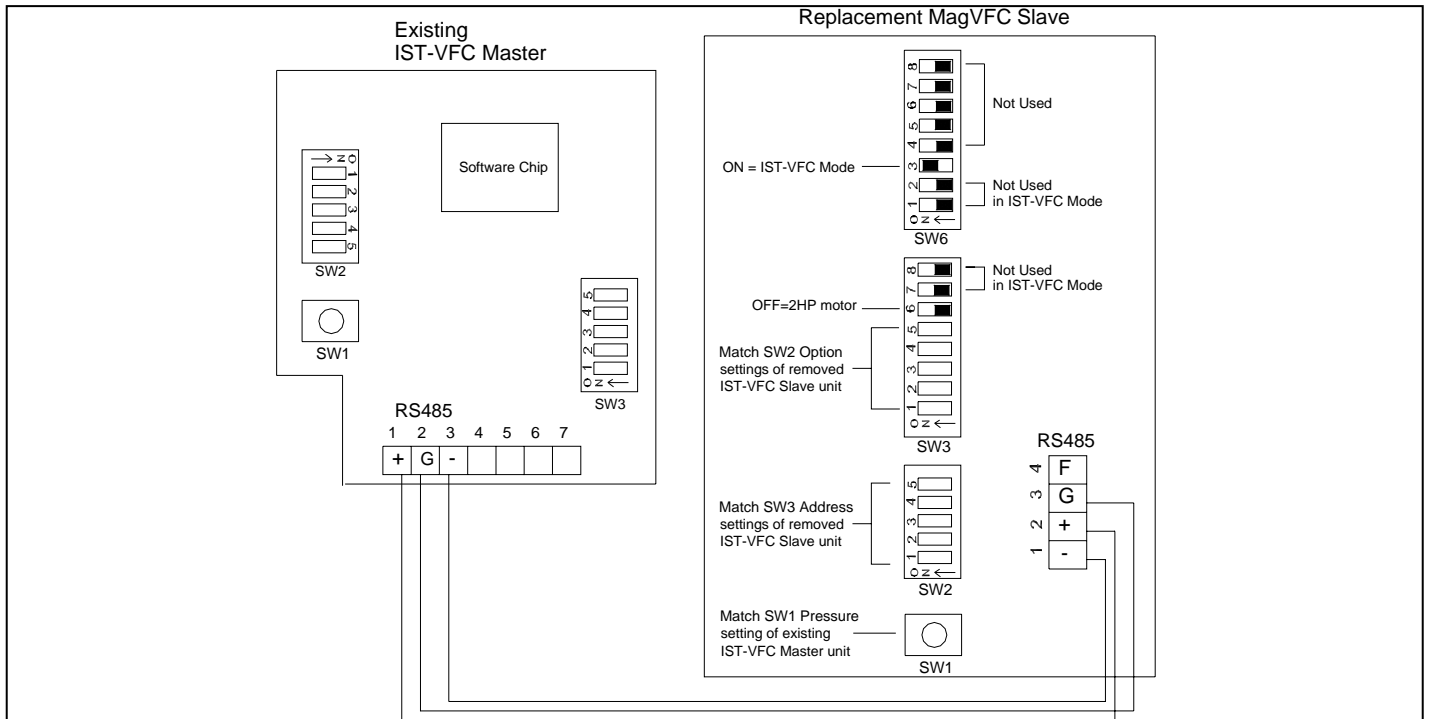

**Figure 1 – Replacement MagVFC as Slave in IST-VFC Compatibility Mode**

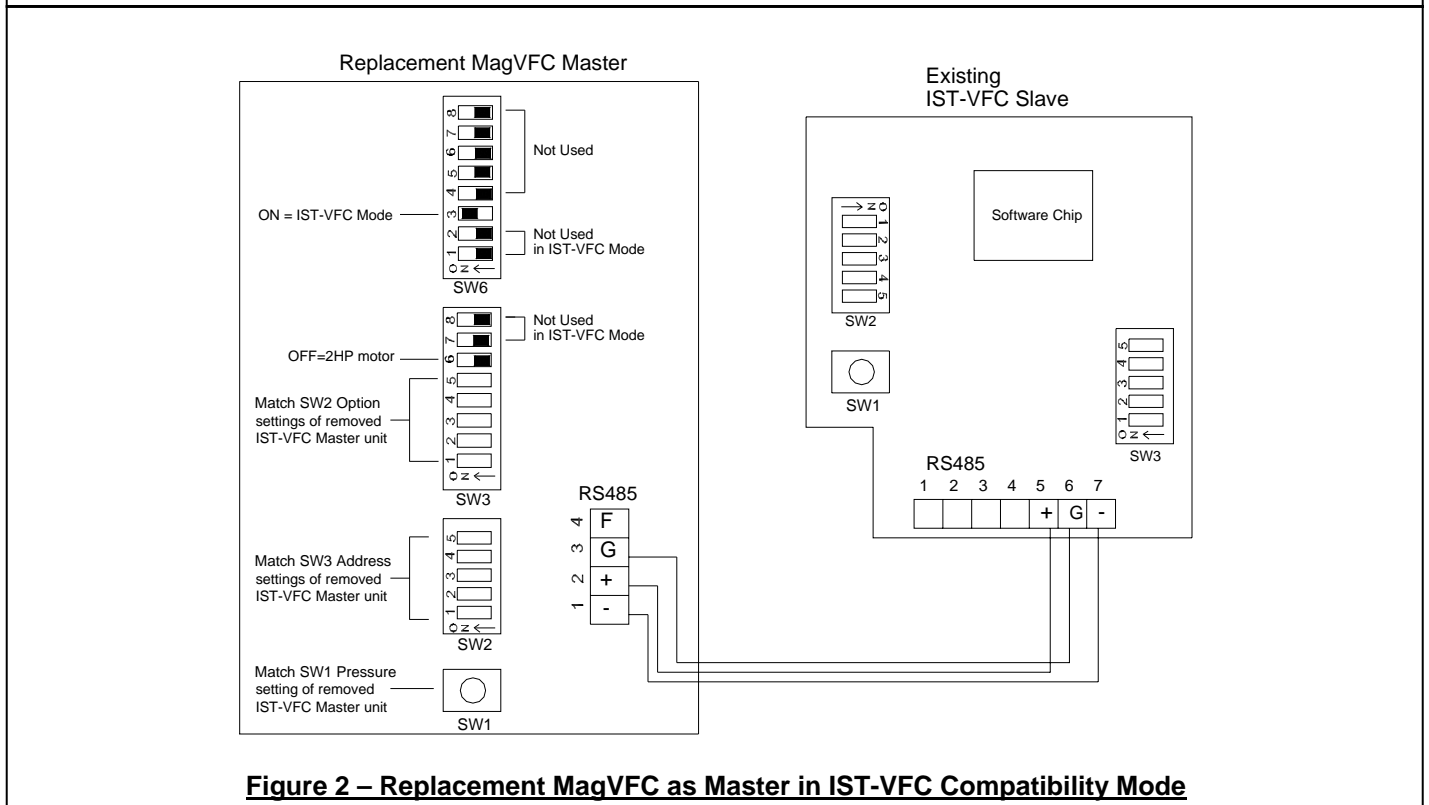

**Figure 2 – Replacement MagVFC as Master in IST-VFC Compatibility Mode**



3760 Marsh Road • Madison, WI 53718 U.S.A.  
 Tel: +1 608 838 8786 • Fax: +1 608 838 6433 • [www.franklinfueling.com](http://www.franklinfueling.com)  
 Tel: USA & Canada 1 800 225 9787 • Tel: Mexico 001 800 738 7610