











STP-MLD-HC & -HCD

Installation and Owner's Manual

Important Safety Messages

FE Petro equipment is designed to be installed in association with volatile hydrocarbon liquids such as gasoline and diesel fuel. Installing or working on this equipment means working in an environment in which these highly flammable liquids may be present. **Working in such a hazardous environment presents a risk of severe injury or death if these instructions and standard industry practices are not followed. Read and follow all instructions thoroughly before installing or working on this, or any other related equipment.**

As you read this guide, please be aware of the following symbols and their meanings:

- Warning**  This symbol identifies a warning. A warning sign will appear in the text of this document when a potentially hazardous situation may arise if the instructions that follow are not adhered to closely. A potentially hazardous situation may involve the possibility of severe bodily harm or even death.
- Caution**  This is a caution symbol. A caution sign will appear in the text of this document when a potentially hazardous environmental situation may arise if the instructions that follow are not adhered to closely. A potentially hazardous environmental situation may involve the leakage of fuel from equipment that could severely harm the environment.
-
- Warning**  **Follow all applicable codes governing the installation and servicing of this product and the entire system. Always lock out and tag electrical circuit breakers while installing or servicing this equipment and related equipment. A potentially lethal electrical shock hazard and the possibility of an explosion or fire from a spark can result if the electrical circuit breakers are accidentally turned on during installation or servicing. Do not smoke while working on or near this equipment, and use only non-sparking tools.**
- Warning**  **Before entering a containment sump, check for the presence of hydrocarbon vapors. If these vapors are inhaled they could cause dizziness or unconsciousness, and, if ignited, hydrocarbon vapors could explode causing serious injury or death. Electronic and electrical petroleum monitoring equipment is often housed in containment sumps designed to trap hazardous liquid spills and prevent contamination of the environment, and, as a consequence, containment sumps can trap dangerous amounts of hydrocarbon vapors. If these vapor levels reach unsafe amounts, ventilate the sump with fresh air. While working in the sump, periodically check the atmosphere in the sump, if vapors reach unsafe levels, exit the sump and ventilate it before continuing work. Always have a second person standing by for assistance when working in, or around, a containment sump.**
- Warning**  **Follow all federal, state, and local laws governing the installation of this product and its associated systems. When no other regulations apply, follow NFPA codes 30, 30A, and 70 from the National Fire Protection Association. Failure to follow these codes could result in severe injury, death, serious property damage, and/or environmental contamination.**
- Warning**  **Always secure the work area from moving vehicles. The equipment in this manual is usually mounted underground, so reduced visibility puts service personnel working on this equipment in danger from moving vehicles entering the work area. To help eliminate these unsafe conditions, secure the area by using a service truck to block access to the work environment, or by using any other reasonable means available to ensure the safety of service personnel.**
- Warning**  **Thermal expansion can cause pressure to build up in the product lines. FE Petro STP/ISTs have a built-in relief valve to release this excess line pressure back to the tank. Do not use an additional check valve unless it has the capability to relieve excess pressure back to the tank, as this could result in a buildup of abnormal pressure in the lines, causing a pipe or joint in the supply line piping to burst, and release of fuel into the environment.**
- Warning**  **This leak detector is designed for use in certain applications and in compliance with industry standards and practices. Use in different applications or failure to follow industry standards and practices may cause the product to malfunction or fail. The following product information and use instructions are particularly important.**
- Warning**  **Do not attempt to disassemble the leak detector. Some parts are under strong spring tension and could cause severe injury if not handled properly.**

Installer: This instruction booklet **MUST** be left with the owner of the service station at which the equipment is being installed.

Station Owner: Retain these instructions for future use and provide them to persons servicing or removing this equipment.

STP-MLD-HC Introduction

STP-MLD-HC & -HCD units are piston-operated mechanical leak detectors intended for installation only in a petroleum pumping system operating with 20 to 50 PSI pump pressure with less than 12 feet of static fluid head. They automatically indicate pipeline faults which leak 3 GPH (gallons per hour) or greater at 10 PSI. These leaks are indicated by restricting system delivery to 3 GPM (gallons per minute) or less at pump pressure of up to 30 PSI in compliance with U.S. EPA requirements 280.41(b) & 280.44(a) for automatic leak detection in pressurized piping. After installation, the user of the leak detector must monitor system delivery levels to ensure that any restricted delivery of fuel, signaling a leak in the pipeline, is dealt with promptly.

The STP-MLD-HC & -HCD units test the delivery pipeline system up to the solenoid valve in the dispenser for leaks whenever the static system pressure has fallen to one PSI or less, and within 3 to 4 seconds (depending on model) allows full flow if the system has no leaks. A leak smaller than the required 3 GPH detection level, any air or vapor trapped in the system, or systems with pressure below 26 PSI, will lengthen the time before the leak detector allows full flow. The leak detector is not designed to detect leaks from the underground storage tank or the submersible pump.

The STP-MLD-HC, blue in color, is suitable for use with a wide variety of motor fuels including: gasoline, diesel fuels, kerosene, fuel oil, jet fuel, avgas, and gasoline-alcohol blends with concentrations of 0% - 100% ethanol or methanol, 20% MTBE with 80% gasoline, or 17% TAME with 83% gasoline. STP-MLD-HCD's, which are tan, are for use with diesel fuel and kerosene only. The STP-MLD-HC adapter tee should be used for both STP-MLD-HC's and STP-MLD-HCD's. While a wide variety of motor fuels may be used with either a STP-MLD-HC or -HCD, the maximum liquid viscosity for a product is 70 S.S.U. at 60°F. Using our MLDs in liquids other than those mentioned above has not been tested. The reaction of other liquids with a pump's seals and wetted surfaces is unknown, and a hazardous situation may result from the use of such liquids.

The STP-MLD-HC & -HCD units mount into a straight threaded leak detector port provided in a special adapter tee housing and may be installed in any position. The piston chamber of the leak detector must be vented to the tank. If your submersible pump does not have a "tank" port, the pump will have to be replaced, a threaded riser must be used, or a different leak detector must be used.

All mechanical leak detectors must be tested upon startup, and routinely thereafter (at least annually) under NFPA standards. These NFPA and other industry testing practices must be followed by the installer and the end user.

A leak detector is not a substitute for compliance with prudent industry practices. Fuel inventory reconciliation checks must be performed on a daily basis by comparing dispenser meter totalizers with fuel volume changes in the underground tank.

Caution  **Installation of two or more STP-MLD-HC's or -HCD's in parallel into the same product piping system will result in the smallest leak that is detectable being greater than the EPA requirements. Each STP-MLD-HC or -HCD will detect a leak of 3gph or greater. If two STP-MLD-HC's are in parallel, a leak of 6 gph will be the smallest leak that will be capable of being detected. If three STP-MLD-HC's or -HCD's are in parallel, a leak of 9 gph will be the smallest leak that is capable of being detected, and so on.**

Third party tests have approved the use of STP-MLD-HC's and STP-MLD-HCD's for:

- Maximum of 396.6 gallons for rigid pipelines.
- Maximum of 95.5 gallons for flexible pipelines.
- Maximum of 492.1 gallons for combination of rigid and flexible pipelines (rigid portion cannot exceed 396.6 gallons and flexible portion cannot exceed 95.5 gallons).

STP-MLD-HC & STP-MLD-HCD Pipeline Capacity

Flexible or Rigid Pipe	Pipe Diameter							
	1"	1 ½"	1 ¾"	2"	2 ½"	3"	4"	5"
max rigid pipe feet	9720	4320	3174	2430	1555	1080	607	380
max flexible pipe feet	2340	1040	764	585	374	260	146	90

Preparation

Note: A precision line test must be conducted before installing a leak detector for the first time. A precision line test is also recommended before replacing a leak detector that is having slow flow (tripping) problems to assure line integrity.

Warning  Before commencing the installation of a leak detector, use safety cones, barricades, trucks, etc. to isolate the work area.

Caution  STP-MLD-HC & -HCD units are designed to detect leaks from where the leak detector is installed and downstream of it. A leak in the piping upstream of the STP-MLD-HC or -HCD, which includes the pump, would require a second means of monitoring to be detected. Thus, install the STP-MLD-HC or -HCD as close to the pump as possible to minimize upstream piping.

Adapter Tee Installation Instructions

Note: If the Adapter Tee is already installed, skip ahead to Step 5.

1. Disconnect power to the submersible pump at the electrical supply box (if already installed).
2. Tag and lock out electrical circuit breakers so they are not accidentally turned on.

Warning  If the electrical circuit breakers are accidentally turned on while installing a leak detector, there is the possibility of ignition of hydrocarbon vapors, and/or the installer being bathed in fuel, which could result in serious personal injury or death. ALWAYS tag and lock out breakers so they are not turned on accidentally.

3. Remove the plastic thread protectors from the inlet and outlet of the adapter tee, see Figure 2. Install the adapter tee into the pipeline with the inlet side 3" male NPT towards the supply pump and the 3" female NPT discharge to the dispensing equipment. Apply UL-classified non-hardening, non-toxic pipe thread sealant to all the NPT pipeline connections.

Warning  The adapter tee is normally provided from the factory, with an adapter tee cover in the leak detector mounting port. Be sure the cover is properly installed prior to proceeding to step 4. Failure to do so could result in a leak of fuel contaminating the environment, property damage, and/or cause serious personal injury or death.

4. Turn power on at the load center and turn on the submerged pump at a dispenser and purge air from the system. Look for leaks at the parts just worked on. If there are any leaks, immediately turn off the power at the load center, tag and lock out the breaker, and repair the leaks.

Leak Detector Installation Instructions

Note: Before installing the leak detector, purge the system of any air by running the pump and delivering gasoline from each dispenser (starting with the dispenser farthest from the pump), until all air is removed. The leak detector will not work properly until all of the air is out of the system.

5. Disconnect power to the submersible pump at the electrical supply box.
6. Tag and lock out electrical circuit breakers so they are not accidentally turned on.

Warning  If the electrical circuit breakers are accidentally turned on while installing a leak detector, there is the possibility of ignition of hydrocarbon vapors, and/or the installer being bathed in gasoline, which could result in serious personal injury or death. ALWAYS tag and lock out breakers so they are not turned on accidentally.

7. Remove the plastic o-ring protector from the bottom of the leak detector, see Figure 2.

Caution  Relieve line pressure by using the manual pressure relief (if present), or by loosening a pipe plug either on the line side of the submersible manifold or in the shear valve under a dispenser. Make adequate provision to trap the liquid that escapes to prevent contamination of the environment. Re-tighten the pipe plug or manual pressure relief.

8. Remove the adapter tee cover, see Figure 2. Lubricate the cover o-rings, the threads, and unpainted surfaces with grease and leave the cover inside the sump for future use, if necessary.

9. Examine the straight bore below the straight threads for roughness caused by corrosion. If rough, contact FE Petro Technical Support for further instructions.
10. Screw the leak detector into the adapter tee, and tighten with a 1-½" socket or pipe wrench on its hex top. The STP-MLD-HC or -HCD must be screwed completely into the adapter tee to provide a good seal.
11. Remove the plastic dust cover from the vent port at the top of the leak detector, see Figure 2.
12. Remove the 1/4-inch plug from the TANK PORT on the pump. Apply UL-classified, non-hardening, non-toxic pipe thread sealant to the threads on the tubing fitting and install one 90° fitting in the leak detector vent port and either a 90° or straight fitting in the tank port.

Caution  **Take steps to prevent any foreign materials from getting into the top of the leak detector as damage to the sealing surfaces in the piston area could result, preventing the leak detector from operating correctly.**

Caution  **The FE Petro STP/ISTs have several ports. The leak detector must be vented to the tank port only. This is the port closest to the tank. Do not connect a leak detector to the syphon port, as this will make the leak detector inoperative, causing it to be incapable of detecting a leak, with resulting risk of contamination of the environment. Also, do not vent the leak detector to a pressure port, as this will keep the unit from operating properly.**

13. Install the copper tube packed with the STP-MLD-HC into the compression fittings just installed in step 12 above, and firmly tighten. The tubing may be shortened if necessary.

Caution  **This line vents the air displaced by piston travel, and drains any liquid, which may leak past the piston seal. When installing this tubing make sure it is not crimped and that it will drain properly to the tank, or the leak detector will not open properly and could give a false indication of a leak. Failure to install and connect this tubing could result in environmental contamination.**

14. Turn power on at the load center and turn on the submerged pump at a dispenser. Look for leaks at the parts just worked on. If there are any leaks, immediately turn off the power at the load center, tag and lock out the breaker, and repair the leaks.
15. Purge remaining air from the system as follows: Turn on power at the load center, and dispense enough product from the dispenser furthest from the pump to remove all the air from that line. Repeat this procedure with each dispenser, working your way back to the pump. (other methods may be used as long as the air is removed). The STP-MLD-HC or -HCD will not work properly if all of the air is not removed from the system.

Note: If, on dispensing fuel in step 15 above, you find the flow restricted to 1.5 to 3 GPM, the leak detector has not opened. This could be due to air trapped in the system. Turn on the submersible pump at the dispenser but do not dispense any fuel. Wait approximately 2-3 minutes. If the line is leak free the pump will pressurize the system opening the STP-MLD-HC or -HCD, then purge the air from all dispensers as in step 15 above.

Note: This leak detector should perform a line leak test within 3-5 seconds from the time the submersible pump is turned on at the dispenser. Air or vapor in the system will cause this time to be longer in proportion to the amount of air or vapor in the lines. If the nozzle is opened before the completion of the line test, the leak detector will detect this opening as a leak and restricted flow will result. Close the nozzle for a period of time to allow completion of the line test, and the leak detector will allow full flow again, provided there is no other escape of fuel.

STP-MLD Line Leak Testing

Note: To properly check a line leak detector the following is required: a graduated cylinder (usually graduated in milliliters) of approximately 300 ml volume, a test fixture which allows a leak of 3 GPH at 10 PSI (see Figure 1), and a stop watch or a watch with a seconds hand.

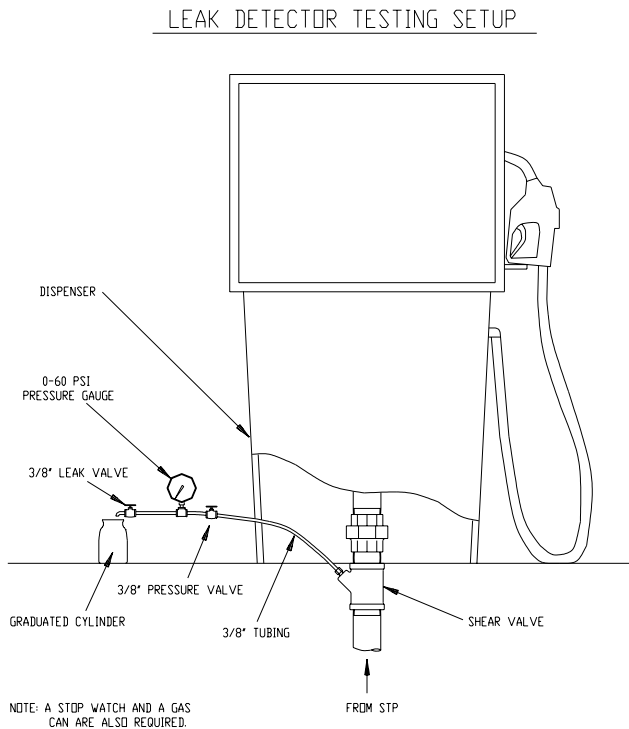

Figure 1

16. Turn the pump off at the load center, relieve the line pressure, and then remove the pipe plug in the shear-valve. Make adequate provision to trap any liquid that escapes to prevent environmental contamination. Install test fixture (pressure gage, leak valve and pressure valve) into the dispenser shear-valve port, see Figure 1. The test fixture will be used to introduce a 3 GPH leak @ 10 PSI.
17. With the leak valve closed, turn on the submersible pump at the load center and at the dispenser and look for leaks at the port of the shear-valve.

Note: If there are any leaks, immediately shut the pump off at both the dispenser and at the load center, tag and lock out the breaker, and eliminate the leaks. Repeat step 17 to verify.

18. Turn the pump off at the dispenser and open both valves, draining the fluid into a suitable container, and observe the pressure dropping to zero. Continue draining until there is no more product coming out. Close the leak valve, turn the pump on at the dispenser and observe the pressure gauge. The pressure should increase quickly up to 20 to 26 PSI, and hesitate for 1-4 seconds or longer if there is air or vapor trapped in the system, and then increase to full pump pressure.

19. With the submersible pump on, adjust the leak valve and pressure valve simultaneously until 10 PSI and 3 gph or less are attained, while draining the fluid into a suitable container. To verify the leak, catch the output product into a graduated cylinder for 60 seconds (or the equivalent product measurement for a shorter time period, i.e., 94 milliliters at 30 seconds = 188 milliliters per 60 seconds). Turn off the pump and calculate the leak rate detected as follows:

$$\text{Leak Rate GPH} = \{ (\text{milliliters of fuel caught} / 60 \text{ seconds}) \times .95 \}$$

Note: The detected leak rate must be set to 3 GPH or less per EPA standards. If the leak rate needs to be adjusted, repeat step 19 while increasing or decreasing the leak rate and maintaining 10 PSI at the pressure gage.

20. Once the leak rate is established, do NOT adjust the leak valve. Open the pressure valve all the way and allow the line pressure to drop to zero. Leave the pressure valve open all the way. Continue to drain until there is no more product draining. Turn the submersible pump on at the dispenser and direct the fluid into a suitable container while observing the pressure gauge, which should not increase above 26 PSI. Turn the submersible pump off and wait at least one minute. Turn the submersible pump back on at the dispenser and observe that the pressure does not increase above 26 PSI. This step verifies the leak detector has detected a leak equivalent to approximately 3 GPH @ 10 PSI as required by the EPA.
21. Close the leak valve and observe the pressure increase to full pump pressure. Turn the submersible pump off and drain the pressure back to zero.
22. Turn the pump off at the load center, and remove the test fixture, and replace the pipe plug after applying UL-classified, non-hardening, non-toxic pipe thread sealant.

STP-MLD-HC Line Leak Indicator Testing

23. As a final check to assure the leak detector has been installed and is working properly, before leaving the station perform the following check **(it takes two people to perform this check)**:
- Turn the submersible pump on at the dispenser. Dispense product into a five-gallon container to assure full flow is being obtained.
 - Leaving the dispenser switch turned on, **turn the power off at the submersible pump circuit breaker (load center) and open the nozzle to release pressure.** Let stand idle for approximately 15-30 seconds.
 - With the nozzle open, turn on the power at the submersible pump circuit breaker (load center). The flow out of the still open nozzle should be no more than 3 GPM.
 - Close the nozzle with the submersible pump still running and wait for 15 seconds or until you feel the pressure increase in the line when the leak detector opens. Open the nozzle and full flow should be obtained.

Note: The submersible pumps and the dispensers must be wired to different circuit breakers for the above test to work. Also, some dispensers may not allow for this test since low pressure may put it into error (i.e. blender dispensers).

Note: Instructions 16 through 23 can also be used to check a leak detector after it has been in service for a period of time to assure it is functioning properly. Mechanical line leak detectors are devices that are subject to wear with usage. However, FE Petro always recommends that the leak detector is in compliance with US EPA requirements.

If the above results cannot be obtained, review the installation instructions to assure the leak detector was installed properly. If everything has been done correctly and the results still cannot be obtained, contact the FE Petro Technical Service at (800) 225-9787.

Figure 2



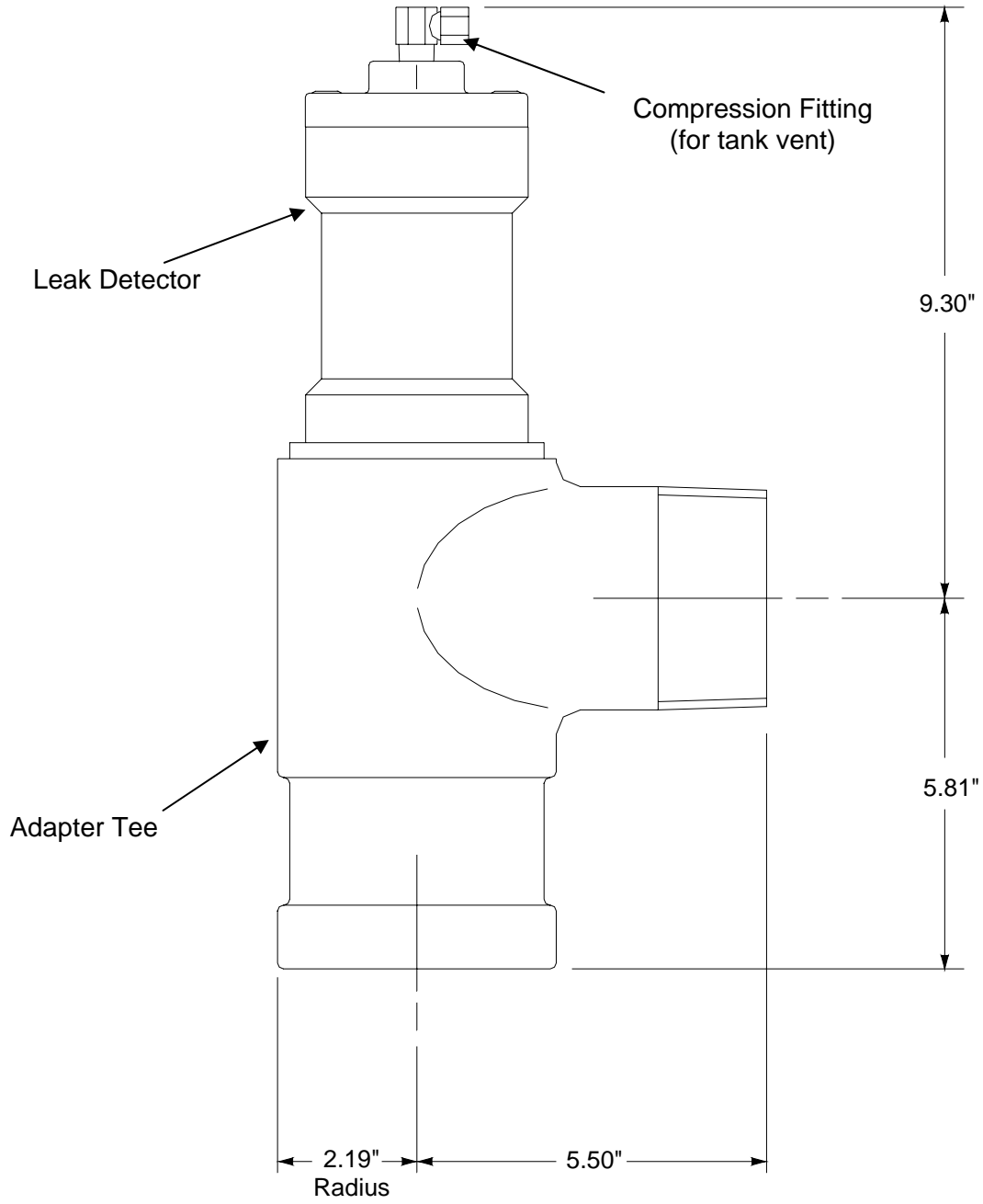
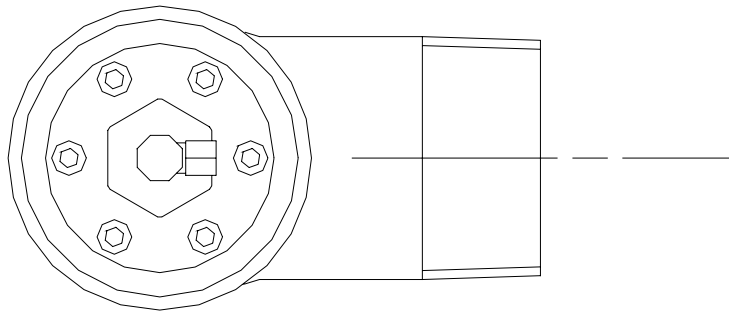

Figure 3

Troubleshooting

Problem

Slow Flow (STP-MLD-HC is in the Tripped position only allowing 3 GPM or less flow rate)

Possible Causes

1. System leak (i.e., line, dispenser, STP/IST, etc.)
2. Thermal contraction
3. No time delays in dispensers or not set correctly
4. Incorrect STP-MLD-HC version
5. Tank empty/air in lines
6. Power to STP is off or defective dispenser switch signal (hook)
7. Defective STP-MLD-HC

Actions

1. Visually inspect all areas for leaking product.
2. Insert a pressure gauge in shear valve.
3. Cycle the pump to confirm that the system is holding pressure. If pressure is not holding, conduct a line test through the STP/IST. If there are any system leaks, repair, then retest the system. If system has no leaks (line or submersible), thermal contraction may be a possible cause. Continue to the next step.
4. Test for thermal contraction per FE Petro Technical Bulletin TB001. If thermal contraction has been verified, continue with the next step.
5. Find the opening time (test cycle) of the STP-MLD-HC. Follow step 18 and time how long it takes from when the submersible pump is turned on until it reaches full pump pressure. The STP-MLD-HC and STP-MLD-HC-D models typically take 3 - 5 seconds. If the test time is not within these specifications, it is possible that there is a line leak, air/vapor in the line or not using the correct STP-MLD-HC model for the installation, thus causing the opening time to increase. Cycle the power and time the number of seconds it takes for the solenoid valve in the dispenser to "click" open, this is an audible indicator and usually easy to hear. This time must be approximately two seconds greater than leak detector opening time. Consult dispenser manuals for solenoid time delay installation or adjustment.
6. If problems continue, contact FE Petro Technical Support at 1-800-225-9787.

Problem

Not catching a 3 GPH leak at 10 PSI

Possible Causes

1. Air/Vapor in system
2. STP-MLD-HC installed incorrectly
3. Using the incorrect STP-MLD-HC version
4. Testing procedure
5. Defective STP-MLD-HC

Actions

1. Make sure all air/vapor in the system has been purged, see step 15. If no air/vapor is present continue with next step.
2. Make sure STP-MLD-HC is installed correctly:
 - a. STP-MLD-HC must be installed in leak detector port on submersible pump manifold or adapter tee housing and make sure the O-ring is present and not damaged
 - b. The vapor tube must be installed and vented back to the tank port from the STP-MLD-HC
 - c. Make sure there are not any in-line check valves between the dispenser solenoid valve and the STP-MLD-HC
 - d. If a manifolded system, only one submersible pump can turn on at a time during the leak testing cycle
 - e. There must be less than 12 feet of static head in the system
3. Make sure the correct STP-MLD-HC model is being used for the application (product and piping).
4. Is the leak testing fixture calibrated correctly (3 GPH leak @ 10 PSI). Has the STP-MLD-HC been fully tripped before testing, see step 20.
5. If problems continue, contact FE Petro Technical Support at (800) 225-9787.

Note: If a STP-MLD-HC does not operate correctly, or there are any questions concerning installation or service, please contact FE Petro Technical Service at (800) 225-9787.

This page intentionally left blank

This page intentionally left blank



FE PETRO[®]

Franklin Fueling Systems

3760 Marsh Road • Madison, WI 53718 U.S.A.

Tel: +1 608 838 8786 • Fax: +1 608 838 6433 • www.franklinfueling.com

Tel: USA & Canada 1 800 225 9787 • Tel: Mexico 001 800 738 7610