



702/703 Spill Containment Installation Instructions

Please Read Before Installing

Note: The 703-400-01 model features a stainless steel containment tank. In the state of Florida, EBW approves the installation of the 703 spill container with the following instructions:

1. Dig around the existing riser pipe to the desired depth.
2. Clean the riser pipe to eliminate any sand, scalding or rust.
3. Apply a layer of duct tape around the threads at the top of the riser pipe to protect the gasket.
4. Slip the manhole assembly over the riser pipe to the approximate depth.
5. Lubricate the pipe & gasket to allow the gasket to slide easily. Slip the gasket over the riser pipe and position it in the clamp ring insert.
6. Slip the clamp plate into position over the clamp ring and install the six 5/16" - 18 nuts, but DO NOT tighten them at this time.
7. Position the spill containment at the proper height, back fill, and tighten the six nuts in the clamp ring.
8. Remove the duct tape from the riser pipe, then install the tight fill adaptor and cap.
9. Backfill area surrounding containment basin to sub-grade. Install concrete around spill containment manhole to required grade levels.

Note: In the state of Florida the entire stainless steel containment needs to be encapsulated in concrete.

Check for Leaks

Every unit should be tested for leaks prior to, and after, pouring the concrete. Fill the unit completely with water. If the test water level drops at all within one hour, then a leak exists.

If the unit continues to leak, the entire spill container should be removed from the riser pipe and replaced with another. **RE-TEST.**

After the concrete has been poured, **RE-TEST** to make sure that no damage occurred during installation.

Drawings on Reverse

702/703 Grade Level / Pump Out Spill Containment Illustration 702-400-01/703-400-01

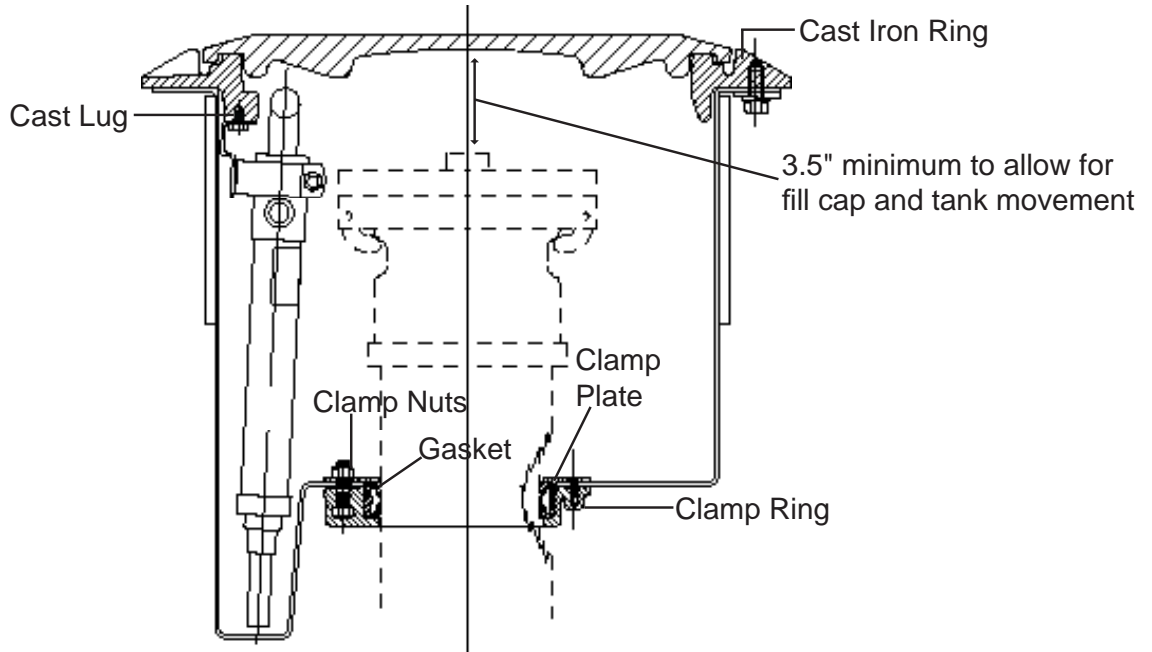

702 Below Grade Level / Pump Out Spill Containment Illustration 702-450-01

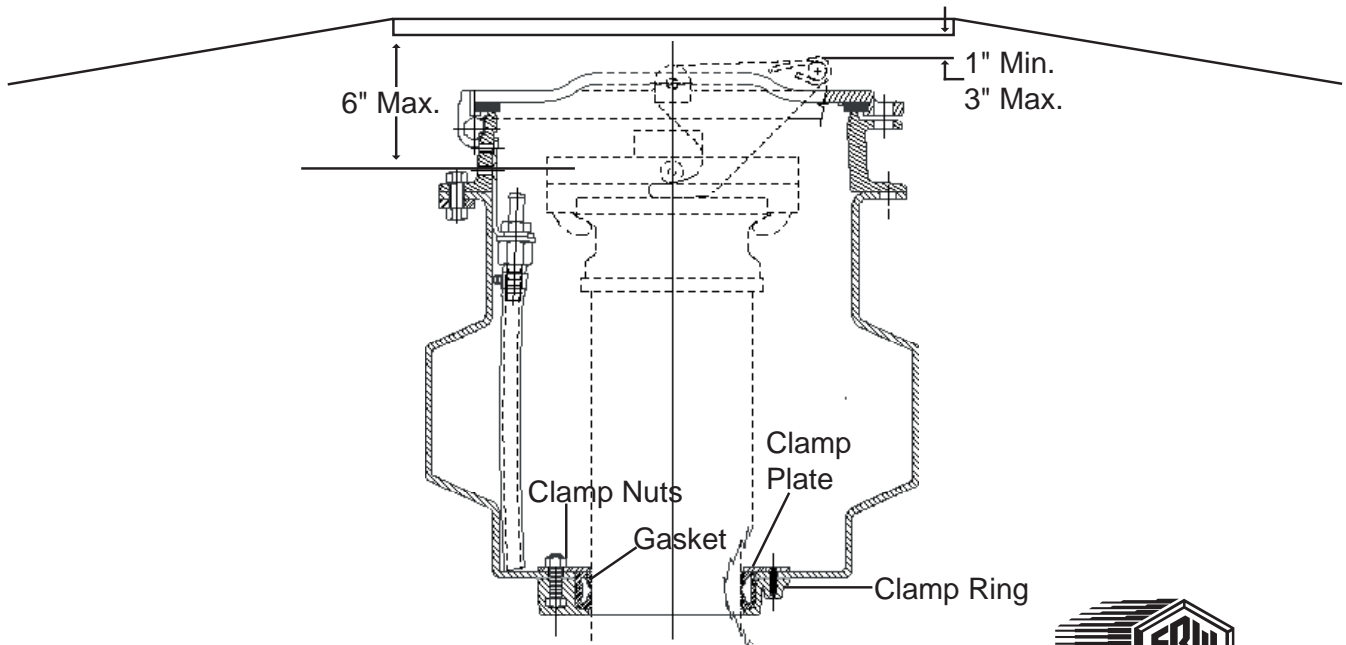

Franklin Fueling Systems

3760 Marsh Road • Madison, WI 53718 U.S.A.

Tel: +1 608 838 8786 • Fax: +1 608 838 6433 • www.franklinfueling.com

Tel: USA & Canada 1 800 225 9787 • Tel: Mexico 001 800 738 7610

