

Pressure Regulator Valve Model-664

Installation Instructions

The model 664 Pressure Regulator Valve is designed for use with suction type dispensers. The model 664 Pressure Regulator Valve is intended to be used with above ground storage tank systems, or in Booster Systems with a submerged pump in an under ground tank. The model 664 Pressure Regulator valve is designed for fueling systems with a maximum pressure or 50 P.S.I.

DANGER



Gasoline and petroleum products are explosive and flammable. To prevent personal injury or death, damage to equipment or property, follow proper safety precautions when installing or servicing EBW equipment.

The model 664 Valve must be securely anchored to island or dispenser with the shear section level with the base of dispenser and top surface of island (See figure 1). It can be mounted to a Stabilizer Bar Kit (figure 2) using mounting bracket 664-304-01.

When installing the Pressure Regulator Valve to piping, always apply a wrench between the valve shear section and the pipe being tightened to prevent shear section damage.

Install Pressure Relief Valve

All valves used with the model 664 valve must be equipped with thermal expansion relief valves to prevent damage to the Pressure Regulator Valve or piping, which could cause loss of product and contamination of the environment. Thermal expansion can create pressures in excess of the model 664 maximum pressure of 50 P.S.I., and result in valve failure.

Run piping from the valve vent to be terminated at an elevation equal to the top of storage tank or suction pump, whichever is higher. Vent must be open to atmosphere.

If a solenoid valve is used with the model 664 Pressure Regulator Valve, it must be wired so the solenoid valve is open only when the pump motor is running!

Installation of the model 664 Pressure Regulator Valve and other piping components must be in accordance with the latest National Fire Protection Association Codes, N.F.P.A.-30 and N.F.P.A-30A.

N.F.P.A. 30 Para 2-2.7-1 revision requires a shut off or gate valve. This valve is used to close the system and prevent product loss when equipment downstream of the above ground tank is being maintained or replaced.

N.F.P.A. 30 A Para 2-1.7 revision requires the tank outlet be equipped with a device, such as a solenoid valve or antisiphon valve, positioned adjacent to and downstream from the gate or shut off valve. This must be installed and adjusted such that liquid cannot flow by gravity or siphon from the tank in case of piping or hose failure when the dispenser is not in use.

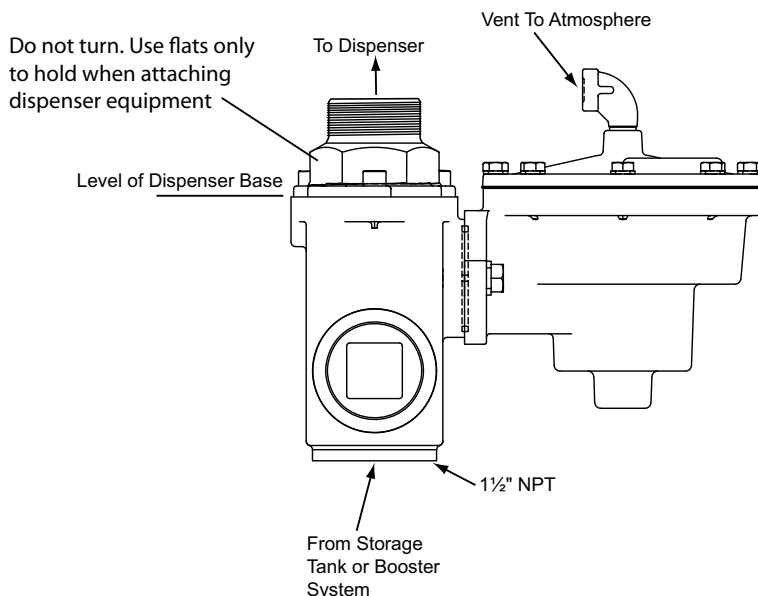

Figure 1: 644 Valve Side View

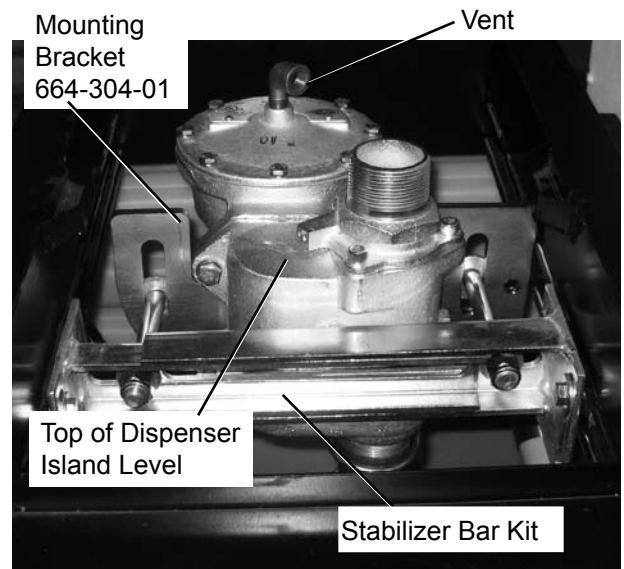

Figure 2: 644 Valve Installation

NOTE:

All valves (anti-syphon, solenoid, and shut off) used with model-664 valve must be equipped with thermal expansion relief valves.

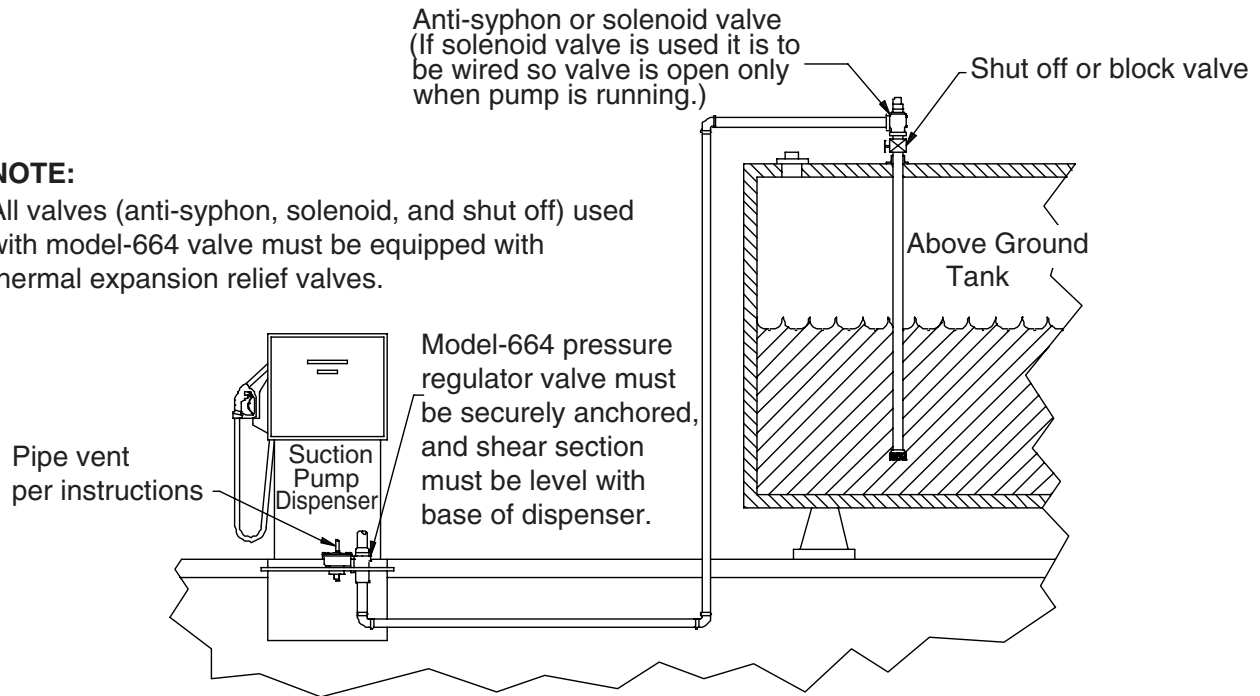

Figure 3: Installation with Above-Ground Tank

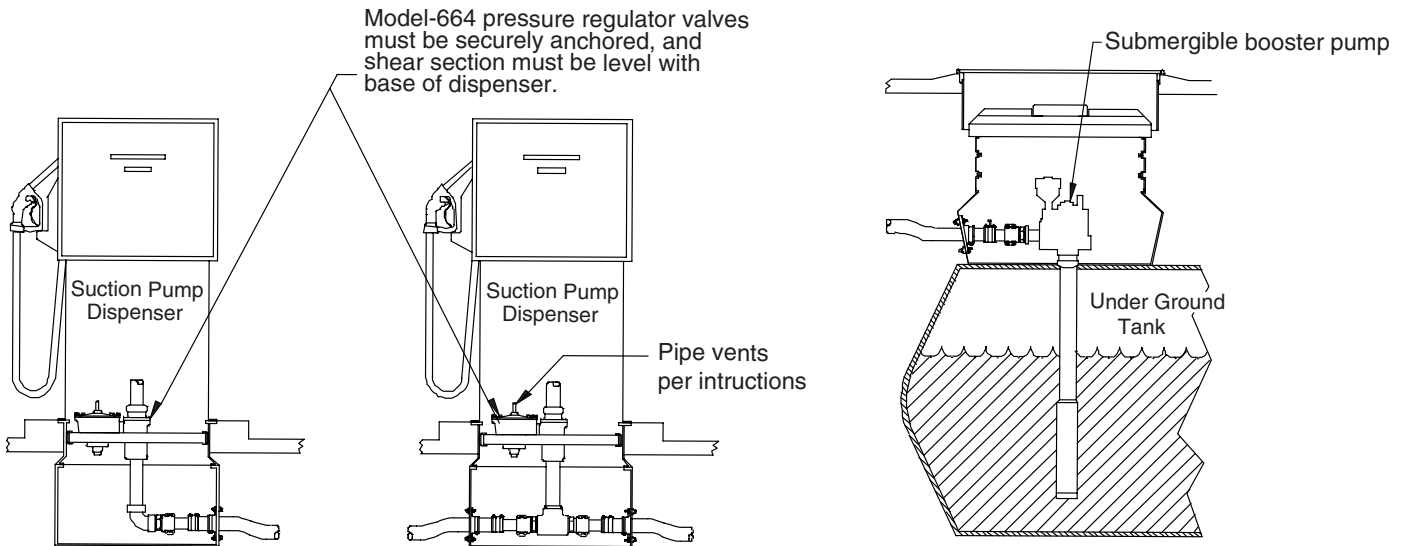

Figure 4: Booster System Installation



Franklin Fueling Systems

3760 Marsh Road
Madison, WI 53718, U.S.A.
Tel: +1 608 838 8786
Tel: USA & Canada 1 800 225 9787
Tel: Mexico 001 800 738 7610
www.franklinfueling.com