

Pull to Push Drain Assembly Kit

Installation Instructions

Note: This kit can only be used to replace existing 705-215 series manual push drains or 705-223 series cover actuated push drains.

Procedure

1. Remove the existing valve assembly and mounting screws. Discard them.
2. Trim the existing gasket using the retainer plate as a guide.
3. Attach the chain assembly to the valve lever, and slide the screen upward on the valve to allow clearance for the mounting screws.
4. Align the mounting screw holes and place the new gasket in position.
5. Install the new valve assembly using the two 1/4 - 20 x 1.00 hex head screws. **Do not over tighten.**
6. Slide the screen back into position.

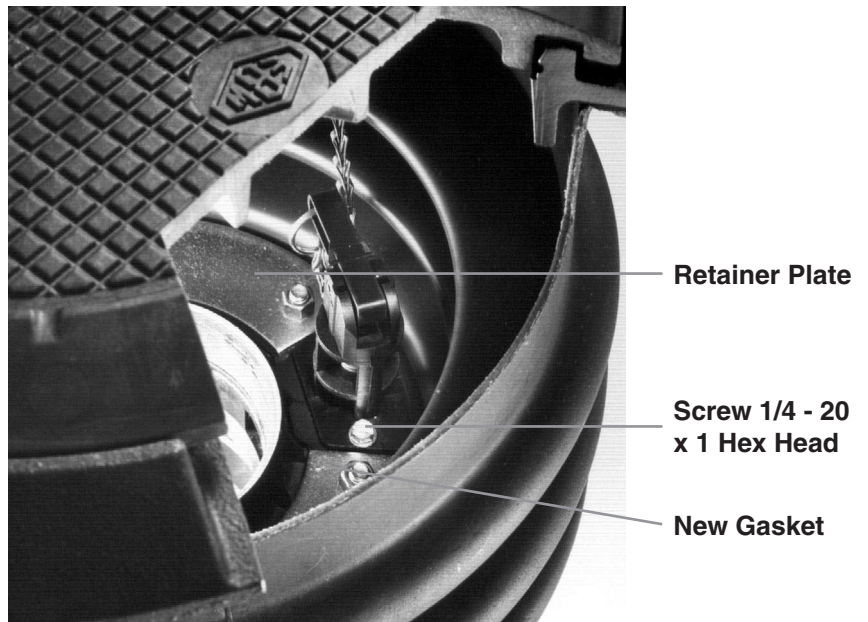

Below Grade Units with 705-215 Series Manual Push Drains

Procedure

1. Install the new chain anchor bracket using the stainless steel hose clamp. Position the clamp directly under the fill adapter on the riser pipe, and line up the hole in the bracket with the valve operation lever (see Figure 1).
2. Remove the ring from the chain assembly, and slip the chain through the bracket as shown.
3. Cut the chain to length, but allow enough slack for tank movement and proper valve operation.
4. Replace the ring.

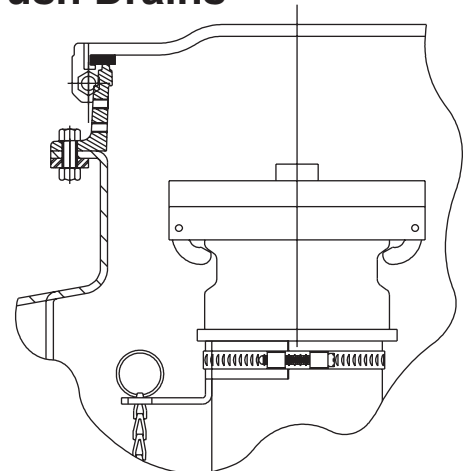
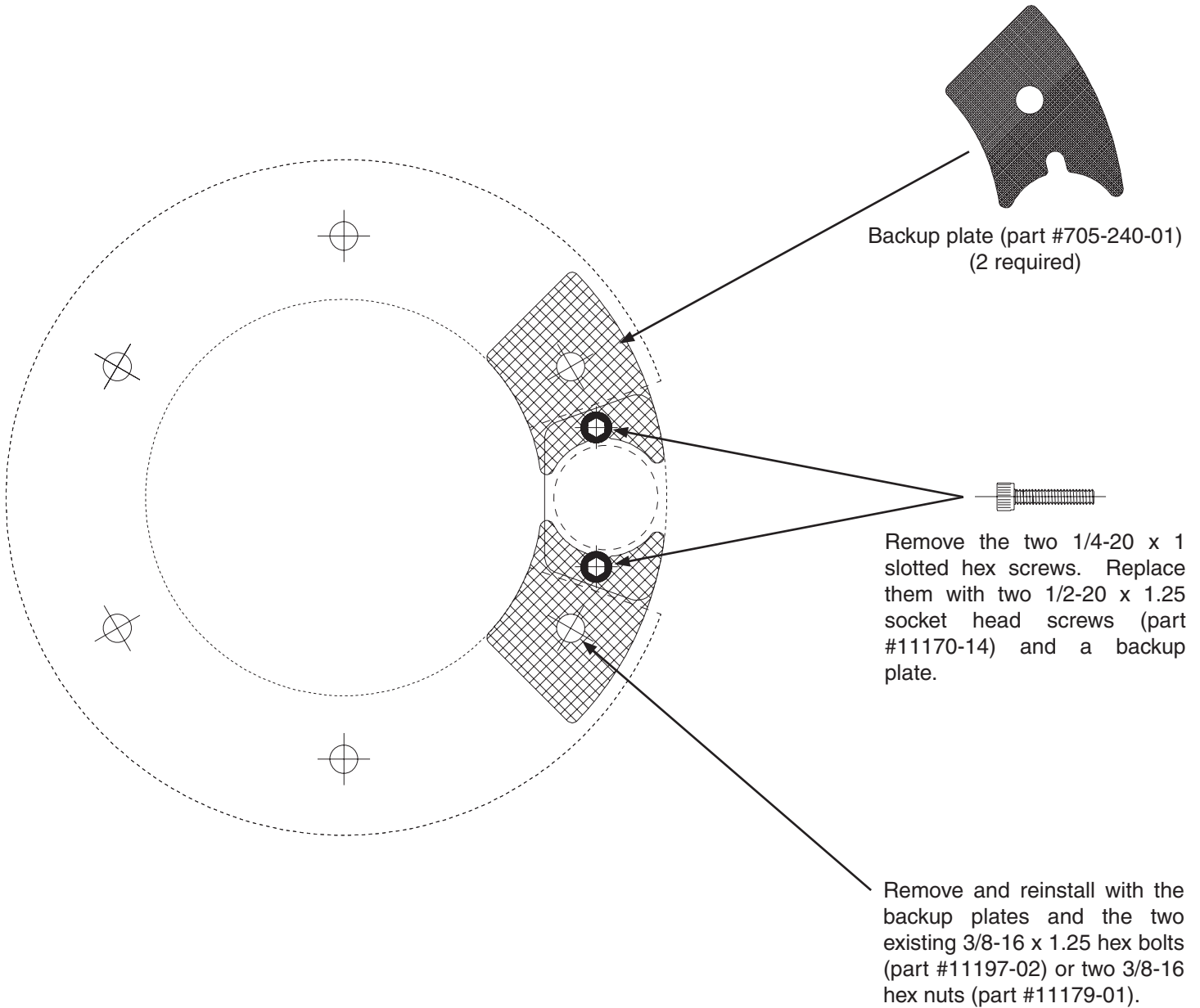

Figure 1

Spill Containment Drain Valve Replacement



Franklin Fueling Systems

3760 Marsh Road • Madison, WI 53718 U.S.A.

Tel: +1 608 838 8786 • Fax: +1 608 838 6433 • www.franklinfueling.com

Tel: USA & Canada 1 800 225 9787 • Tel: Mexico 001 800 738 7610

