



702 SPILL CONTAINMENT

INSTALLATION INSTRUCTIONS

for 3" Riser Pipes

Please Read Before Installing

1. Dig around the existing riser pipe to the desired depth.
2. Clean riser pipe to eliminate any sand, scaling and rust.
3. Apply a layer of duct tape around the threads at the top of the riser pipe to protect the gasket.
4. Install self adhesive gasket in bottom of clamp ring insert with adhesive side down. Place insert in with opened end up.
5. Slip the manhole assembly over the riser pipe to the approximate depth.
6. Lubricate the pipe & gasket to allow the gasket to slide easily. Slip the gasket over the riser pipe and position it in the clamp ring insert.
7. Slip the clamp plate into position over the clamp ring and install the six 5/16" - 18 nuts (DO NOT tighten at this time).
8. Position the spill containment at the proper height, back fill and tighten the 6 nuts in the clamp ring.
9. Remove the duct tape from the riser pipe, install the tight fill adaptor and cap.

CHECK FOR LEAKS

Every unit should be tested for leaks prior to, and after pouring the concrete. Fill the unit completely with water. If the test water level drops at all within one hour, then a leak exists.

If the unit continues to leak, the entire spill container should be removed from the riser pipe and replaced with another. RETEST.

After the concrete has been poured, RETEST to make sure that no damage occurred during installation.

702 GRADE LEVEL / PUMP OUT SPILL CONTAINMENT ILLUSTRATION 702-413-01

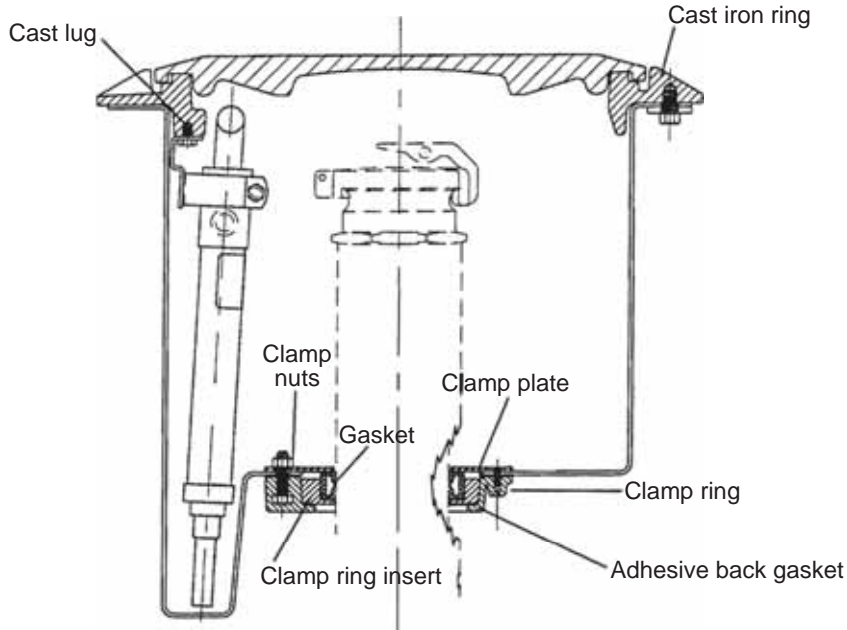

702 BELOW GRADE LEVEL SPILL CONTAINMENT ILLUSTRATION 702-463-01

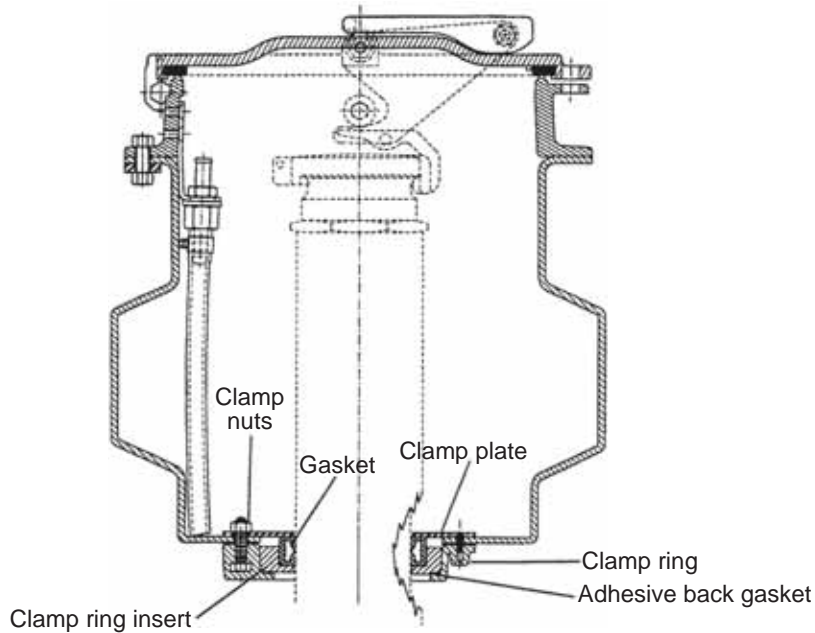

Franklin Fueling Systems

3760 Marsh Road
Madison, WI 53718, U.S.A.
Tel: +1 608 838 8786
Tel: USA & Canada 1 800 225 9787
Tel: Mexico 001 800 738 7610
www.franklinfueling.com