





# Warden<sup>®</sup> AST Overfill Prevention Device

## Installation Instructions

**Warning**  Failure to follow instructions or substitution of parts other than those supplied by EBW, may cause failure of the device which may create a hazardous condition and/or environmental damage. Check to make sure all parts have been provided before starting installation.

**Warning**  EBW products should be used in compliance with applicable federal, state, and local laws and regulations. When no other regulations apply, follow NFPA codes 30, 30A and 70 from the National Fire Protection Association. Product selection should be based on physical specifications and limitations and compatibility with the environment and material to be handled. EBW makes no warranty or fitness for a particular use.

**Warning**  In order to prevent product spillage from the aboveground storage tank (AST), properly maintained delivery equipment and a proper tight fill connection are essential. Failure to properly connect the delivery hose or disconnecting a pressurized line, will cause a hazardous spill which may result in personal injury, property damage, fire, explosion and/or environmental contamination.



Picture 1

**Product Warranty:** All EBW equipment is thoroughly tested before shipment and guaranteed to the extent of replacing only goods found to be defective in manufacture. We cannot allow claims for labor or consequential damage resulting from purchase, installation, or misapplication of our products.

**Note:** Shutoff points are influenced by the specific gravity of stored liquids. *This valve was designed to be used as an emergency overfill prevention device only!*

**Note:** The Warden AST Overfill Prevention Device is designed for use on Aboveground Storage Tanks (AST). Where the product is pumped from the transport truck to the AST, the prevention device will stop the flow when the level in the tank reaches a predetermined point.

### Packing List

- (1) Hose clamp (708-160-01)
- (1) Valve assembly (709-400-01)
- (1) Instruction manual (F-6128)
- (1) Warning plate (709-211-01)

### Tools Needed for Installation and Assembly (Picture 1)

- Tape measure
- (2) Pipe wrenches
- 1/8" Hex key
- Fuel resistant thread sealant
- Permanent marker
- Hacksaw
- Petroleum jelly

### To Be Supplied By Installer

- 2" NPT coupling (black iron)
- Drop tube of proper length for the tank that the valve is being installed in - 2" NPT threaded one end (black iron)

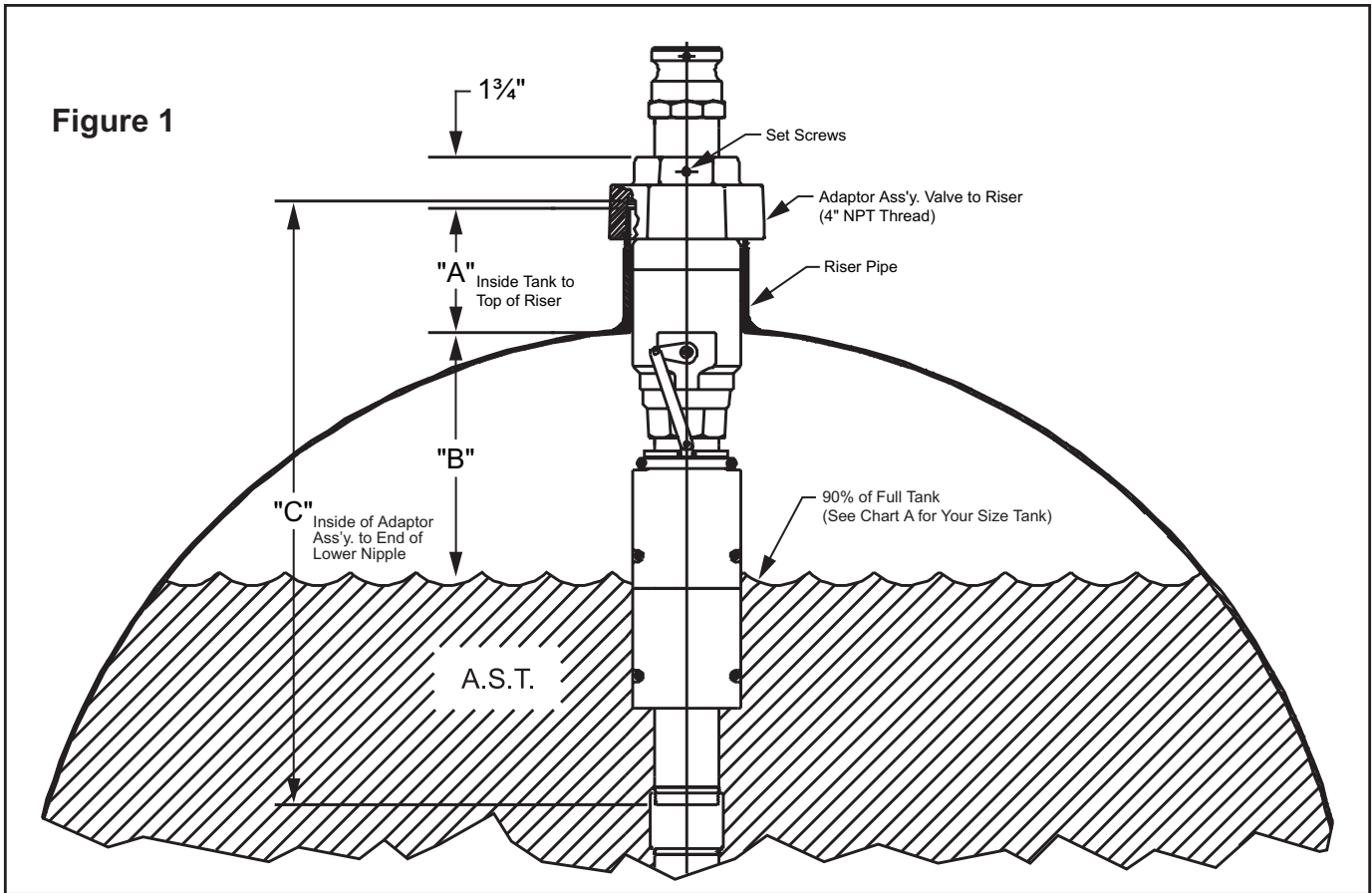

**Note:** The Warden is packaged assembled. The adapter assembly-valve to riser is loosely positioned on the upper 4\"/>

**Installation**

1. Determine the length of the riser pipe. Measure from the inside top of the tank to the top of the riser pipe. See Dimension A in Figure 1.
2. Determine the shutoff point for the aboveground storage tank. Using Chart A below, obtain Dimension B in Figure 1.

**Chart A**

Tank Diameter (in feet)	Approx. Dimension B for 90% Shutoff (in inches)
4	8
5	9¼
6	11½
7	13½
8	15
9	15½
10	19
12	22

**Note:** The chart above is an approximate shutoff point for 90% capacity of round tanks. Using any other shape of tank requires getting the manufacturer’s chart to obtain Dimension B.

3. Add “A” to “B” + 1.75” to obtain the proper position of the valve assembly in relation to the shutoff point in the tank.

$$\frac{\quad}{A} + \frac{\quad}{B} + 1.75" = \text{Shutoff Point}$$

4. Move the float assembly to the full up position. Measure from the center joint on the floats and mark the shutoff point on the upper pipe nipple with a permanent marker (Picture 2). The mark will set the valve assembly in position for shutoff at 90% of tank capacity.

**Note:** If the shutoff mark is above the lower edge of the cam & groove adapter, a longer pipe nipple will need to be installed. See Steps 15 to 20.

5. Move the top edge of the adapter assembly -valve to riser. Align with the shutoff mark, and secure in place by tightening the (3) ¼-20 set screws, with a ⅛" hex key (Picture 3).
6. Determine Dimension D, the distance from the bottom of the tank to the top of the riser pipe, using a tank stick. See Figure 2.
7. Measure from the inside surface of the adapter assembly -valve to riser, to the bottom edge of the lower pipe nipple (Picture 4 – Dimension C, Figure 1). Add 6" (or amount per local codes or requirements) to Dimension C and subtract from Dimension D to get the length of the lower drop tube.

$$\frac{\quad}{\text{"D"}} - (6" + \frac{\quad}{\text{"C"}}) = \text{Lower drop tube length.}$$

8. Cut the lower drop tube to length and thread one end (2" NPT thread, black iron pipe). Cut the lower end of the pipe at a 45° angle. (Picture 5)
9. Apply fuel resistant pipe sealant to the drop tube threads, and assemble the 2" black iron coupling to the drop tube.

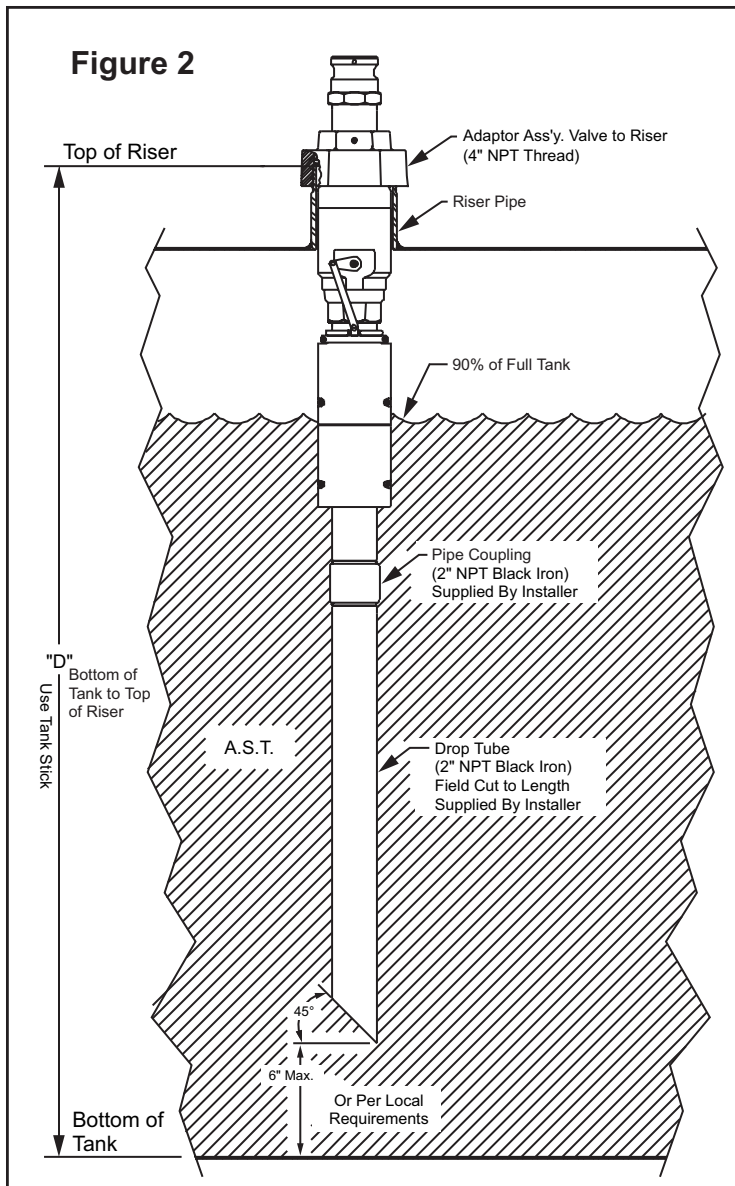

10. Apply fuel resistant pipe sealant to the threads of the lower pipe nipple and assemble the drop tube assembly to the valve (Picture 6).
11. Check the tank riser pipe inside diameter for any burrs, improper reaming, or foreign material. Failure to do so may damage or prevent the valve from functioning. Properly apply fuel resistant pipe sealant to the riser pipe threads.
12. Stand the valve assembly upright and operate the float assembly to make sure that no damage was caused during assembly.
13. Carefully lower the complete valve assembly down the riser pipe (Picture 7). Hold the assembly by the adaptor assembly. Do not force the valve down the riser pipe. If the valve does not fit, the riser pipe will have to be cleaned or deburred before inserting the valve.
14. Thread the adapter and valve assembly to the riser pipe and secure it.

**Note:** If a longer upper pipe nipple is required, use the following steps.

15. Disassemble the upper pipe nipple, adapter assembly-valve to riser, and cam-lock adapter from the valve assembly (Picture 8).
16. Determine the length of the longer upper pipe nipple using the previous Steps 3 and 4.

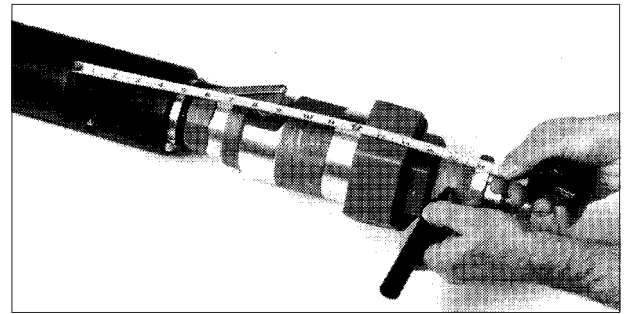

Picture 2

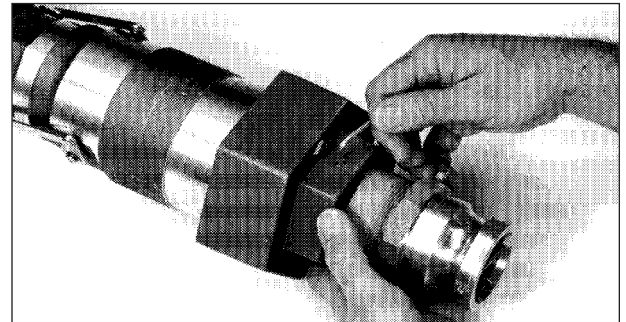

Picture 3

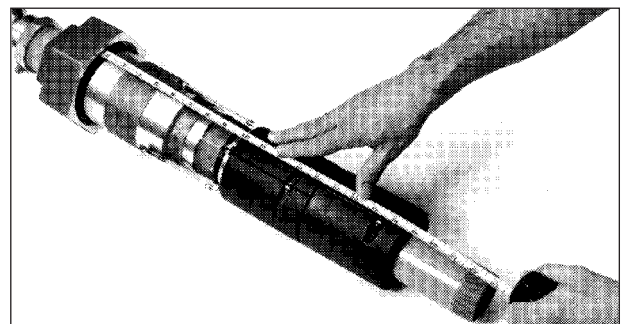

Picture 4

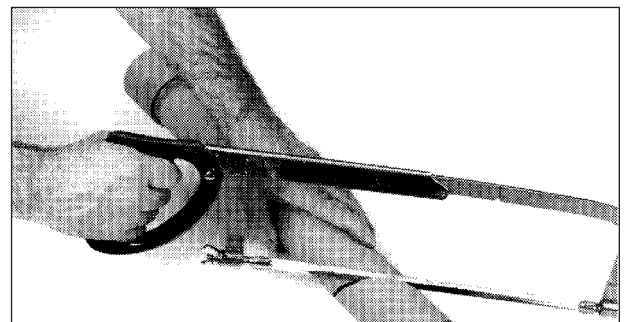

Picture 5

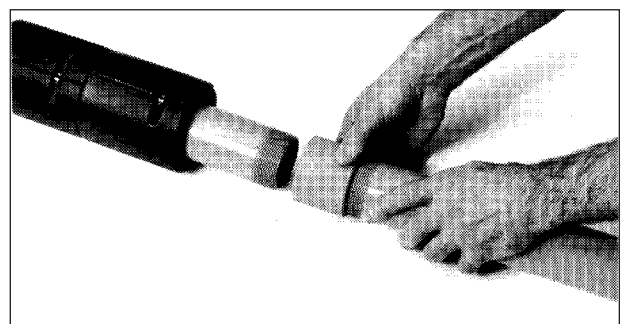

Picture 6

17. Apply fuel resistant pipe sealant to the thread of the longer upper pipe nipple and assemble to the cam lock adapter.
18. Apply a generous amount of grease (Picture 9) to the o-ring in the adapter assembly and slide it onto the nipple with its 4" threaded away from the cam-lock adapter.
19. Apply fuel resistant pipe sealant to the threads of the nipple and assemble to the valve body.
20. Go back to Step 4 and proceed with the normal installation steps 4 through 14.

**Filling Procedure**

1. The nozzle must be equipped with a cam lock coupler to provide a tight fill connection to the Auto Limiter.
2. Attach the coupler to the fill adapter and lock it in place.
3. Turn on the pump.
4. Slowly open the nozzle.
5. A quick jump in the delivery hose indicates that the valve has shutoff.

**Disconnecting Procedures**

1. After the Warden has shutoff, close the nozzle.
2. Turn off the pump.
3. Re-open the nozzle and wait approximately two minutes, which will allow the pressure in the hose to dissipate.
4. Close the nozzle and slowly unlock the coupler.
5. Remove the nozzle and replace the dust cap.

**Warning**  **If the nozzle is disconnected with a pressurized hose, it will cause a hazardous spill.**

**Product Specifications**

**Construction**

Valve Body.....	Aluminum 356-T6
Poppet.....	Aluminum 356-T6
Shaft.....	Stainless Steel
Float.....	High Density Polyethylene
Nipple.....	Epoxy coated black iron pipe

**Flow Rate**

Working Pressure Rating.....	100 psi
Flow Rate 200 gpm.....	@ 20 psi
Minimum Flow Rate.....	No Minimum

**Size (Standard Unit)**

Height of Unit.....	27 3/8"
Compatible Fill Riser.....	4" Fill Riser

**Note:** This overfill prevention device incorporates a pressure relief feature that allows for pressure decay before the nozzle or hose disconnects.

**Note:** The Warden is recommended for use with clean product only. Contaminated product may cause erratic operation or valve failure.



Picture 7

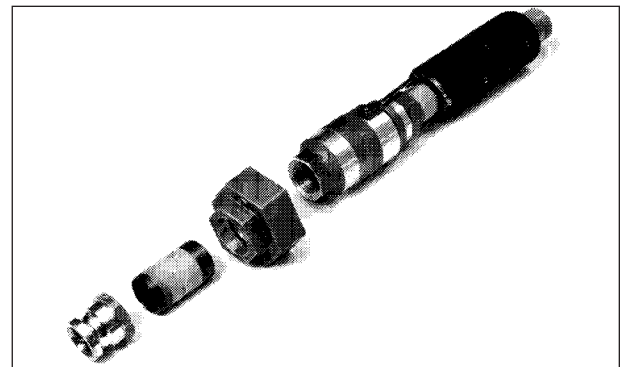

Picture 8

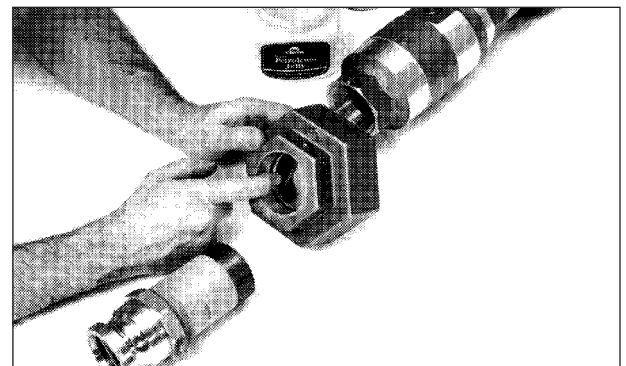

Picture 9



**Franklin Fueling Systems**

3760 Marsh Road • Madison, WI 53718 U.S.A.  
 Tel: +1 608 838 8786 • Fax: +1 608 838 6433 • www.franklinfueling.com  
 Tel: USA & Canada 1 800 225 9787 • Tel: México 001 800 738 7610