

Installation Instructions

90060 DIAPHRAGM SERVICE KIT FOR 664 PRESSURE REGULATOR VALVE

1. CLOSE BLOCK VALVE TO ISOLATE PRESSURE REGULATOR VALVE.
2. REMOVE (8) SCREWS FROM DIAPHRAGM COVER, REMOVE COVER AND DISCARD DIAPHRAGM.
3. REMOVE (3) SCREWS FROM POPPET GUIDE COVER, AND REMOVE ASSEMBLY FROM VALVE BODY. DO NOT SEPARATE GRAY PLUNGER FROM BRASS POPPET.
4. SLIDE POPPET AWAY FROM COVER TO GET ACCESS TO GASKET. REMOVE GASKET AND REPLACE WITH NEW FROM KIT, BEING SURE NEW GASKET IS PROPERLY SEATED IN GROOVE ON POPPET.
5. REMOVE COVER O-RING, AND REPLACE WITH NEW FROM KIT. APPLY LUBE (PETROLEUM JELLY) TO O-RING AND INSTALL AROUND BOSS ON COVER. (LUBE WILL HOLD O-RING IN PLACE FOR ASSEMBLY.)
6. INSTALL POPPET AND COVER ASSEMBLY INTO VALVE BODY, BEING SURE SPRING IS SEATED ON POPPET AND POPPET STEM IS IN GUIDE HOLE. REPLACE (3) SCREWS IN COVER. TORQUE TO APPROX. 6 FT./LB.
7. ALIGN HOLES IN NEW DIAPHRAGM AND COVER WITH HOLES IN VALVE BODY, AND REPLACE (8) SCREWS IN MAIN COVER. TORQUE TO APPROX. 6 FT./LB.
8. OPEN BLOCK VALVE AND CHECK FOR LEAKS.

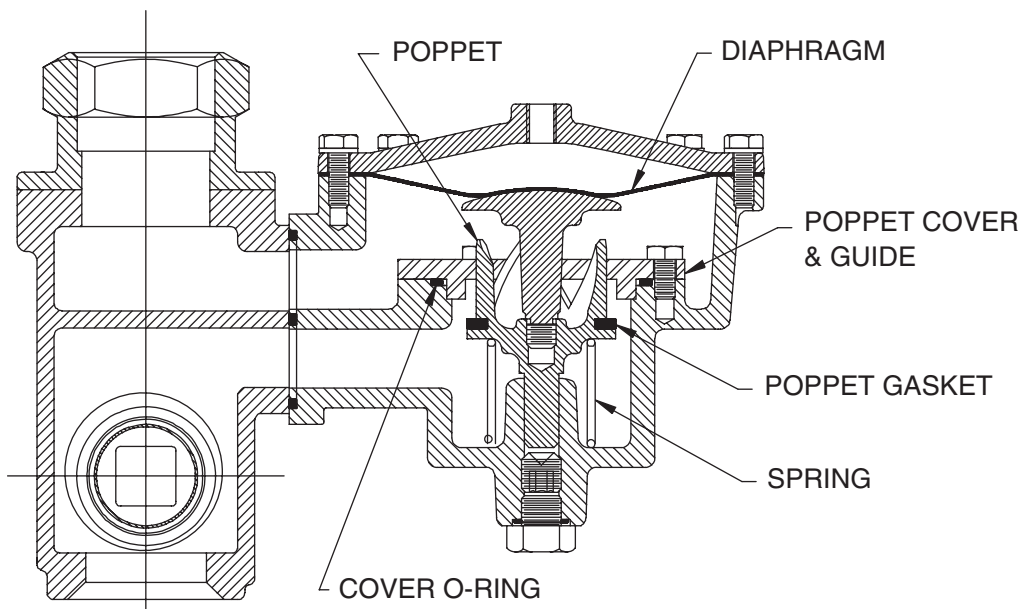

Franklin Fueling Systems

3760 Marsh Road
Madison, WI 53718, U.S.A.

Tel: +1 608 838 8786

Tel: USA & Canada 1 800 225 9787

Tel: Mexico 001 800 738 7610

www.franklinfueling.com