

Double-Poppetted Vapor Shear Valve (p/n 362-206)

Installation Instructions

Important: Correct installation of the vapor shear valve is extremely important to ensure proper operation.

Warning  The valve body must be rigidly anchored to a structural member within the island and dispenser to ensure breakage at the shear section in the event of a severe impact. In the event of a severe impact, failure to provide a rigid mounting to the island and dispenser may result in a break in the outlet pipe, resulting in a hazardous condition. The valve is designed to shear off when a bending movement is applied. When tightening the inlet pipe to the valve, care should be taken so that the force applied is torque and not a bending movement.

Sealing Compound: Apply a U.L. classified, non-hardening gasoline resistant pipe-joint sealing compound on the island riser pipe and dispenser pipe when installing the vapor shear valve. Use sealing compound on a 1" pipe plug and install it into the port not being used. Use sealing compound when removing or reinstalling the test plug.

Attaching Outlet End: Cut the island riser pipe to a length to ensure that the shear section groove is within 1/2" above or below level with the top of the island. Failure to install the shear section groove at this level may prevent the valve from breaking off in the event of a severe impact, resulting in a hazardous condition. Thread the valve hand-tight onto the island riser pipe. To finish tightening it, apply a wrench as shown in Figure 1.

Attaching Inlet End: The dispenser pipe can be connected to the top or side port. Install a pipe plug into the port not being used. Hold the valve steady with one wrench on the surface of the valve. Use the second wrench to tighten the pipe being attached. To finish tightening, apply the wrenches as shown in Figure 2.

Pressure Test Plug: Each valve has been provided with (2) 3/8" NPT pipe plugs for pressure testing the system.

Note: These test inlets are for vapor systems only. Pressure decay low pressure test, 10 inches of water column max.

Damage Due to Impact: Should the valve break or crack due to impact, the valve must be replaced.

Caution  Tighten threads to the following torque specifications:

2" outlet - 90 to 135 ft. lb. 1" inlet - 75 to 100 ft. lb.

Tightening beyond torque limits may crack valve body and allow vapor to leak. Torque values can be obtained by using EBW 901-101-01 chain wrench and a 3/4" drive torque wrench with at least a 125 ft. lb. rating. Due to the chain and torque wrench off-set, actual torque wrench readings for above limits will be:

2" outlet - 75 to 115 ft. lb. 1" inlet - 60 to 85 ft. lb.

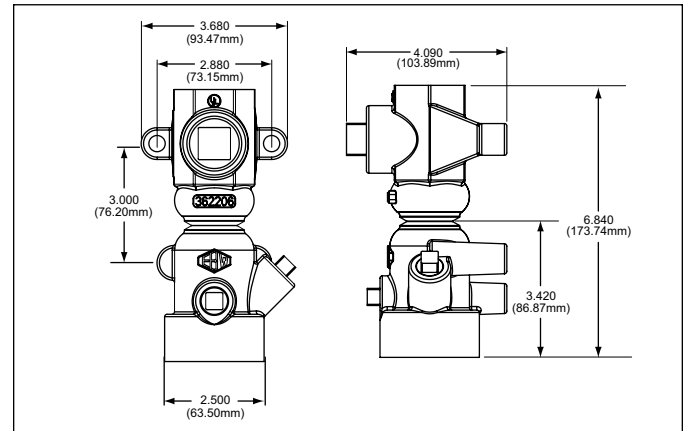
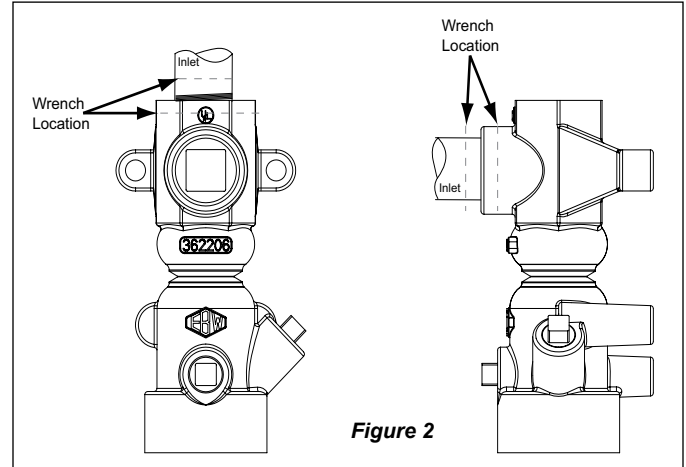
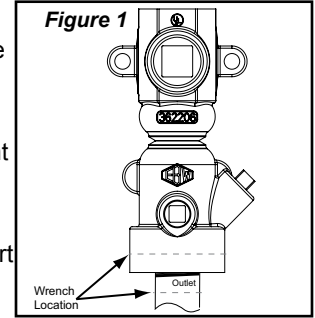

Figure 3: Shear Valve Dimensions

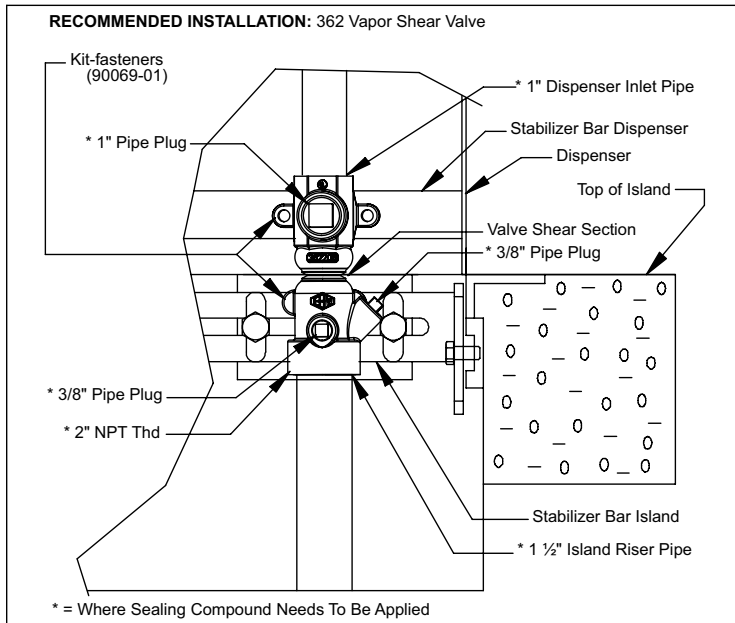

Figure 4: Shear Valve Installation



Franklin Fueling Systems

3760 Marsh Road
 Madison, WI 53718, U.S.A.
 Tel: +1 608 838 8786
 Tel: USA & Canada 1 800 225 9787
 Tel: Mexico 001 800 738 7610
 www.franklinfueling.com